



## Surftest

## Formtracer

## Contracer

## Roundtest

SV-C3200 / SV-C4500

CV-2100

SJ-410

## INDEX

<b>Surftest</b>	
Surftest SJ-210	J-2
Surftest SJ-310	J-3
Surftest SJ-210/310 Optional Accessories	J-4,5
Surftest SJ-410	J-6,7
Surftest SJ-500/P, SV-2100	J-8,9
Surftest SV-3200	J-10,11
Surftest Extreme SV-3000CNC	J-12
Surftest Extreme SV-M3000CNC	J-13
<b>Formtracer</b>	
Formtracer SV-C3200 / SV-C4500	J-14,15
Formtracer Extreme SV-C4500CNC	J-16,17
Formtracer CS-3200	J-18,19
Formtracer Extreme CS-5000CNC / CS-H5000CNC	J-20,21
Optional Stylis for Surface Roughness Measurement	J-22,23
Optional Accessories for Automatic Measurement	J-24
Optional Accessories for Surftest / Formtracer	J-25
Quick Guide to Precision Measuring Instruments-Surftest	J-26,27
<b>Contracer</b>	
Contracer CV-2100	J-28,29
Contracer CV-3200 / CV-4500	J-30,31
Optional Arms and Stylis for Contour Measurement	J-32-34
Optional Accessories for Automatic Measurement	J-35
Optional Accessories for Contracer / Formtracer	J-36
Quick Guide to Precision Measuring Instruments-Contracer	J-37,38
<b>Roundtest</b>	
Roundtest RA-120 / 120P	J-39,40
Roundtest RA-1600 / RA-1600M	J-41,42
Roundtest RA-2200AS / DS / AH / DH	J-43,44
Roundtest RA-H5200AS / AH	J-45,46
Roundtest Extreme RA-2200CNC / RA-H5200CNC	J-47,48
Optional Stylis for Roundtest	J-49,50
Optional Accessories for Roundtest	J-51
Eco-Fix Kit Form-S & L	J-52
Quick Guide to Precision Measuring Instruments-Roundtest	J-53,54



# Surftest SJ-210/SJ-310

## SERIES 178 — Portable Surface Roughness Tester



Surftest SJ-210



### FEATURES

- The 2.4-inch color graphic LCD provides excellent readability and an intuitive display that is easy to use. The LCD also includes a backlight for improved visibility in dark environments.
- The Surftest SJ-210 can be easily operated using the buttons on the front of the unit and under the sliding cover.
- Up to 10 measurement conditions and one measured profile can be stored in the internal memory.
- An optional memory card can be used as an extended memory to store large quantities of measured profiles and conditions.

- Access to each feature can be password-protected, which prevents unintended operations and allows you to protect your settings.
- The display interface supports 16 languages, which can be freely switched.
- An alarm warns you when the cumulative measurement distance exceeds a preset limit.
- The Surftest SJ-210 complies with the following standards: JIS (JIS-B0601-2001, JIS-B0601-1994, JIS B0601-1982), VDA, ISO-1997, and ANSI.
- In addition to calculation results, the Surftest SJ-210 can display sectional calculation results and assessed profiles, load curves, and amplitude distribution curves.

### SPECIFICATIONS/CONFIGURATION

Model No.	SJ-210					
Order No. (inch/mm)	178-561-01A	178-561-02A	178-563-01A	178-563-02A	178-565-01A	178-565-02A
Drive unit	Standard type (178-230-2)		Retractable type (178-235)		Transverse tracing type (178-233-2)	
Detector	0.75mN type (178-296)	4mN type (178-390)	0.75mN type (178-296)	4mN type (178-390)	0.75mN type (178-387)	4mN type (178-386)
Display unit	Compact type (178-253A)					
Detector: Tip angle	60°	90°	60°	90°	60°	90°
Stylus tip radius	2µm	5µm	2µm	5µm	2µm	5µm
Detector measuring force	0.75mN	4mN	0.75mN	4mN	0.75mN	4mN
Standard accessories	<b>12BAA303</b> Connecting cable <b>178-602</b> Roughness specimen (Ra 3.00µm) <b>12BAK699</b> Carrying case <b>12BAK700</b> Calibration stage <b>12BAK820</b> Protective sheets for display AC Adapter Operation manual Quick reference manual Warranty			<b>12BAA303</b> Connecting cable <b>178-606</b> Roughness specimen (Ra 1.00µm) <b>12AAE643</b> Point-contact adapter <b>12AAE644</b> V-type adapter <b>12BAK699</b> Carrying case <b>12BAK700</b> Calibration stage <b>12BAK820</b> Protective sheets for display AC Adapter, Operation manual Quick reference manual, Warranty		

### DIMENSIONS Display unit, Drive unit

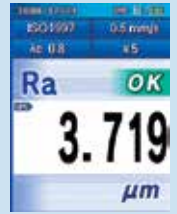
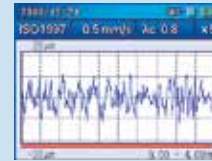
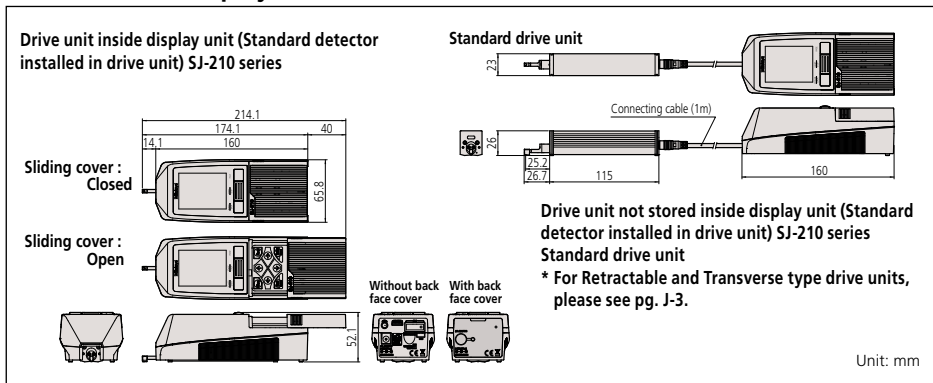

### Technical Data: SJ-210

X axis (drive unit)	Measuring range: .70" (17.5mm)
	.22" (5.6mm) Transverse type
Measuring speed:	.01, .02, .03"/s (0.25, 0.5, 0.75mm/s)
	.039"/s (1mm/s) (Returning)
Detector:	Range / Resolution: Auto / depending on the measurement range
	14400 µin / .8 in (360 µm / 0.02 µm)
	4000 µin / .2 µin (100 µm / 0.006 µm)
	1000 µin / .08 µin (25 µm / 0.002 µm)
Measuring method:	skidded
Measuring force:	4mN (0.75mN)
Stylus tip:	Diamond, 90° / 5µmR (60° / 2µmR)
Skid radius of curvature:	40mm
Skid force:	less than 400mN
Type:	Differential inductance
Power supply:	Two-way power supply: battery (rechargeable Ni-MH battery) and AC adapter
Charging time:	about 4 hours (may vary due to ambient temperature)
Endurance:	about 1000 measurements (differs slightly due to use conditions/environment)
External I/O:	USB I/F, Digimatic Output, Printer Output, RS-232C I/F, Foot SW I/F
Data storage:	Micro SD card w/ adapter (4GB) (option <b>12AAL069</b> )
Dimensions (WxDxH)	Display unit: 2.05x2.59x6.3" (52.1 x 65.8 x 160mm)
	Drive Unit: 4.5x.9x1" (115 x 23 x 26mm)
Mass:	About 1.1lb (0.5kg) (Display unit + Drive unit + Standard detector)

### Evaluation Capability: SJ-210

Applicable standards: JIS'82, JIS'94, JIS'01, ISO'97, ANSI, VDA

Assessed profiles: Primary profile, Roughness profile, DF profile, Roughness profile-Motif

Evaluation parameters: Ra, Rc, Ry, Rz, Rq, Rt, Rmax, Rp, Rv, R3z, Rsk, Rku, Rc, RPC, Rsm, Rz1max, S, HSC, RzJIS, Rppi, RΔa, RΔq, Rlr, Rmr, Rm(c), R&c, Rk, Rpk, Rvk, Mr1, Mr2, A1, A2, Vo, Rpm, tp, Htp, R, Rx, AR, Possible Customize

Analysis graphs: Bearing area curve / Amplitude distribution curve

Digital filters: Gaussian, 2CR75, PC75

Cut off length: λc: .003, .01, .03, .1" (0.08, 0.25, 0.8, 2.5mm)  
λs: .1, .3" (2.5, 8µm)

Sampling length: .003, .01, .03, .1" or arbitrary (0.08, 0.25, 0.8, 2.5mm) or arbitrary

Number of sampling lengths (x n): x1, x2, x3, x4, x5, x6, x7, x8, x9, x10 arbitrary length (0.3 to 16.0mm: 0.01mm interval)  
x1, x2, x3, x4, x5, x6, x7, x8, x9, x10 arbitrary length (0.3 to 5.6mm: 0.01mm interval)\*

\* Only for Transverse tracing drive unit type

### Function: SJ-210

Customization: Desired parameters can be selected for calculation and display.

Go/no-go judgment: By max value / 16% / Standard dev.

Storage of measurement condition: Save the conditions at power OFF

Storage: Internal memory: Measurement condition (10 sets), Measured profile (1set)

Memory card (Option): 500 measurement conditions, 10,000 measured profiles, 500 display images

Text file (Measurement conditions / Measured profile / Assessed profile / Bearing area curve / Amplitude distribution curve)

Calibration: Auto-calibration with the entry of numerical value / Average calibration with multiple measurement (Max.5 times) is available

## Technical Data: SJ-310

X axis (drive unit)	
Measuring range:	.70" (17.5mm) .22" (5.6mm) Transverse type
Measuring speed:	.01, .02, .03"/s (0.25, 0.5, 0.75mm/s) .039"/s (1mm/s) Returning
Detector:	
Range / Resolution:	Auto / depending on the measurement range 14400 $\mu$ in / .8 in (360 $\mu$ m / 0.02 $\mu$ m) 4000 $\mu$ in / .2 $\mu$ in (100 $\mu$ m / 0.006 $\mu$ m) 1000 $\mu$ in / .08 $\mu$ in (25 $\mu$ m / 0.002 $\mu$ m)
Measuring method:	skidded
Measuring force:	4mN (0.75mN)
Stylus tip:	Diamond, 90° / 5 $\mu$ mR (60° / 2 $\mu$ mR)
Skid radius of curvature:	40mm
Skid force:	less than 400mN
Type:	Differential inductance
Power supply:	Two-way power supply: battery (rechargeable Ni-MH battery) and AC adapter
Battery	
Charging time:	4 hours maximum
Recharge cycles:	Approximately 1500 times (slightly varies with the usage and environmental conditions)
External I/O:	USB I/F, Digimatic Output, RS-232C I/F, External SW I/F
Data storage:	Micro SD card w/ adapter (4GB) (option <b>12AAA841</b> )
Dimensions (WxDxH)	
Control unit:	10.8x4.29x7.8" (275 x 109 x 198mm)
Drive unit:	4.5x.9x1" (115 x 23 x 26mm)
Mass	
Display unit:	Approx. 3.7lb (1.7kg)
Drive unit:	.4lb (0.2kg)

## Evaluation Capability: SJ-310

Applicable standards:	
JIS'82, JIS'94, JIS'01, ISO'97, ANSI, VDA	
Assessed profiles:	
P (primary profile), R (roughness profile), DIN4776, roughness motif, waviness motif	
Evaluation parameters:	
Ra, Ry, Rz, Rt, Rp, Rq, Rv, Rsk, Rku, Rc, RSm, S, R <sub>Pc</sub> , R <sub>3z</sub> , R <sub>m</sub> (c), R <sub>pk</sub> , R <sub>vk</sub> , R <sub>d</sub> c, R <sub>k</sub> , Mr1, Mr2, Lo, R <sub>ppi</sub> , R, AR, R <sub>x</sub> , A1, A2, Vo, HSC, R <sub>mr</sub> , SK, Ku, R <sub>Δa</sub> , R <sub>Δq</sub> , R <sub>lr</sub> , λ <sub>a</sub> , λ <sub>q</sub> , R <sub>pm</sub> , RzJIS (JIS'01), tp (ANSI), Htp (ANSI), Wte, W <sub>x</sub> , W, AW, Rz1max (ISO), R <sub>max</sub> (VDA, ANSI, JIS'82), Possible Customize	
Analysis graphs:	
Bearing Area Curve (BAC), Amplitude Distribution Curve (ADC)	
Digital filter:	2CR, PC75, Gaussian
Cutoff length:	λ <sub>c</sub> : .003, .01, .03, .1, .3" (0.08, 0.25, 0.8, 2.5, 8mm) λ <sub>s</sub> : .1, .3" (2.5, 8 $\mu$ m)
Sampling length:	.003, .01, .03, .1, .3" or arbitrary (0.08, 0.25, 0.8, 2.5, 8mm) or arbitrary
Number of sampling lengths (x n):	
x1, x2, x3, x4, x5, x6, x7, x8, x9, x10 arbitrary length (0.3 to 16.0mm: 0.01mm interval)	
x1, x2, x3, x4, x5, x6, x7, x8, x9, x10 arbitrary length (0.3 to 5.6mm: 0.01mm interval)*	
* Only for Transverse tracing drive unit type	
Printer:	Thermal type
Printing width:	48mm (paper width: 58mm)
Recording magnification:	
Vertical magnification: 10X to 100,000X, Auto	
Horizontal magnification: 1X to 1,000X, Auto	

## Function: SJ-310

Customization: Desired parameters can be selected for calculation and display.	
Statistical processing: Maximum value, minimum value, mean value, standard deviation, pass rate, histogram of each parameter	
Go/no-go judgment: maximum value rule, 16% rule, average value rule, standard deviation (1 $\sigma$ , 2 $\sigma$ , 3 $\sigma$ )	
Storage: Internal memory: Measurement condition (10 sets)	
Memory card (Option): 500 measurement conditions, 10,000 measured profiles, 500 display images, Text file (Measurement conditions / Measured profile / Assessed profile / Bearing area curve / Amplitude distribution curve), 500 statistical data, etc.	
Calibration: Auto-calibration with the entry of numerical value / Average calibration with multiple measurement (Max.12 times) is available.	
Power-saving function: Auto-sleep-function, Auto light-off of Backlight by ECO mode.	

# Surftest SJ-210/SJ-310

## SERIES 178 — Portable Surface Roughness Tester



Surftest SJ-310

## FEATURES

- The data processing unit offers large 5.7-inch color graphic LCD touch-panel for superior readability and operability. The LCD also includes a backlight for improved visibility in dark environments.
- The excellent user interface provides intuitive and easy-to-understand operability.

- Complies with the following standards: JIS (JIS-B0601-2001, JIS-B0601-1994, JIS B0601-1982), VDA, ISO- 1997, and ANSI.
- The Measure-Start and other frequently used buttons are strengthened to resist wear and the detrimental effects of workshop contaminants.
- Equipped with a large-capacity battery allowing approximately 1500 measurements when fully charged.
- Includes convenient carrying case for protection in the field.
- A high-speed printer is built into the main unit. Either landscape or portfolio mode can be selected according to the application. Paper saving mode is supported.
- The display interface supports 16 languages, which can be easily switched.
- 10 sets of measurement conditions can be saved in the measurement unit—an optional memory card can save measurement conditions and the measured profile.

## SPECIFICATIONS/CONFIGURATION

Model No.	SJ-310					
Order No. (inch/mm)	178-571-01A	178-571-02A	178-573-01A	178-573-02A	178-575-01A	178-575-02A
Drive unit	Standard type (178-230-2)		Retractable type (178-235)		Transverse tracing type (178-233-2)	
Detector	0.75mN type (178-296)	4mN type (178-390)	0.75mN type (178-296)	4mN type (178-390)	0.75mN type (178-387)	4mN type (178-386)
Display unit	Standard type with printer					
Detector: Tip angle	60°	90°	60°	90°	60°	90°
Stylus tip radius	2 $\mu$ m	5 $\mu$ m	2 $\mu$ m	5 $\mu$ m	2 $\mu$ m	5 $\mu$ m
Detector measuring force	0.75mN	4mN	0.75mN	4mN	0.75mN	4mN
Standard accessories	<b>12AAM475</b> Connecting cable <b>12AAA217</b> Nosepiece for plane surface <b>12AAA218</b> Nosepiece for cylinder <b>12AAA216</b> Supporting leg <b>12BAK700</b> Calibration stage <b>12BAG834</b> Stylus pen <b>12BAL402</b> Protection sheet <b>270732</b> Printer paper (5 pieces) <b>12BAL400</b> Carrying case <b>178-602</b> Roughness reference specimen (Ra 3 $\mu$ m), AC adapter, Philips screwdriver, Strap for stylus pen, Operation manual, Quick reference manual, Warranty				<b>12AAM475</b> Connecting cable <b>12AAE643</b> Point-contact adapter <b>12AAE644</b> V-type adapter <b>12BAK700</b> Calibration stage <b>12BAG834</b> Stylus pen <b>12BAL402</b> Protection sheet <b>270732</b> Printer paper (5 pieces) <b>12BAL400</b> Carrying case <b>178-606</b> Roughness reference specimen (Ra 1 $\mu$ m), AC adapter, Philips screwdriver, Strap for stylus pen, Operation manual, Quick reference manual, Warranty	

## DIMENSIONS Display unit, Drive unit

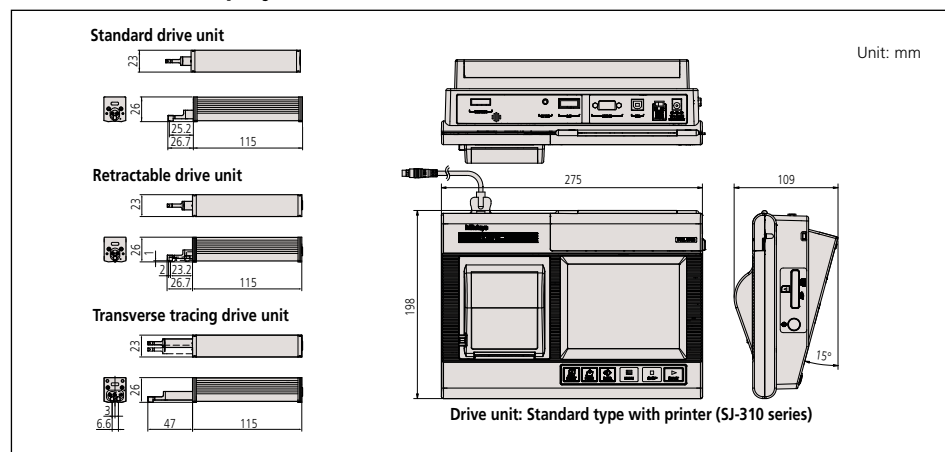

# Surftest SJ-210 / SJ-310

## SERIES 178 — Optional Accessories

### Detectors

#### Standard detectors

Order No.	Measuring force	Stylus profiles*	Remarks column
178-296	0.75mN	2 $\mu$ mR/60°	Dedicated to the standard/retractable drive unit
178-390	4 mN	5 $\mu$ mR/90°	
178-387	0.75mN	2 $\mu$ mR/60°	Dedicated to the transverse tracing drive unit
178-386	4 mN	5 $\mu$ mR/90°	
178-395	0.75mN	2 $\mu$ mR/90°	Dedicated to the standard/retractable drive unit
178-391	4 mN	10 $\mu$ mR/90°	

\* Tip radius / Tip angles

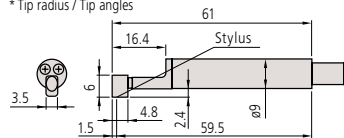

#### Small hole detectors

Order No.	Measuring force	Stylus profiles*	Remarks column
178-383	0.75mN	2 $\mu$ mR/60°	Minimum measurable hole diameter: $\phi$ 4.5mm
178-392	4 mN	5 $\mu$ mR/90°	

\* Tip radius / Tip angles

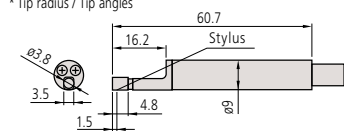

#### Extra small hole detectors

Order No.	Measuring force	Stylus profiles*	Remarks column
178-384	0.75mN	2 $\mu$ mR/60°	Minimum measurable hole diameter: $\phi$ 2.8mm
178-393	4 mN	5 $\mu$ mR/90°	

\* Tip radius / Tip angles

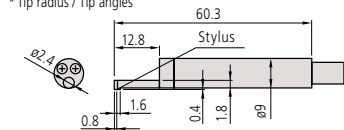

Unit: mm

#### Gear-tooth surface detectors

Order No.	Measuring force	Stylus profiles*
178-388	0.75mN	2 $\mu$ mR/60°
178-398	4 mN	5 $\mu$ mR/60°

\* Tip radius / Tip angles

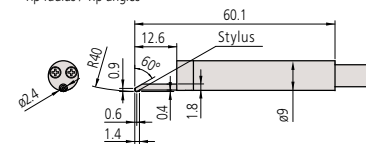

#### Deep groove detectors

Order No.	Measuring force	Stylus profiles*	Remarks column
178-385	0.75mN	2 $\mu$ mR/60°	Not available for the transverse tracing drive unit
178-394	4 mN	5 $\mu$ mR/90°	

\* Tip radius / Tip angles

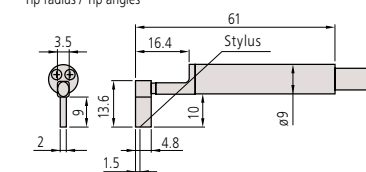

### SJ-Printer for SJ-210

Assessed profiles and calculation results and curves can be printed out by connecting the SJ-210-dedicated printer, which is palm sized (WxDxH: 93x125x70mm) and can run on an internal battery.

- Power supply can be selected. (AC adapter or battery pack)
- Printable items: Measurement conditions, calculation results, assessed profile, bearing area curve (BAC), amplitude distribution curve (ADC), and environment settings.



178-421A

\*Not compatible with older SJ-201 models.



Example of the connection with SJ-210

Durable Printer paper (25m, 5 rolls/set): **12AAA876**

Printer paper (5 packs): **270732**

RS-232C cable: **12AAL067**

### DP-1VA

It is possible to process Digimatic data output from the Surftest SJ series with the DP-1VA. This compact, hand-held device can provide printouts of measurement data and various statistical analyses results such as histograms, D-charts, and Xbar-R control charts. With optional output cables, DP-1VA is also capable of RS-232C output of measurement data to a PC (cable **09EAA084**) and go/no-go condition output (cable **965516**).



264-505A

Connecting cable: **936937** 40'' (1m)

Connecting cable: **965014** 80'' (2m)

AC adapter: **06AEG180JA**

Printer paper: **09EAA082**



## Free Communication Software

### SJ-Tools

This program can be downloaded for FREE from the Mitutoyo website. <http://www.mitutoyo.com>

Output software based on Microsoft-Excel\* for controlling the devices and reproducing and storing the measurement data.

\* Microsoft-Excel is not included in the scope of supply. Complete with exclusive accessories.

- Measurement device control
- Definition of measurement variables
- Graphic representation of the profile
- Storage of measurement records
- Documentation of measurement results
- Connecting cable

Optional cables (Required for software communication)

**12AAL068:** USB PC connecting cable(USB cable) for SJ-210

**12AAD510:** USB PC connecting cable(USB cable) for SJ-310/410

**12AAL067:** RS-232C cable for SJ-210

**12AAA882:** RS-232C cable for SJ-310/410

**12AAH490:** USB PC connecting cable for SJ-500/SV-2100

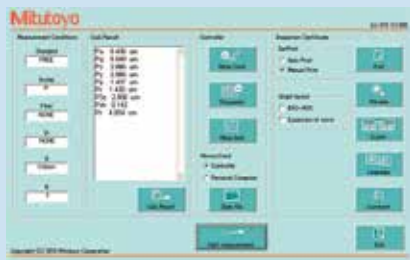

SJ-Tools input mask for Surftest SJ series

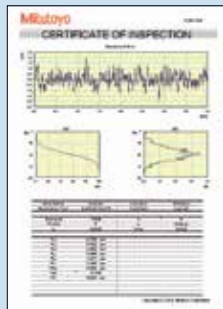

SJ-Tools output record from MS-Excel

Required environment\*:

- OS:  
Windows XP-SP3  
Windows Vista  
Windows 7/8/10
- Spreadsheet software:  
Microsoft Excel 2000/2002/  
2003/2007/2010/2013/2016

\* Windows OS and Microsoft Excel are products of Microsoft Corporation.

## Optional Accessories

**12AAL272:** SJ-210 Replacement Battery Pack

**12AAN046:** SJ-310 Replacement Battery Pack

**12BAK820:** SJ-210 Display Protection Sheet (1pc.)

**12AAL066:** SJ-210 Display Protection Sheet (5pcs.)

**12BAL402:** SJ-310 Display Protection Sheet (1pc.)

**12AAN040:** SJ-310 Display Protection Sheet (10pcs.)

**178-601:** Precision Reference Specimen (Ra 3.00 μm)

**178-602:** Precision Reference Specimen  
(Ra 119 μm / 3.00 μm)

**178-603:** Precision Reference Specimen – 2 values (GAR)

**178-604:** Precision Reference Specimen – 2 Values (MIT)

**178-606:** Precision Reference Specimen for Transverse Drive  
(Ra 39.5 μm / 1.0 μm)

**178-029:** Manual Column Stand, must use adapter  
12AAA221 to mount SJ drive unit.

## Nosepiece, Adapter

### Nosepiece for flat surfaces

**12AAA217**

- SJ-210/210R optional accessory.
- SJ-310/310R standard accessory.
- Not available for the transverse tracing drive unit.

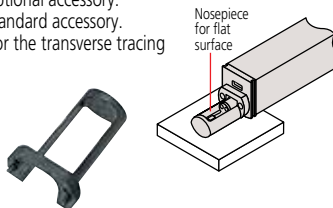

### V-type adapter

**12AAE644**

- SJ-210/SJ-310 Transverse tracing type standard accessory.
- Dedicated to the transverse tracing drive unit.

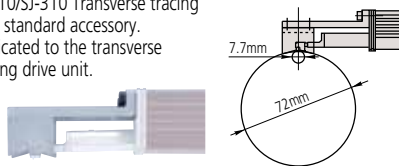

### Extension rod (50mm)

**12AAA210**

- Not available for the transverse tracing drive unit.

(Note: Only one rod can be used.)

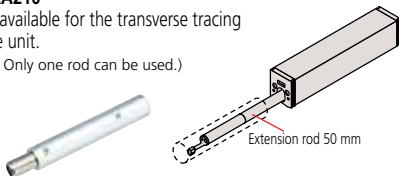

### Magnetic stand adapter

**12AAA221 (ø8mm)**

**12AAA220 (ø9.5mm)**

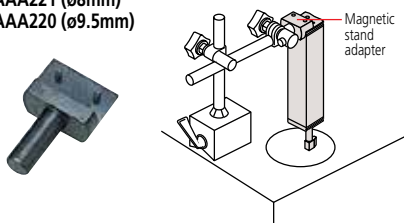

### Extension cable (1m)

**12BAA303**

- Only one cable can be used.

## Setting attachments

\* Not available for the transverse tracing drive unit

Improves measurement efficiency by allowing the setup of workpieces of the same type and the positioning of hard-to-access features of a workpiece.

**No. 178-033**

V-type for measuring in the cylinder axis direction



The V-width is adjustable to the cylinder diameter facilitating axial measurement of a wide range of cylinder diameters.

- Adjustable range: ø 5 - 150mm

**No. 178-034**

Setting attachment: Magnetic slider type



Best suited for measurement of the flat surface of a workpiece that has partial indentations and steps and that is hard to set the drive unit. Combination use with the magnet type specimen holder (Option No. 12AA910) further improves the ease of operation.

**No. 178-035**

Setting attachment: Inside diameter type



Greatly facilitates measurement of internal wall surfaces of, for example, cylinder-block bores.

- Applicable diameter: ø75 - ø95mm
- Accessible depth: 30 - 135mm

### Nosepiece for cylindrical surfaces

**12AAA218**

- SJ-210/210R optional accessory.
- SJ-310/310R standard accessory.
- Not available for the transverse tracing drive unit.
- ø30mm or smaller workpiece

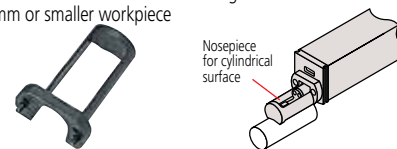

### Point-contact adapter

**12AAE643**

- SJ-210/SJ-310 Transverse tracing type standard accessory.
- Dedicated to the transverse tracing drive unit.



### Support feet set

**12AAA216**

- SJ-210/210R optional accessory.
- SJ-310/310R standard accessory.
- Not available for the detector side of the transverse tracing drive unit.

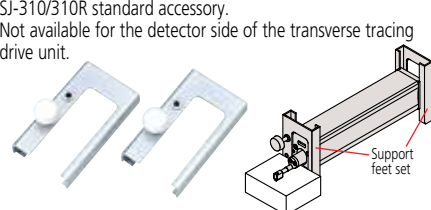

### Vertical positioning adapter

**12AAA219**

- Not available for the transverse tracing drive unit.

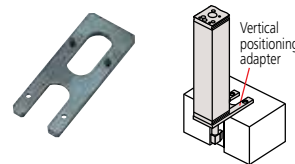

### Height gage adapter

**12AAA222 (9mm x 9mm)**

**12AAA233 (1/4" x 1/2")**

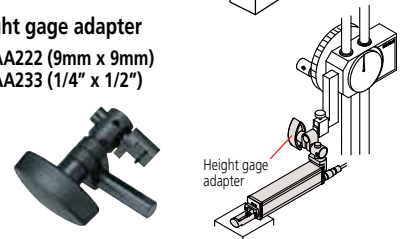

# Surftest SJ-410

## SERIES 178 — Portable Surface Roughness Tester

### FEATURES

- Both skidded and skidless measurement are possible with this series. Equipped with 46 roughness parameters that conform to the latest ISO, DIN, ANSI, and JIS standards.
- A wide-range, high-resolution detector and a drive unit provide superior high-accuracy measurement in its class.

#### Detector

Measuring range: 800µm  
Resolution: 0.000125µm (at 8µm range)

#### Drive unit

Straightness/traverse length  
SJ-411: 0.3µm/25mm  
SJ-412: 0.5µm/50mm



- A skidless detector and a curved surface compensation function provide efficient evaluation of cylinder surface roughness.

### Skidless measurement

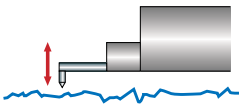

Surftest SJ-411

### SPECIFICATIONS

Model No.	SJ-411	SJ-411	SJ-412	SJ-412
<b>Order No. (inch/mm)</b>	<b>178-581-01A</b>	<b>178-581-02A</b>	<b>178-583-01A</b>	<b>178-583-02A</b>
Detector measuring force	0.75mN	4mN	0.75mN	4mN
Evaluation range	25mm	25mm	50mm	50mm
Stylus tip	Tip angle	60°	90°	60°
	Tip radius	2µm	5µm	2µm

- Ultra-fine steps, straightness and waviness can be measured by using the skidless measurement function.
- The handheld data processing unit and the 5.7-inch color graphic LCD touch-panel provides superior readability and operability. The LCD also includes a backlight for improved visibility in dark environments.
- The excellent user interface provides intuitive and easy-to-understand operability.
- Measured data can be output to a PC with optional RS-232C or USB cable.
- Digital filter function for non-distorted roughness profiles.
- Go/no-go judgment function.
- Auto-calibration function.
- The display interface supports 16 languages, which can be freely switched.
- Simplified contour analysis function supports the four types of measurement: step, level change, area and coordinate difference.
- Access to each feature can be password-protected, which prevents unintended operations and allows you to protect your settings.
- The optional attachments for mounting on a column stand significantly increase the operability.

### Technical Data: X axis (drive unit)

Measuring range:	1" (25mm) (SJ-411), 2" (50mm) (SJ-412)
Measuring speed:	.002, .004, .008, .02, .04"/s (0.05, 0.1, 0.5, 1.0mm/s)
Return speed:	.02, .04, .08"/s (0.5, 1.0, 2.0mm/s)
Traversing direction:	Backward
Traverse linearity:	12 µin / 1" (0.3µm/25mm) (SJ-411), 20 µin / 2" (0.5µm/50mm) (SJ-412)
Positioning:	±1.5° (tilting), 10mm (up/down)
Detector Range / resolution:	800µm / 0.0125µm, 80µm / 0.00125µm, 8µm / 0.000125µm (up to 2400µm with an optional stylus)
Measurement method:	Skidless / skidded
Measuring force:	0.75mN (4mN)
Stylus tip:	Diamond, 60° / 2µmR (90° / 5µmR)
Skid radius of curvature:	40mm
Type:	Differential inductance
Power supply:	Via AC adapter / rechargeable battery
Battery life:	Max. app. 1000 measurements (w/o printing)
Recharge time:	4 hours Data output Via USB interface / RS-232C interface / SPC output
Storage: Internal memory:	Measurement condition (10 sets)
Memory card (Option):	500 measurement conditions, 10,000 measured profiles, 500 display images, Text file (Measurement conditions / Measured profile / Assessed profile / Bearing area curve / Amplitude distribution curve), 500 statistical data, etc.
Dimensions (WxDxH)	
Display unit:	10.8x4.3x7.8" (275x109 x198mm)
Height-tilt adjustment unit:	5.16x2.48x3.9" (131x63x99mm)
Drive unit:	5.04x1.41x1.83" (128x36x47mm) (SJ-411), 6.1x1.41x1.83" (155x36x47mm) (SJ-412)
Mass Control unit:	Approx. 3.75lb (1.7kg)
Height-tilt adjustment unit:	Approx. .9lb (0.4kg)
Drive unit:	1.3lb(0.6kg) (SJ-411), 1.5lb(0.7kg)(SJ-412)

### Evaluation Capability

Applicable standards:	JIS'82, JIS'94, JIS'01, ISO'97, ANSI, VDA, Free
Assessed profiles:	P (primary profile), R (roughness profile), DF (DF profile), W (filtered waviness profile), roughness motif, waviness motif
Evaluation parameters:	Ra, Rq, Rz, Ry, Rp, Rv, Rt, R3z, Rsk, Rku, Rc, Rpc, RSm, Rmax(VDA, ANSI), Rz1max(ISO'97), S, HSC, RzJIS(JIS'01), Rppi, RΔa, RΔq, Rlr, Rmr, Rmr(c), Rδc, Rk, Rpk, Rvk, Mr1, Mr2, A1, A2, Vo, λq, Lo, Rpm, tp(ANSI), Htp(ANSI), R, Rx, AR, W, AW, Wx, Wte
Analysis graphs:	Bearing Area Curve (BAC), Amplitude Distribution Curve (ADC)
Digital filter:	2CR, PC75, Gaussian
Cutoff length:	λc: .003, .01, .03, .1, .3" (0.08, 0.25, 0.8, 2.5, 8mm) λs: 100, 320, 1000µin (2.5, 8, 25µm) (Availability of switching depends of the selected standard.)
Sampling length:	0.08, 0.25, 0.8, 2.5, 8, 25*mm; or arbitrary length in range 0.1 to 25mm (0.1 to 50mm: SJ-412) in 0.01mm increments
Number of sampling lengths:	1, 2, 3, ~20 (limited by traverse range)
Printer:	Thermal type
Printing width:	48mm (paper width: 58mm)
Recording magnification	
Vertical magnification:	10X to 100,000X, Auto
Horizontal magnification:	1X to 1,000X, Auto
Function	
Customize:	Selection of display/evaluation parameter
Data compensation:	R-surface, Tilt compensation
Ruler function:	Step, level change, area and coordinate difference
D.A.T. function:	Helps to level workpiece prior to skidless measurement displacement detection mode enables the stylus displacement to be input while the drive unit is stopped.
Statistical processing:	Max. value, Min. value, Mean value, Standard deviation (s), Pass ratio, Histogram
GO/NG judgement:	Maximum value rule, 16% rule, average value rule, standard deviation (1σ, 2σ, 3σ)
Calibration:	Auto-calibration with the entry of numerical value /average calibration with multiple measurement (Max.12 times) is available.
Power saving function:	Auto-sleep-function, Auto light-off of Backlight by ECO mode.

\* Only for SJ-412

# Surftest SJ-410

## SERIES 178 — Portable Surface Roughness Tester

### DIMENSIONS

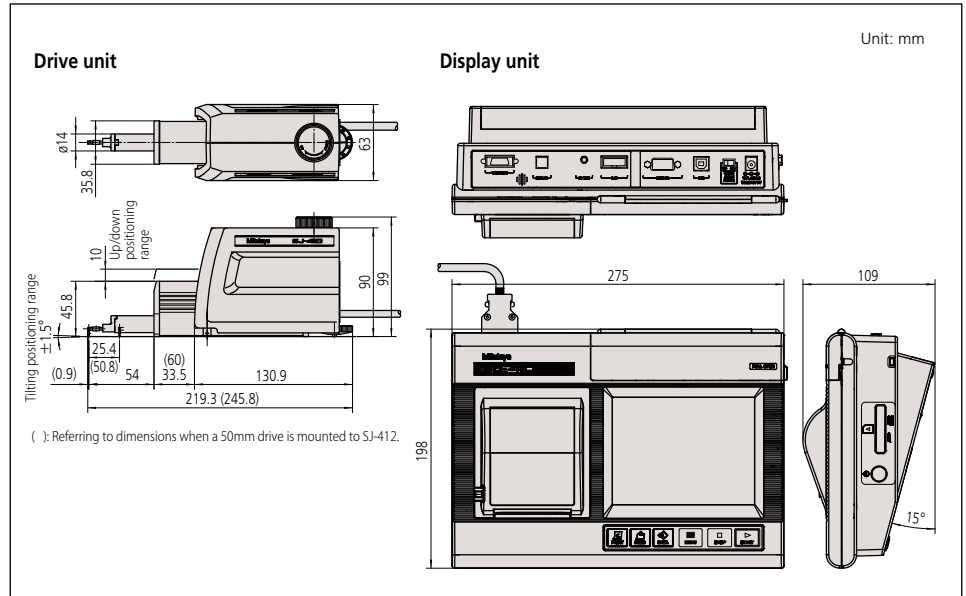

### Free Communication Software SJ-Tools

This program can be downloaded for FREE from the Mitutoyo website. <http://www.mitutoyo.com>

Output software based on Microsoft-Excel\* for controlling the devices and reproducing and storing the measurement data.

\*Microsoft-Excel is not included in the scope of supply.

Complete with exclusive accessories.

- Measurement device control
- Definition of measurement variables
- Graphic representation of the profile
- Storage of measurement results
- Documentation of measurement results

Optional cables (Required for software communication)

- 12AAD510:** USB PC connecting cable (USB cable)
- 12AAA882:** RS-232C connecting cable

### Optional Accessories

- 178-611:** Step gage (2 $\mu$ m, 10 $\mu$ m)
- 178-612:** Step gage (2 $\mu$ m, 10 $\mu$ m, 79 $\mu$ m, 394 $\mu$ m)
- 178-610:** Step gage (step: 1 $\mu$ m, 2 $\mu$ m, 5 $\mu$ m, 10 $\mu$ m)
- 12AAM556:** Height/tilt adjustment unit for SJ-410
- 178-039:** Manual column stand (granite base) (vertical travel: 250mm)
- 178-010:** Auto-set unit for **178-039**
- 178-020:** X axis adjustment unit for **178-039**
- 178-030:** Tilting adjustment unit (Inclination adjustment unit) for **178-039**
- 12AAB358:** Cylindrical surface adapter (workpiece dia.: 15 - 60mm)
- 178-016:** Leveling table (tilting:  $\pm 1.5^\circ$ , max. loading: 15kg)
- 178-048:** Leveling table with D.A.T function (mm) (tilting:  $\pm 1.5^\circ$ , max. loading: 15kg)
- 178-058:** Leveling table with D.A.T function (inch) (tilting:  $\pm 1.5^\circ$ , max. loading: 15kg)
- 178-043-1:** XY leveling table (25 x 25mm) (tilting:  $\pm 1.5^\circ$ , max. loading: 15kg, swiveling:  $\pm 3^\circ$ )
- 178-053-1:** XY leveling table (1" x 1") (tilting:  $\pm 1.5^\circ$ , max. loading: 15kg, swiveling:  $\pm 3^\circ$ )
- 178-042-1:** Digital XY leveling table (25 x 25mm) (tilting:  $\pm 1.5^\circ$ , max. loading: 15kg, swiveling:  $\pm 3^\circ$ )
- 178-052-1:** Digital XY leveling table (1" x 1") (tilting:  $\pm 1.5^\circ$ , max. loading: 15kg, swiveling:  $\pm 3^\circ$ )
- 178-049:** Digital XY leveling table (25 x 25mm) (max. loading: 15kg)
- 178-059:** Digimatic XY leveling table (1" x 1") (max. loading: 15kg)
- 178-019:** Precision vise for XY leveling table (jaw opening: 36mm)
- 998291:** Precision V-block for XY leveling table (workpiece dia.: 1 - 160mm)
- 12AAL069:** Micro SD card w/adaptor (4GB)
- 965014:** SPC cable (2m)
- 264-012-10:** Input tool (USB type)
- 264-505A:** DP-1VA
- : Detectors, Styli, and nosepieces (See pg. J-22/23.)

### Consumables

- 12AAN040:** LCD protective sheet (10 sheets/set)
- 12AAA876:** Durable printer paper (25m, 5 rolls/set)
- 270732:** Printer paper (5 pack)
- 12AAN046:** Replacement battery
- 12AAJ088:** Footswitch

### MEASUREMENT APPLICATIONS

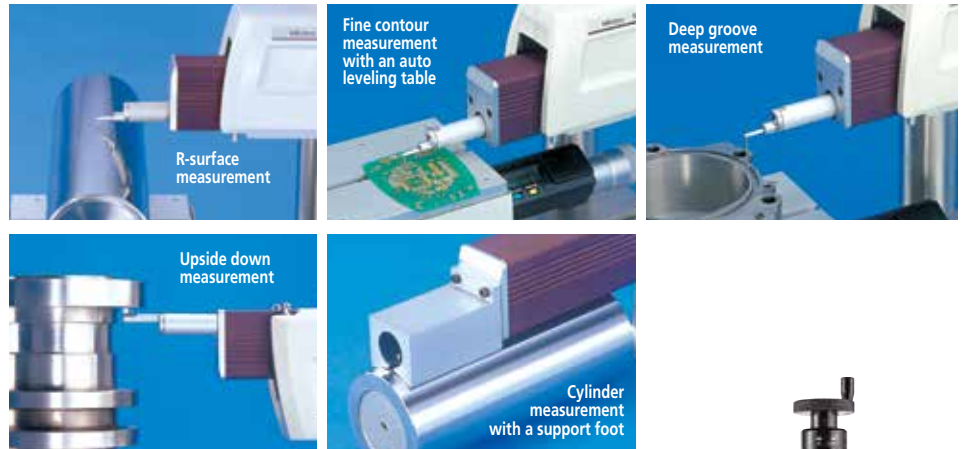

Carrying case is a standard accessory.



With optional accessories.

- 178-010:** Auto-set unit
- 178-020:** X-axis adjustment unit
- 178-030:** Tilting adjustment unit

# Surftest SJ-500/P, SV-2100

## SERIES 178 — with Dedicated Control / PC System / Display Unit

High-precision and high-performance surface roughness tester with a dedicated control unit, achieving user-friendly display and simple operation.

### FEATURES

- User-friendly display and simple operation equipped with a highly visible color 7.5-inch TFT LCD.
- Easy positioning. A joy stick built in the dedicated control unit allows easy and quick positioning. Fine positioning of a small stylus, required for measuring the inner side of a small hole, easily can be made using the manual knob.
- Easy setting of measuring conditions for surface roughness. Equipped with simple input function allows inputs according to drawing instruction symbols of ISO/JIS roughness standards. Troublesome measuring condition settings can be easily input by directly selecting a drawing instruction symbol for surface roughness from the menu.



SJ-500



SV-2100S4



SJ-500P

### SURFPAK-EZ: Easy-to-use task-focused software

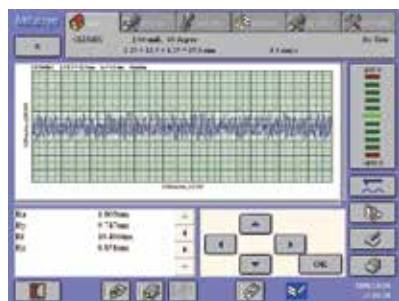

Measurement and results display screen

User-friendly graphical display and button layout allows intuitive operation. Simplified fine-contour analysis provided as standard, including step, area, angle, and circle calculation.

### Technical Data: SJ-500

X-axis (drive unit)	
Measuring range:	1.97" (50mm)
Resolution:	1.97µin (0.05µm)
Measurement method:	Linear encoder
Drive speed:	0 - .78"/s (0 - 20mm/s)
Measuring speed:	.00078 - .2"/s (0.02 - 5mm/s)
Traversing direction:	Backward
Traverse linearity:	7.8µin/1.97" (0.2µm / 50mm)
Positioning:	±1.5° (tilting, with DAT function) 1.18" (30mm) (up/down)
Detector	
Resolution / Range:	.4µin/32000µin, .04µin/3200µin, .004µin/320µin 0.01µm (800µm), 0.001µm (80µm), 0.0001µm (8µm)
Detecting method:	Skidless / skid measurement
Measuring force:	4mN (0.75mN) (low force type)
Stylus tip:	Diamond, 90° / 5µmR (60° / 2µmR: low force type)
Skid radius of curvature:	1.57" (40mm)
Detecting method:	Differential inductance
Control unit	
Display:	7.5" color TFT with backlight
Printer:	Built-in thermal printer
Magnification:	Horizontal: X10 to X500,000, Auto Vertical: X0.5 to X10,000, Auto
Drive unit control:	Joystick operation with manual knob

### Technical Data: SV-2100

X-axis (drive unit)	
Measuring range:	3.94" (100mm)
Resolution:	1.97µin (0.05µm)
Measurement method:	Linear encoder
Drive speed:	0 - 1.57"/s (0 - 40mm/s)
Measuring speed:	.00078 - .197"/s (0.02 - 5mm/s)
Traversing direction:	Pull
Traverse linearity:	6µin/4" (0.15µm / 100mm)
Z2-axis (column)	
Type:	Manual operation or power drive
Vertical travel:	13.8" or 21.6" (350mm or 550mm*)
Resolution*:	1µm
Measurement method*:	Rotary encoder
Drive speed*:	0 - .78"/s (0 - 20mm/s)
*Only for power-drive type	
Detector	
Resolution / Range :	.4µin/32000µin, .04µin/3200µin, .004µin/320µin 0.01µm / 800µm, 0.001µm / 80µm, 0.0001µm / 8µm
Detecting method:	Skidless / skid measurement
Measuring force:	4mN or 0.75mN (low force type)
Stylus tip:	Diamond, 90° / 5µmR (60° / 2µmR: low force type)
Skid radius of curvature:	1.57" (40mm)
Detecting method:	Differential inductance
Control unit	
Display:	7.5" color TFT with backlight
Printer:	Built-in thermal printer
Magnification:	Horizontal: X10 to X500,000, Auto Vertical: X0.5 to X10,000, Auto
Drive unit control:	Joystick operation with manual knob

### Evaluation Capability

Cutoff length	
Is:	0.25µm, 0.8µm, 2.5µm, 8µm, 25µm, 250µm, no filter
Ic*:	0.025mm, 0.08mm, 0.25mm, 0.8mm, 2.5mm, 8mm, 25mm
If:	0.08mm, 0.25mm, 0.8mm, 2.5mm, 8mm, 25mm, no filter
Sampling length (L)*	
	0.025mm, 0.08mm, 0.25mm, 0.8mm, 2.5mm, 8mm, 25mm, 80mm (SV-2100 only)
Data compensation functions	
	Parabola compensation, hyperbola compensation, ellipse compensation, R-plane (curved surface) compensation, conic compensation, tilt compensation

\*Arbitrary length can be specified in the range from 0.02mm to 50mm.

**12AAA876:** High durable printer paper (5 Rolls/set)

**270732:** Standard type printer paper (5pcs.)

**12AAA841:** Compact Flash memory card (128 MB)



# Surftest SJ-500/P, SV-2100

SERIES 178 — with Dedicated Control / PC System / Display Unit

## SPECIFICATIONS

Model no.	SJ-500P	SJ-500	SV-2100M4	SV-2100S4	SV-2100H4	SV-2100W4
Type of Data processing	PC System	Dedicated Data Processor	Dedicated Data Processor			
Order No. (inch)	178-531-02A	178-533-02A	178-637-01A	178-681-01A	178-683-01A	178-685-01A
Measuring force of detector	4mN	4mN	0.75mN			
X-axis measuring range	2" (50mm)		4" (100mm)			
Vertical travel	Optional stand		13.8" (350mm) manual column	13.8" (350mm) power column	21.6" (550mm) power column	
Granite base size (WxD)	Optional stand		23.6 x 17.7" (600 x 450mm)			39.4 x 17.7" (1000 x 450mm)
PC I/F Unit	13.7 x 10.4 x 3.4" (350 x 263 x 86mm)	NA	NA	NA	NA	NA
Dimensions (main unit, WxDxH)	16.7 x 3.7 x 6.3" (425 x 94 x 160mm)		28.2 x 17.7 x 34" (716 x 450 x 863mm)	28.2 x 17.7 x 38" (716 x 450 x 966mm)	28.2 x 17.7 x 46" (716 x 450 x 1166mm)	44 x 17.7 x 46.3" (1116 x 450 x 1176mm)
Main unit Mass	5.9 lbs. (2.7 kg)		308.6 lbs. (140 kg)	308.6 lbs. (140 kg)	330 lbs. (150 kg)	485 lbs (220 kg)
Assessed profiles	Dedicated data processor type: P (primary profile), R (roughness profile), WC, envelope residual profile, roughness motif, waviness motif PC system type: P (primary profile), R (roughness profile), WC, WCA, WE, WEA, DIN4776 profile, E (envelope residual profile), roughness motif, waviness motif					
Evaluation parameters	Dedicated data processor type: Ra, Rc, Ry, Rz, Rq, Rt, Rmax, Rp, Rv, R3z, Sm, S, Pc, mr (c), δc, mr, tp, Htp, Lo, lr, Ppi, HSC, Δa, Δq, Ku, Sk, Rpk, Rvk, Rk, Mr1, Mr2, A1, A2, Vo, λa, λq, R, AR, Rx, W, AW, Wx, Wte, (43 parameters), Customization PC system type: Pa, Pq, Psk, Pku, Pp, Pv, Pz, Pt, Pc, PSm, PΔq, Pmr (c), Pmr, Pδc, Ra, Rq, Rsk, Rku, Rp, Rv, Rz, Rt, Rc, RSm, RΔq, Rmr (c), Rmr, Rδc, Wa, Wq, Wsk, Wku, Wp, Wv, Wz, Wt, Wc, WSm, WΔq, Wmr (c), Wmr, Wδc, Rk, Rpk, Rvk, Mr1, Mr2, A1, A2, Rx, AR, R, Wx, AW, W, Wte, Ry, RyDIN, RzDIN, R3y, R3z, S, HSC, Lo, lr, Δa, λa, λq, Vo, Htp, NR, NCRX, CPM, SR, SAR, NW, SW, SAW					
Analysis graphs	Dedicated data processor type: ADC, BAC, power spectrum graph PC system type: ADC, BAC Graph, power spectrum graph, auto-correlation graph, Walsh power spectrum graph, Walsh auto-correlation graph, slope distribution graph, local peak distribution graph, parameter distribution graph					
Curved surface compensation	Dedicated data processor type: Parabolic compensation, Hyperbolic compensation, Elliptical compensation, Circular compensation Conic compensation, Inclination (Entire, Arbitrary) PC system type: Parabolic compensation, Hyperbolic compensation, Elliptical compensation, Circular compensation, Conic compensation, Inclination (Entire, Arbitrary), Polynomial compensation					
Contour analysis	Dedicated data processor type: Area, Circle, Angle, Coordinate difference, Step, Inclination PC system type (SURFPAK-EZ): Area, Circle, Angle, Coordinate difference, Step, Inclination					
Filters	Dedicated data processor type: 2CR-75%, 2CRPC-75%, Gaussian, Robust-spline PC system type: 2CR-75%, 2CR-50%, 2CRPC-75%, 2CRPC-50%, Gaussian, Robust-spline					

### Manual column stand options: 178-085 and 178-089 (for SJ-500)

Suitable for desktop use in inspection rooms and such.



**No.178-085\*** Does not include measuring unit  
Vertical adjustment range: 11.8" (300mm)  
Dimension (W x D x H): 23.6" x 17.7" x 28" (600 x 450 x 710mm)  
Weight: 242 lbs (110kg)  
**No.178-089\*** Does not include measuring unit  
Vertical adjustment range: 9.8" (250mm)  
Dimension (W x D x H): 15.7 x 9.8 x 2.4" (400 x 250 x 60mm)  
Weight: 44 lbs (20kg)

Dimensions of SJ-500 w/ manual column stand 178-085

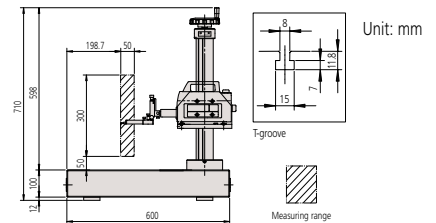

### Auto-leveling table: 178-081 (for SJ-500 / SV-2100M4), 178-083 (for SV-2100S4 / H4 / W4)



This is a stage that performs fully automatic leveling as measurement starts, freeing the user from this tedious operation. Fully automatic leveling can be done quickly by anyone. In addition, the operation is easy and reliable.

Inclination adjustment angle	±2°
Maximum load	15.4 lbs (7kg)
Table dimensions	5.12 x 3.94" (130x100mm)
Mass	7.7lbs (3.5kg)



Mitutoyo

# Surftest SV-3200

## SERIES 178 — Surface Roughness Testers



SV-3200L4 (with options)



\*Shown with optional accessories.

**MiCAT**  
Mitutoyo Intelligent Computer Aided Technology  
the standard in world metrology software  
**FORM**

The Surftest SV-3200 Series provide high-accuracy, high-level analysis and multi-functionality in measurement of surface roughness.

### FEATURES

- Mitutoyo's Surftest SV-3200 Series provides high-accuracy, high-level analysis and multi-functionality in three-dimensional analysis and measurement of fine contour, as well as the conventional type surface roughness measurement.
- Peripheral devices such as the auto-leveling table are available to enhance operability and to enable automatic measurement.
- FORMTRACEPAK V5, dedicated data-analyzing software, is installed. This software allows data management in a consistent format, from the work site to the laboratory.
- Ceramic, which is known for its superb anti-abrasive property, is used as the X-axis drive unit guide. No lubrication of the guide is required.
- High-accuracy glass scales are built-in on X-axis (resolution: 1.97 $\mu$ m (0.05 $\mu$ m) and Z2-axis (column, resolution: 39.4 $\mu$ m (1 $\mu$ m) to ensure high-accuracy positioning.

The SV-3200 series manifest high-reliability especially in the horizontal roughness parameters (S, Sm), that require high-accuracy of the X-axis travel.

- When equipped with high accuracy Y-axis table and 3D surface analysis software MCubeMap, this offers CNC type capabilities usually performed on Extreme series machines.
- Various optional detector holders such as Crank Rotary type and Manual Rotary type make this versatile for many different applications.
- New optional Digital Automatic Tilt (DAT) function is best suited for workpieces that are too large for leveling tables.

### Technical Data

X-axis	
Measuring range:	4" or 8" (100mm or 200mm)
Resolution:	1.97 $\mu$ m (0.05 $\mu$ m)
Measurement method:	Linear encoder
Drive speed:	0 - 3.1"/s (0 - 80mm/s)
Measuring speed:	.00078 - .78"/s (0.2 - 20mm/s)**
Traversing direction:	Backward
Traverse linearity:	4": (2+L) $\mu$ m (0.05+0.001L) $\mu$ m* 8": 20 $\mu$ m / 8" (0.5 $\mu$ m/200mm)
Z2-axis (column)	
Vertical travel:	12", 20" or 27.6" (300mm, 500mm or 700mm) power drive
Resolution:	39.4 $\mu$ m (1 $\mu$ m)
Measurement method:	ABSOLUTE linear encoder
Drive speed:	0 - 1.2"/s (0 - 30mm/s)
Detector	
Range / resolution:	32000 $\mu$ m / .4 $\mu$ m, 3200 $\mu$ m / .04 $\mu$ m, 320 $\mu$ m / .004 $\mu$ m (up to 96000 $\mu$ m with an optional stylus) {800 $\mu$ m / 0.01 $\mu$ m, 80 $\mu$ m / 0.001 $\mu$ m, 8 $\mu$ m / 0.0001 $\mu$ m) (up to 2400 $\mu$ m with an optional stylus)}
Detecting method:	Skidless / skid measurement
Measuring force:	0.75mN (low force type)
Stylus tip:	Diamond, 60°/2 $\mu$ mR (low-force type)
Skid radius of curvature:	1.57" (40mm)
Detecting method:	Differential inductance
Base size (W x H):	23.6 x 17.7" (600 x 450mm) or 39.4 x 17.7" (1000 x 450mm)
Base material:	Granite

\*L = Measured length inch (mm)

\*\*Recommended speed: under 5mm/s

If using higher speed, stylus tip may be chipped and/or accuracy may be worse, depending on surface condition.

### Evaluation Capability: FORMTRACEPAK V5

Assessed profiles

P (primary profile), R (roughness profile), WC, WCA, WE, WEA, DIN4776 profile, envelope residual profile, roughness motif, waviness motif

Evaluation parameters

Ra, Rq, Rz, Ry, Rz(JIS), Ry(DIN), Rc, Rp, Rpmax, Rpi, Rv, Rvmax, Rvi, Rt, Rti, R3z, R3zi, R3y, S, Pc (Ppi), Sm, HSC, mr,  $\delta$ c, plateau ratio, mrd, Rk, Rpk, Rvk, Mr1, Mr2,  $\Delta$ a,  $\Delta$ q,  $\lambda$ a,  $\lambda$ q, Sk, Ku, Lo, Lr, A1, A2

Roughness motif parameters: Rx, R, AR, SR, SAR, NR, NCRX, CPM

Waviness motif parameters: Wte, Wx, W, AW SW, SAW, NW

Analysis graphs

ADC, BAC1, BAC2, power spectrum chart, auto-correlation chart, Walsh power spectrum chart, Walsh auto-correlation chart, slope distribution chart, local peak distribution chart, parameter distribution chart

Digital filter 2CR-75%, 2CR-50%, 2CR-75% (phase corrected), 2CR-50% (phase corrected), Gaussian-50%

Cutoff length\*

$\lambda$ c: .001, .003, .01, .03, .1, .3, 1"  
(0.025mm, 0.08mm, 0.25mm, 0.8mm, 2.5mm, 8mm, 25mm)

fl: .001, .003, .01, .03, .1, .3, 1"  
(0.08mm, 0.25mm, 0.8mm, 2.5mm, 8mm, 25mm)

fh: .001, .003, .01, .03, .1, .3, 1"  
(0.08mm, 0.25mm, 0.8mm, 2.5mm, 8mm)

Sampling length (L)\*.001, .003, .01, .03, .1, .3, 1"  
(0.025mm, 0.08mm, 0.25mm, 0.8mm, 2.5mm, 8mm, 25mm)

Data compensation functions

Tilt compensation, R-plane (curved surface) compensation, ellipse compensation, parabola compensation, hyperbola compensation, quadric curve automatic compensation, polynomial compensation, polynomial automatic compensation

\*Arbitrary length can be specified in the range from .001" (0.025mm) to the maximum traverse length.

# Surftest SV-3200

## SERIES 178 — Surface Roughness Testers

### SPECIFICATIONS

 Models without X-axis inclination function

Model No.	SV-3200S4	SV-3200H4	SV-3200W4	SV-3200L4
Order No. (inch)	<b>178-424-11A</b>	<b>178-425-11A</b>	<b>178-426-11A</b>	<b>178-464-11A</b>
Order No. (inch)	<b>178-444-11A</b>	<b>178-445-11A</b>	<b>178-446-11A</b>	<b>178-484-11A</b>
Measuring force of detector	0.75mN	0.75mN	0.75mN	0.75mN
X-axis measuring range	4" (100mm)	4" (100mm)	4" (100mm)	4" (100mm)
Vertical travel	12" (300mm) power column	20" (500mm) power column	20" (500mm) power column	27.6" (700mm) power column
Granite base size (WxD)	23.6 x 17.7" (600 x 450mm)	23.6 x 17.7" (600 x 450mm)	39.4 x 17.7" (1000 x 450mm)	39.4 x 17.7" (1000 x 450mm)
Dimensions (main unit, WxDxH)	29.8 x 19.0 x 38.0" (756 x 482 x 966mm)	29.8 x 19.0 x 45.9" (756 x 482 x 1166mm)	45.5 x 19.0 x 46.3" (1156 x 482 x 1176mm)	45.5 x 19.0 x 56.5" (1156 x 482 x 1436mm)
Mass (main unit)	308 lbs (140kg)	330 lbs (150kg)	485 lbs (220kg)	595 lbs (270kg)

Model No.	SV-3200S8	SV-3200H8	SV-3200W8	SV-3200L8
Order No. (inch)	<b>178-427-11A</b>	<b>178-428-11A</b>	<b>178-429-11A</b>	<b>178-465-11A</b>
Order No. (inch)	<b>178-447-11A</b>	<b>178-448-11A</b>	<b>178-449-11A</b>	<b>178-485-11A</b>
Measuring force of detector	0.75mN	0.75mN	0.75mN	0.75mN
X-axis measuring range	8" (200mm)	8" (200mm)	8" (200mm)	8" (200mm)
Vertical travel	12" (300mm) power column	20" (500mm) power column	20" (500mm) power column	27.6" (700mm) power column
Granite base size (WxD)	23.6 x 17.7" (600 x 450mm)	23.6 x 17.7" (600 x 450mm)	39.4 x 17.7" (1000 x 450mm)	39.4 x 17.7" (1000 x 450mm)
Dimensions (main unit, WxDxH)	30.2 x 19.0 x 38.0" (766 x 482 x 966mm)	30.2 x 19.0 x 45.9" (766 x 482 x 1166mm)	45.9 x 19.0 x 46.3" (1166 x 482 x 1176mm)	45.5 x 19.0 x 56.5" (1156 x 482 x 1436mm)
Mass (main unit)	308 lbs (140kg)	330 lbs (150kg)	485 lbs (220kg)	595 lbs (270kg)

### Optional Accessories

- 178-602-1:** Reference Specimen (Supports ISO)
  - 178-611:** Reference Step Specimen (2µm, 10µm)
  - 178-612:** Reference Step Specimen (2µm, 10µm, 79µin, 394µin)
  - 178-610:** Step gage (1µm, 2µm, 5µm, 10µm)
  - 178-047:** Three-axis adjustment table (including 998291 precision V-block.)
  - 178-016:** Leveling table
  - 178-042-1:** Digimatic XY leveling table (25 x 25mm)
  - 178-052-1:** Digimatic XY leveling table (1 x 1")
  - 178-043-1:** XY leveling table (25 x 25mm)
  - 178-053-1:** XY leveling table (1 x 1")
  - 178-019:** Precision vise\*
  - 998291:** Precision V-block\*
  - 181-902-10:** V-block set with clamp (Max. workpiece dia.: 25mm)
  - 181-901-10:** V-block set with clamp (Max. workpiece dia.: 1")
- (See page J-22/23.) Detectors, styli, and nosepieces  
\*Use with an XY leveling table

### Optional Accessories

A wide range of peripherals are available to support various challenging measurement needs.



Y-axis Table  
**178-097** for multiple workpiece measurement  
**178-096** for 3D measurement  
\*Not a measuring axis, only for positioning.



3D-Auto Leveling Table  
**178-077**  
\*Used together with **178-096**



Digital Advanced Tilting Unit  
**178-040**  
\*Contact Sales Rep for details. Recommend to be installed in manufacturer's facility.  
(See page J-25 for more accessories.)



**178-071** (S-3000)  
Standard Detector Holder



**178-075** (S-3000CR)  
Crank Rotary Type Detector Holder



**178-074** (S-3000C)  
Crank Type Detector Holder



**178-076** (S-3000MR)  
Manual Rotary Type Detector Holder

# Surftest Extreme SV-3000CNC

## SERIES 178 — CNC Surface Measuring Instruments

### FEATURES

- High-accuracy CNC surface roughness measuring instrument allows surface roughness measurement in both axes.
- Each axes has the maximum drive speed of 200 mm/s, which permits high-speed positioning that may result in a large increase in the throughput of multiple-profile/multiple-workpiece measurement tasks.
- For models with the  $\alpha$ -axis, it is possible to perform continuous measurement over horizontal and inclined surfaces by power-tilting the drive unit.
- For models with the Y-axis table, it is possible to expand the measuring range for multiple workpieces, etc., through positioning in the Y-axis direction.
- Using optional rotary table  $\theta 1$  and  $\theta 2$  designed to use with the CNC models enables it to expand the CNC measurement application range.
- Inclined plane measurements is possible through 2-axis simultaneous control in the X- and Y-axis directions.
- Since the detector unit incorporates an anti-collision safety device, the detector unit will automatically stop even if its main body collides with a workpiece or fixture.
- Supplied with an easy-to-operate Remote Box. The user can make any movement by selecting the required axis using the two joysticks. The current axis selection is easily identified by the icon on the key top.
- Communication with the data processing/analysis section is via USB.



SV-3000CNC w/ PC system and software  
PC stand is not included, isolation stand is optional

### SPECIFICATIONS

Model No.	SV-3000CNC		SV-3000CNC	
Order No. (100V - 120V)	178-508-13	178-528-13	178-509-13	178-529-13
X1-axis measuring range	8" (200mm)	8" (200mm)	8" (200mm)	8" (200mm)
Z2-axis vertical travel	12" (300mm)	20" (500mm)	12" (300mm)	20" (500mm)
Y-axis table unit	Installed	Installed	Installed	Installed
$\alpha$ -axis unit	—	—	Installed	Installed

### Technical Data: SV-3000CNC

X1-axis	Measuring range: 8" (200mm)
	Resolution: 1.97 $\mu$ m (0.05 $\mu$ m)
	Measurement method: Reflective-type linear encoder
	Drive speed: 7.87"/s (200mm/s) (CNC, max.)
	0 - 2.0"/s (0 - 50mm/s) (joystick)
	Measuring speed: .00078 - .078"/s (0.02 - 2mm/s)
	Traversing direction: Backward
	Traverse linearity: 20 $\mu$ m/8" (0.5 $\mu$ m/200mm)
$\alpha$ -axis**	Inclination angle: -45° to +10°
	Resolution: 0.000225°
	Rotating speed: 1rpm
Z2-axis (column)	Vertical travel: 12" (300mm) 20"*(500mm)
	Resolution: 1.97 $\mu$ m (0.05 $\mu$ m)
	Measurement method: Reflective-type linear encoder
	Drive speed: 7.87"/s (200mm/s) (max., CNC)
	0 - 2.4"/s (0 - 60mm/s) (joystick)
	Base size (W x H): 29.5 x 23.6" (750 x 600mm)
	Base material: Granite
Detector	Range / resolution: 32000 $\mu$ m / .4 $\mu$ m, 3200 $\mu$ m / .04 $\mu$ m, 320 $\mu$ m / .004 $\mu$ m (up to 96,000 $\mu$ m with an optional stylus) (800 $\mu$ m / 0.01 $\mu$ m, 80 $\mu$ m / 0.001 $\mu$ m, 8 $\mu$ m / 0.0001 $\mu$ m) (up to 2400 $\mu$ m with an optional stylus)
	Measuring force: 4mN (0.75mN) (low-force type)
	Stylus tip: Diamond, 90°/5 $\mu$ mR (60°/2 $\mu$ mR: low-force type)
Dimension (W x D x H):	31.5 x 24.4 x 39.4" (800 x 620 x 1000mm)
	31.5 x 24.4 x 47.2" (800 x 620 x 1200mm)*
Mass	529 lbs (240kg) 551lbs (250kg)*
	*High-column model
Y-axis table unit**	Measuring range: 8" (200mm)
	Minimum reading: 1.97 $\mu$ m (0.05 $\mu$ m)
	Scale unit: Reflective-type Linear Encoder
	Drive speed: 7.87"/s (200mm/s) (max., CNC)
	0 - 2.4"/s (0 - 60mm/s) (joystick)
Maximum loading capacity:	44 lbs (20kg)
Traverse linearity	20 $\mu$ m/8" (0.5 $\mu$ m/200mm)
Linear displacement accuracy (at 20°C):	$\pm$ (80+2L/4) $\mu$ m ( $\pm$ (2+2L/100) $\mu$ m)
	L: Dimension between two measured points (mm)
Table size:	7.87 x 7.87" (200 x 200mm)
Dimensions (W x D x H):	12.6 x 25.4 x 4.1" (320 x 646 x 105mm)
Mass:	77 lbs (35kg)
	**Y-axis table included only as a factory installed option.

### Optional Accessories

Vibration isolation stand	Vibration isolation mechanism: Diaphragm air spring
Natural frequency :	2.5 - 3.5Hz
Damping mechanism:	Orifice
Leveling mechanism:	Automatic control with mechanical valves
Air supply pressure:	0.4MPa
Allowable loading capacity:	772 lbs (350kg)
Dimensions (W x D x H):	39.4 x 35.2 x 28.1" (1000 x 895 x 715mm)
Mass:	617 lbs (280kg)

## Technical Data: SV-M3000CNC

### X1-axis

Measuring range: 8" (200mm)  
 Resolution: 1.97µin (0.05µm)  
 Measurement method: Reflective-type linear encoder  
 Drive speed: 7.87"/s (200mm/s) (max., CNC)  
 0 - 1.97"/s (0 - 50mm/s) (joystick)  
 Measuring speed: .00078 - .08"/s (0.02 - 2mm/s)  
 Traverse linearity: 20µin/8" (0.5µm/200mm)  
 28µin/8" (0.7µm/200mm)  
 (long-type detector)  
 20µin/8" (0.5µm/200mm)  
 (rotary-type detector,  
 up/down direction)  
 28µin/8" (0.7µm/200mm)  
 (long-type detector,  
 forward/backward direction)

### α-axis

Inclination angle: -45° to +10°  
 Resolution: 0.000225°  
 Rotating speed: 1rpm

### Z2-axis (column)

Vertical travel: 20" (500mm)  
 Resolution: 1.97µin (0.05µm)  
 Measurement method: Reflective-type linear encoder  
 Drive speed: 7.87"/s (200mm/s) (CNC, max.)  
 0 - 1.97"/s (0 - 50mm/s) (joystick)

### Y-axis

Measuring range: 32" (800mm)  
 Resolution: 1.97µin (0.05µm)  
 Measurement method: Reflective-type linear encoder  
 Drive speed: 7.87"/s (200mm/s) (max., CNC)  
 0 - 1.97"/s (0 - 50mm/s) (joystick)  
 Measuring speed: .00078 - .08"/s (0.02 - 2mm/s)  
 Traverse linearity: 20µin/2" (0.5µm/50mm), 80µin/32"  
 (2µm/800mm) 28µin/2" (0.7µm/50mm),  
 120µin/32" (3µm/800mm)  
 (long-type detector)  
 28µin/2" (0.7µm/50mm),  
 120µin/32" (3µm/800mm)  
 (rotary-type detector, up/down direction)

### Base unit

Size (W x H): 23.6 x 59.1" (600 x 1500mm)  
 Material: Steel  
 Loading capacity: 661 lbs (300kg)

### Detector

Range / resolution: 32000µin / .4µin, 3200µin / .04µin,  
 320µin / .004µin  
 (up to 96,000µin with an optional stylus)  
 {800µm / 0.01µm, 80µm / 0.001µm,  
 8µm / 0.0001µm (up to 2400µm with  
 an optional stylus)}  
 Detecting method: Skidless / skid measurement  
 Measuring force: 4mN or 0.75mN (low-force type)  
 Stylus tip: Diamond, 90°/5µmR  
 (60°/2µmR: low-force type)  
 Skid radius of curvature: 1.57" (40mm)  
 Detecting method: Differential inductance  
 Dimension (W x D x H): 42.7 x 66.7 x 75.7"  
 (1085 x 1695 x 1922mm)  
 Mass: 3527 lbs (1600Kg)  
 (including vibration isolating unit)

**MiCAT**

Mitutoyo Intelligent Computer Aided Technology

the standard in world  
 metrology software  
**FORM**

## Software

### FORMTRACEPAK V5

Enables control of the optional motor-driven Y-axis table and rotary table for realizing efficient measurement automation. You can also perform contour evaluation that allows free analysis of level differences, angle, pitch, area and other characteristics based on surface roughness data. In addition, analysis results can be saved in the "html", "mhtml" or pdf format which allows Internet Explorer or MS-Word compatibility, allowing PC without layout editing programs to view analysis results.



Contour Measurement & Surface Roughness Measurement Screen



Report Layout Screen

# Surftest Extreme SV-M3000CNC

## SERIES 178 — CNC Surface Measuring Instruments



SV-M3000CNC with personal computer system and software

\* PC stand not included

## FEATURES

- CNC Surface Roughness Tester covers measurement of large/heavy workpieces such as engine blocks, crankshafts, etc.
- In combination with the surface roughness detector rotating unit, S-3000AR (optional), it can perform continuous measurement over the bottom, top and side surfaces of a workpiece.
- Compatible with the optional large table for supporting a load of 220 lbs (100 kg) or a large Ø2 table. Enables continuous automatic measurement of large-size workpieces.
- Suitable for automatic surface roughness measurement on large and heavy workpieces.
- Employs the column-moving type configuration that is not restricted by workpiece size. This is advantageous for measuring heavy workpieces, such as engine blocks, crankshafts, etc.
- Provides 31.5" (800mm) of Y-axis stroke. This makes it possible to measure multiple profiles on large workpieces.
- Load table has a self-contained structure to ensure that various size workpieces, jigs, auto-feed devices, etc., are easily accommodated and can be specified, if required, by special order.

## SPECIFICATIONS

Model No.	SV-M3000CNC
Order No. (100V - 120V)	178-549-1
X1-axis measuring range	8" (200mm)
Z2-axis column travel range	20" (500mm)
Y-axis travel range	32" (800mm)
α-axis inclination angle	-45° (CCW), +10° (CW)

# Formtracer SV-C3200 / SV-C4500

## SERIES 525 — Surface Roughness / Contour Measuring System



### FEATURES

- Dramatically increased drive speed (X axis: 3.1"/s (80mm/s), Z2 axis column: 1.2"/s (30mm/s) further reduces total measurement time.
- In order to maintain the traverse linearity specification for an extended period of time, Mitutoyo has adopted highly rigid ceramic guides that combine the characteristics of smallest secular change and remarkable resistance to abrasion.
- The drive unit (X-axis) and column (Z2-axis) are equipped with a high-accuracy linear encoder (ABS type on Z2-axis). This improves reproducibility of continuous automatic measurement of small holes in the vertical direction and repeated measurement of parts which are difficult to position.

### Automatic Measurement

- A wide range of optional peripherals are available to support quick and easy CNC operation.



### Surface Roughness Measurement

- Traverse linearity:  $(2+1L)\mu\text{in}$  ( $\pm(0.05+0.001L)\mu\text{m}^*$ )  
Designed to handle workpieces calling for high accuracy.  
\*S4, H4, W4 types, L = Drive length inch (mm)
- Compliant with JIS '82/'94/'01, ISO, ANSI, DIN, VDA, and other international surface roughness standards.
- Equipped with a standard high accuracy detector (0.75mN/4mN measuring force) providing a resolution down to 0.004 $\mu\text{in}$  (0.0001 $\mu\text{m}$ ).

### Contour Drive Measurement

- X axis accuracy:  $\pm(31.5+10L)\mu\text{in}$  ( $\pm(0.8+0.01L)\mu\text{m}^*$ )  
Z1-axis accuracy:  $\pm(31.5+120H)\mu\text{in}$  ( $\pm(0.8+12H/100)\mu\text{m}^*$ )  
Designed to handle workpieces calling for high accuracy.  
\*S4, H4, W4 types, L = Drive length, H = Measurement height inch (mm)
- The contour drive unit of SV-C4500 series instruments can continuously measure in the upward and downward directions without the need to change the arm orientation or reset the workpiece, when combined with the double cone-end stylus (a new product with contact points in the upward and downward directions).

### Technical Data: Common

Power supply: 100 - 240VAC  $\pm 10\%$ , 50/60Hz  
Power consumption: 400W (main unit only)

### Technical Data: Contour Measurement

X-axis  
Measuring range: 4" (100mm) or 8" (200mm)  
Resolution: 1.97 $\mu\text{in}$  (0.05 $\mu\text{m}$ )  
Measurement method: Reflective-type linear encoder  
Drive speed: 3.1"/s (80mm/s) and manual  
Measuring speed: .00078 - .78"/s (0.02 - 20mm/s)\*

\*Recommended speed: under 5mm/s  
If using higher speed, stylus tip may be chipped and/or accuracy may be worse, depending on surface condition.

Measuring direction: Forward/backward  
Traverse linearity: 32 $\mu\text{in}/4"$  (0.8 $\mu\text{m}/100\text{mm}$ )  
79 $\mu\text{in}/8"$  (2 $\mu\text{m}/200\text{mm}$ )  
\*with the X axis in horizontal orientation  
Linear displacement:  $\pm(32+10L)\mu\text{in}$  ( $\pm 0.8+0.01L\mu\text{m}$ )  
(SV-C3200S4, H4, W4)  
accuracy (at 20°C)  $\pm(32+10L)\mu\text{in}$  ( $\pm 0.8+0.01L\mu\text{m}$ )  
(SV-C4500S4, H4, W4)  
 $\pm(32+20L)\mu\text{in}$  ( $\pm 0.8+0.02L\mu\text{m}$ )  
(SV-C3200S8, H8, W8)  
 $\pm(32+20L)\mu\text{in}$  ( $\pm 0.8+0.02L\mu\text{m}$ )  
(SV-C4500S8, H8, W8)  
\* L = Drive length inch (mm)

Inclination range:  $\pm 45^\circ$   
Z2-axis (column)  
Vertical travel: 12" (300mm) or 20" (500mm)  
Resolution: 39.4 $\mu\text{in}$  (1 $\mu\text{m}$ )  
Measurement method: ABSOLUTE linear encoder  
Drive speed: 0 - 1.2"/s (0 - 30mm/s) and manual  
Z1-axis (detector unit)  
Measuring range:  $\pm 1.2"$  ( $\pm 30\text{mm}$ )  
Resolution: 1.57 $\mu\text{in}$  (0.04 $\mu\text{m}$ ) (SV-C3200 series),  
.78 $\mu\text{in}$  (0.02 $\mu\text{m}$ ) (SV-C4500 series)

Measurement method: Linear encoder (SV-C3200 series),  
Laser hologage (SV-C4500 series)  
Linear displacement:  $\pm(63+120H)\mu\text{in}$  ( $\pm(1.4+12H/100)\mu\text{m}$ )  
(SV-C3200 series)  
accuracy (at 20°C)  $\pm(31.5+120H)\mu\text{in}$   
( $\pm(0.8+12H/100)\mu\text{m}$ ) (SV-C4500 series)  
\*H: Measurement height from the horizontal position (mm)

Stylus up/down operation: Arc movement  
Face of stylus: Upward/downward (SV-C3200)  
Upward/downward (Direction switch by Formtracepak) (SV-C4500)  
Measuring force: 30mN (SV-C3200)  
10, 20, 30, 40, 50mN (SV-C4500)  
\* As for SV-C4500, set the measurement force with Formtracepak.  
Traceable angle: Ascent: 77°, descent: 83°  
(using the standard stylus provided and depending on the surface roughness)  
Stylus tip  
Radius: 25 $\mu\text{m}$ , carbide tip

### Technical Data: Surface Roughness Measurement

X1-axis  
Measuring range: 4" (100mm) or 8" (200mm)  
Resolution: 1.97 $\mu\text{in}$  (0.05 $\mu\text{m}$ )  
Measurement method: Linear encoder  
Drive speed: 3.1"/s (80mm/s)  
Traversing direction: Backward  
Traverse linearity:  $(2+1L)\mu\text{in}$  (0.05+1L/1000) $\mu\text{m}$   
(S4, H4, W4 types)  
20 $\mu\text{in}/8"$  (0.5 $\mu\text{m}/200\text{mm}$ )  
(S8, H8, W8 types)

Z2-axis (column)  
Vertical travel: 12" (300mm) or 20" (500mm)  
Resolution: 39.4 $\mu\text{in}$  (1 $\mu\text{m}$ )  
Measurement method: ABSOLUTE linear encoder  
Drive speed: 0 - 1.2"/s (0 - 30mm/s) and manual  
Detector  
Range / resolution: 32000  $\mu\text{in}$  / .4  $\mu\text{in}$ , 3200 $\mu\text{in}$  / .04 $\mu\text{in}$ ,  
320  $\mu\text{in}$  / .004 $\mu\text{in}$   
(up to 96000  $\mu\text{in}$  with an optional stylus)  
{800 $\mu\text{m}$  / 0.01 $\mu\text{m}$ , 80 $\mu\text{m}$  / 0.001 $\mu\text{m}$ ,  
8 $\mu\text{m}$  / 0.0001 $\mu\text{m}$  (up to 2400 $\mu\text{m}$  with an optional stylus)}  
Detecting method: Skidless / skid measurement  
Measuring force: 0.75mN (low force type)  
Stylus tip: Diamond  
60°/2 $\mu\text{mR}$  (low force type)  
Skid radius of curvature: 1.57" (40mm)  
Detecting method: Differential inductance

# Formtracer SV-C3200 / SV-C4500

## SERIES 525 — Surface Roughness / Contour Measuring System

### SPECIFICATIONS

Model No.	SV-C3200S4	SV-C3200H4	SV-C3200W4	SV-C3200L4
Order No. (inch)	<b>525-491-11A</b>	<b>525-492-11A</b>	<b>525-493-11A</b>	<b>525-494-11A</b>
Model No.	SV-C4500S4	SV-C4500H4	SV-C4500W4	SV-C4500L4
Order No. (inch)	<b>525-451-11A</b>	<b>525-452-11A</b>	<b>525-453-11A</b>	<b>525-454-11A</b>
X1-axis measuring range	4" (100mm)	4" (100mm)	4" (100mm)	4" (100mm)
Measuring force of detector	0.75mN	0.75mN	0.75mN	0.75mN
Vertical travel	12" (300mm) power column	20" (500mm) power column	20" (500mm) power column	27.6" (700mm) power column
Granite base size (WxD)	23.6 x 17.7" (600 x 450mm)	23.6 x 17.7" (600 x 450mm)	39.4 x 17.7" (1000 x 450mm)	39.4 x 17.7" (1000 x 450mm)
Dimensions (main unit, WxDxH)	39.2 x 22.6 x 38.0" (996 x 575 x 966mm)	39.2 x 22.6 x 46.3" (996 x 575 x 1176mm)	55.4 x 22.6 x 46.3" (1396 x 575 x 1176mm)	55.4 x 22.6 x 56.1" (1396 x 575 x 1426mm)
Mass (main unit)	308 lbs (140kg)	330 lbs (150kg)	485 lbs (220kg)	595 lbs (270kg)
Model No.	SV-C3200S8	SV-C3200H8	SV-C3200W8	SV-C3200WL8
Order No. (inch)	<b>525-496-11A</b>	<b>525-497-11A</b>	<b>525-498-11A</b>	<b>525-499-11A</b>
Model No.	SV-C4500S8	SV-C4500H8	SV-C4500W8	SV-C4500L8
Order No. (inch)	<b>525-456-11A</b>	<b>525-457-11A</b>	<b>525-458-11A</b>	<b>525-459-11A</b>
X1-axis measuring range	8" (200mm)	8" (200mm)	8" (200mm)	4" (100mm)
Measuring force of detector	0.75mN	0.75mN	0.75mN	0.75mN
Vertical travel	12" (300mm) power column	20" (500mm) power column	20" (500mm) power column	27.6" (700mm) power column
Granite base size (WxD)	23.6 x 17.7" (600 x 450mm)	23.6 x 17.7" (600 x 450mm)	39.4 x 17.7" (1000 x 450mm)	39.4 x 17.7" (1000 x 450mm)
Dimensions (main unit, WxDxH)	39.6 x 22.6 x 38.0" (1006 x 575 x 966mm)	39.6 x 22.6 x 46.3" (1006 x 575 x 1176mm)	55.4 x 22.6 x 46.3" (1406 x 575 x 1176mm)	55.4 x 22.6 x 56.1" (1396 x 575 x 1426mm)
Mass (main unit)	308 lbs (140kg)	330 lbs (150kg)	485 lbs (220kg)	595 lbs (270kg)

**MiCAT**

Mitutoyo Intelligent Computer Aided Technology

the standard in world  
metrology software  
**FORM**

### Software

#### FORMTRACEPAK V5

Enables control of the optional motor-driven Y-axis table and rotary table for realizing efficient measurement automation. You can also perform contour evaluation that allows free analysis of level differences, angle, pitch, area and other characteristics based on surface roughness data. In addition, analysis results can be saved in the "html", "mhtml" or pdf format which allows Internet Explorer or MS-Word compatibility, allowing PC without layout editing programs to view analysis results.

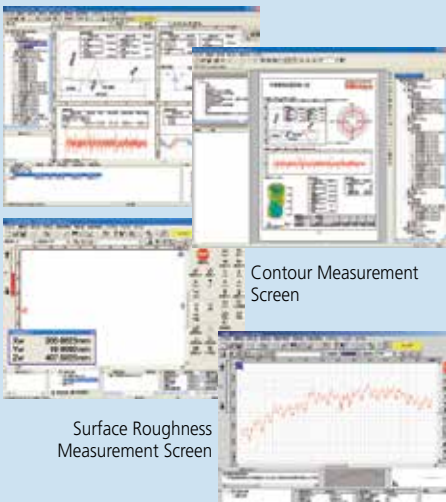

Contour Measurement Screen

Surface Roughness Measurement Screen

### Optional Accessories

A wide range of peripherals are available to support various challenging measurement needs.



Y-axis Table  
**178-097** for multiple workpiece measurement  
**178-096** for 3D measurement  
\*Not a measuring axis, only for positioning.

(See page J-25 for more accessories.)



3D-Auto Leveling Table  
**178-077**  
\*Used together with 178-096



**178-071** (S-3000)  
Standard Detector Holder



**178-091** (S-3000CR)  
Crank Rotary Type Detector Holder



**178-074** (S-3000C)  
Crank Type Detector Holder



**178-092** (S-3000MR)  
Manual Rotary Type Detector Holder

# Formtracer Extreme SV-C4500CNC

## SERIES 525 — Surface Roughness/Form Measuring Instrument



SV-C4500CNC with recommended machine vibration stand

\* PC stand not included

Surface roughness detector



Contour Z-axis detector



### FEATURES

- High-accuracy CNC surface roughness/form measuring instrument allows both measurement of surface roughness and form/contour with one unit.
- Each axes has the maximum drive speed of 7.87"/s (200 mm/s), which permits high-speed positioning that may result in a large increase in the throughput of multiple-profile/multiple-workpiece measurement tasks.
- For models with the  $\alpha$  axis, it is possible to perform continuous measurement over horizontal and inclined surfaces by power-tilting the detector unit.
- For models with the Y-axis table, it is possible to expand the measuring range for multiple workpieces, etc., through positioning in the Y-axis direction.
- When combined with the double cone-end stylus (a new product with diametrically opposed contact points), the instrument can continuously measure in the upward and downward directions without the need to change the arm orientation or reset the workpiece fixturing.
- The measuring force can be switched among five levels (upward and downward) from the data-processing program (Formtracepak).
- Enables inclined plane measurements through 2-axis simultaneous control in the X- and Y-axis directions.
- When the detector for form/contour measurement is replaced with that for surface roughness measurement, or vice versa, it is a simple, one-touch replacement without re-routing of the connecting cables.
- Since the Z1-axis detector incorporates an anti-collision safety device, the detector unit will automatically stop even if its main body collides with a workpiece or fixture.
- Supplied with an easy-to-operate Remote Box. The user can make any movement by selecting the required axis using the two joysticks. The current axis selection is easily identified by the icon on the key top.
- Communication with the Data Processing/Analysis section is via USB.

### Technical Data: Common

Base size (W x H):	31 x 39.4" (800 x 1000mm) Type S 34 x 47.2" (800 x 1200mm) Type H
Base material:	Granite
Mass:	529 lbs (240kg) Type S 551 lbs (250kg) Type H
Power supply:	100 – 120VAC $\pm 10\%$ , 50/60Hz
Power consumption:	500W (main unit only)

### Technical Data: Contour Measurement

X1-axis	
Measuring range:	8" (200mm)
Resolution:	1.97 $\mu$ m (0.05 $\mu$ m)
Measurement method:	Reflective-type linear encoder
Drive speed:	7.87"/s (200mm/s) (max., CNC) 0 - 2"/s (0 - 50mm/s) (joystick)
Measuring speed:	.00078 - .08"/s (0.02 - 2mm/s)
Measuring direction:	Forward / Backward
Traverse linearity:	80 $\mu$ m / 8" (2 $\mu$ m/200mm) *with the X axis in horizontal orientation
Linear displacement accuracy (at 20°C):	$\pm(0.8+4L/200)$ mm * L = Drive length (mm)
$\alpha$ -axis* Depends on Code #	
Inclination angle:	-45° to +10°
Resolution:	0.000225°
Rotating speed:	1rpm
Z2-axis (column)	
Vertical travel:	12" or 20" (300mm or 500mm)
Resolution:	1.97 $\mu$ m (0.05 $\mu$ m)
Measurement method:	Reflective-type linear encoder
Drive speed:	7.87"/s (200mm/s) (max., CNC) 0 - 2"/s (0 - 50mm/s) (joystick)
Z1-axis (detector unit)	
Measuring range:	$\pm 1.2"$ ( $\pm 30$ mm)
Resolution:	.787 $\mu$ m (0.02 $\mu$ m)
Measurement method:	Reflective Type detector unit
Linear displacement:	Accuracy (at 20°C) $\pm(32+110H)\mu$ m ( $\pm(0.8+12H/100)\mu$ m) *H: Measurement height from the horizontal position (mm) w/o $\alpha$ -axis: $\pm(1.5+10H/1000)\mu$ m
Stylus up/down operation:	Arc movement
Face of stylus:	Downward
Measuring force:	10, 20, 30, 40, 50mN
Traceable angle:	Ascent: 70°, descent: 70° (using the standard stylus provided and depending on the surface roughness)
Stylus tip	Radius: 25 $\mu$ m, carbide tip

### Technical Data: Surface Roughness Measurement

X1-axis	
Measuring range:	8" (200mm)
Resolution:	1.97 $\mu$ m (0.05 $\mu$ m)
Measurement method:	Reflective-type linear encoder
Drive speed:	7.87"/s (200mm/s) (max., CNC) 0 - 2"/s (0 - 50mm/s) (joystick)
Measuring speed:	.00078 - .08"/s (0.02 - 2mm/s)
Traversing direction:	Pulling
Traverse linearity:	20 $\mu$ m/8" (0.5 $\mu$ m/200mm)
$\alpha$ -axis* Depends on Code #	
Inclination angle:	-45° to +10°
Resolution:	0.000225°
Rotating speed:	1rpm
Z2-axis (column)	
Vertical travel:	12" or 20" (300mm or 500mm)
Resolution:	1.97 $\mu$ m (0.05 $\mu$ m)
Measurement method:	Reflective-type linear encoder
Drive speed:	7.87"/s (200mm/s) (max., CNC) 0 - 2"/s (0 - 50mm/s) (joystick)
Detector (optional)	
Range / resolution:	32000 $\mu$ m / .4 $\mu$ m, 3200 $\mu$ m / .04 $\mu$ m, 320 $\mu$ m / .004 $\mu$ m (up to 96000 $\mu$ m with an optional stylus) 800 $\mu$ m / 0.01 $\mu$ m, 80 $\mu$ m / 0.001 $\mu$ m, 8 $\mu$ m / 0.0001 $\mu$ m (up to 2400 $\mu$ m with an optional stylus)
Detecting method:	Skidless / skid measurement
Measuring force:	0.75mN
Stylus tip:	60°/2 $\mu$ mR
Skid radius of curvature:	1.57" (40mm)
Detecting method:	Differential inductance



# Formtracer Extreme SV-C4500CNC

## SERIES 525 — Surface Roughness/Form Measuring Instrument

### Y-axis table unit\*\*

Measuring range: 8" (200mm)  
 Minimum reading : 1.97µin (0.05µm)  
 Scale unit: Reflective-type linear encoder  
 Drive speed: 200mm/s (max., CNC)  
 0 - 2"/s (0 - 50mm/s) (joystick)

Maximum loading capacity: 44 lbs (20kg)  
 Traverse linearity 20µin/8" (0.5µm/200mm) Surface roughness  
 80µin/8" (2µm/200mm) contour

Linear displacement accuracy (at 20°C):  
 ± (80+20L)µin(± (2+2L/100) µm)  
 contour mode  
 L: Dimension between two measured  
 points (mm)

Table size: 7.8 x 7.8" (200 x 200mm)  
 Dimensions (W x D x H): 2.6 x 25.4 x 4.1"  
 (320 x 646 x 105mm)

Mass: 77 lbs (35kg)

\*\*Y-axis table included only as a factory installed option.

### Optional Accessories

#### Machine vibration stand: 12AAE032

Vibration isolation mechanism: Diaphragm air spring  
 Natural frequency : 2.5 - 3.5Hz  
 Damping mechanism: Orifice  
 Leveling mechanism: Automatic control with mechanical  
 valves

Air supply pressure: 0.4Mpa  
 Allowable loading capacity: 772 lbs (350kg)  
 Dimensions (W x D x H): 39.4 x 35.2 x 28.1"  
 (1000 x 895 x 715mm)

Mass: 617 lbs (280kg)



Mitutoyo Intelligent Computer Aided Technology  
 the standard in world  
 metrology software  
**FORM**

### Software

#### FORMTRACEPAK V5

Enables control of the optional motor-driven Y-axis table and rotary table for realizing efficient measurement automation. You can also perform contour evaluation that allows free analysis of level differences, angle, pitch, area and other characteristics based on surface roughness data. In addition, analysis results can be saved in the "html", "mhtml" or pdf format which allows Internet Explorer or MS-Word compatibility, allowing PC without layout editing programs to view analysis results.



Contour Measurement and Surface Roughness Measurement Screen

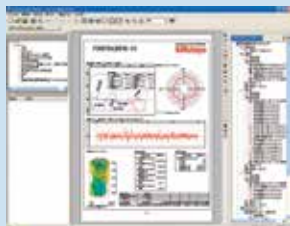

Report Layout Screen

### SPECIFICATIONS

Model No.	SV-C4500S CNC	SV-C4500H CNC
Order No. (100V - 120V)	525-674-1	525-694-1A
X1-axis measuring range	8" (200mm)	8" (200mm)
Z2-axis vertical travel	12" (300mm)	20" (500mm)
Y-axis table unit	Installed	Installed
α-axis unit	Installed	Installed
Granite base size (WxD)	29.5 x 23.6" (750 x 600mm)	29.5 x 23.6" (750 x 600mm)
Dimensions (main unit, WxDxH)	31.5 x 24.4 x 39.4" (800 x 620 x 1000mm)	31.5 x 24.4 x 47.2" (800 x 620 x 1200mm)
Mass (main unit)	529 lbs (240kg)	551 lbs (250kg)

### DIMENSIONS

Unit: mm

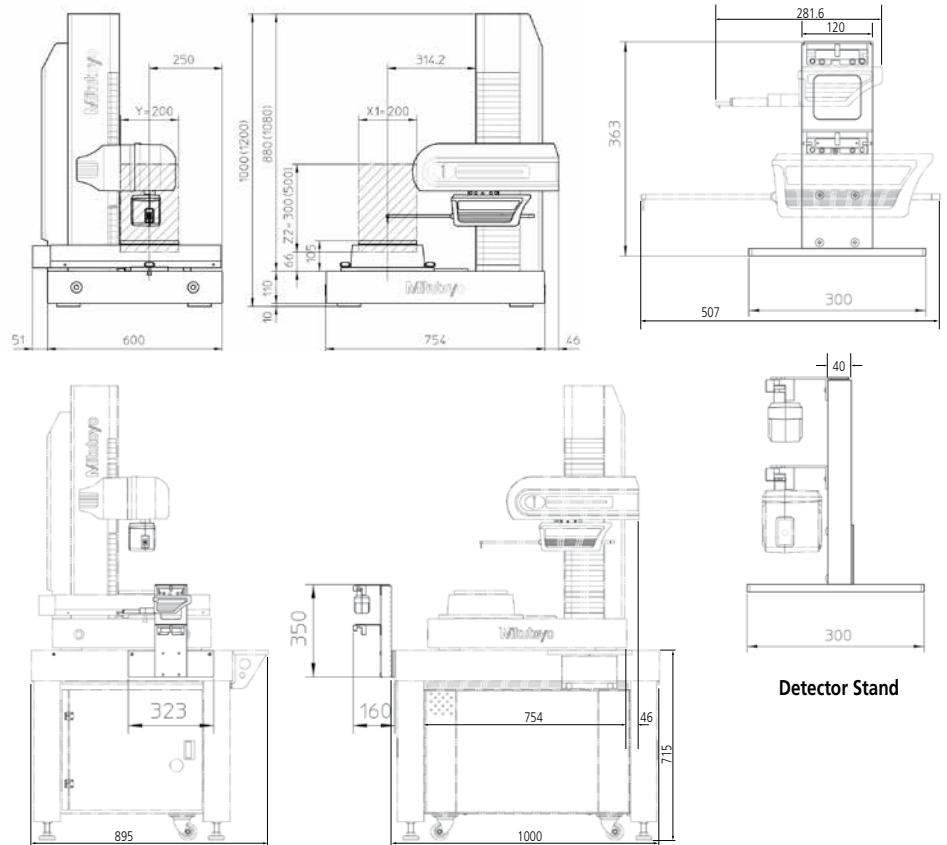

Detector Stand

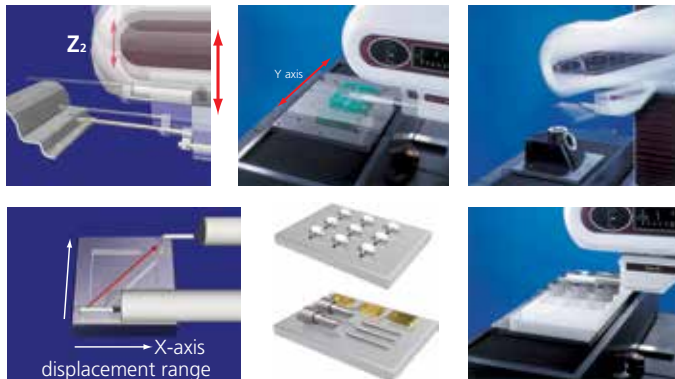

# Formtracer CS-3200

SERIES 525 — Form Measuring Instruments



**CS-3200S4 with personal computer system and software**  
\* PC stand not included.

## FEATURES

- Highest measurement accuracy in its class.  
X axis:  $\pm(1+0.01L)\mu\text{m}$   
Z1 axis:  $\pm(1.5+2H/100)\mu\text{m}$
- To detect surface roughness and contour in a single measurement the Z1-axis detector unit of CS-3200S4 has a wide measuring range and high resolution of 5mm / 0.08 $\mu\text{m}$  to 0.05mm / 0.0008 $\mu\text{m}$ .

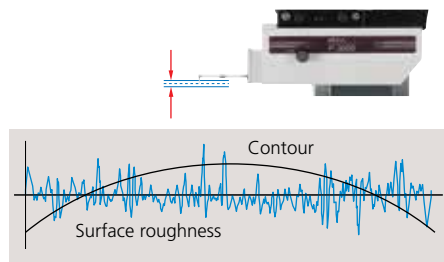

- The detector unit can be extended to avoid interference between the drive unit and workpiece. The measuring range is shifted to the left by 2.76" (70mm).



- In order to maintain the traverse linearity specification for an extended period of time, Mitutoyo has adopted highly rigid ceramic guides that combine the characteristics of smallest secular change and remarkable resistance to abrasion.
- Drastically increased drive speed further reduces total measurement time.  
X axis: 80mm/s, Z2 axis: 20mm/s
- To enhance safety during fast traverse, the Z-axis detector unit incorporates a safety device (Automatic Stop-On-Collision Mechanism).

- Incorporation of an ABS scale in the Z2 axis eliminates the need for origin point re-setting conventionally required for every step of repeated measurements over step or multiple sections.
- Small holes and inclined planes can be efficiently measured using the inclined X-axis drive unit and fine-feed handles on the X and Z2 axes.
- All detector and drive unit cables are housed inside the main unit to eliminate any risk of abrasion and guarantee trouble-free, high-speed operation.
- Orientation of the drive unit can be inclined by  $\pm 45^\circ$ . This allows CS-3200 to measure an inclined surface quickly.

## Technical Data: Contour Measurement

<b>X1-axis</b>	
Measuring range:	4" (100mm)
Resolution:	1.97 $\mu\text{m}$ (0.05 $\mu\text{m}$ )
Measurement method:	Reflective-type linear encoder
Drive speed:	0 - 3.1"/s (0 - 80mm/s) and manual
Measuring speed:	.00078 - .00787"/s (0.02 - 0.2mm/s) (surface roughness) 0.00078 - 0.0787"/s (0.02 - 2mm/s) (contour)
Measuring direction:	Forward / Backward
Traverse linearity:	8 $\mu\text{in}/4"$ (16 $\mu\text{in}/4"$ ) [0.2 $\mu\text{m}/100\text{mm}$ (0.4 $\mu\text{m}/100\text{mm}$ )] ( ) : at the protruded detector position *with the X axis in horizontal orientation
Linear displacement accuracy (at 20°C):	$\pm(32+10L)\mu\text{in}$ ( $\pm(0.8+0.01L)\mu\text{m}$ ) * L = Drive length (mm)
Inclination range:	$\pm 45^\circ$
<b>Z2-axis (column)</b>	
Vertical travel:	12" (300mm)
Resolution:	39.4 $\mu\text{in}$ (1 $\mu\text{m}$ )
Measurement method:	ABSOLUTE linear encoder
Drive speed:	0 - .78"/s (0 - 20mm/s) and manual
<b>Z1-axis (detector unit)</b>	
Measuring resolution / range:	3 $\mu\text{in}/.2"$ , .3 $\mu\text{in}/.02"$ , .03 $\mu\text{in}/.002"$ (0.08 $\mu\text{m}/5\text{mm}$ , 0.008 $\mu\text{m}/0.5\text{mm}$ , 0.0008 $\mu\text{m}/0.05\text{mm}$ )
Measurement method:	Differential inductance method
Linear displacement:	$\pm(60+20H)\mu\text{in}$ ( $\pm(1.5+2H/100)\mu\text{m}$ )
Accuracy (at 20°C):	*H: Measurement height from the horizontal position (mm)
Stylus up/down operation:	Arc movement
Face of stylus:	Downward
Measuring force:	0.75mN
Traceable angle:	Ascent: 65°, descent: 65° (using the standard stylus provided and depending on the surface roughness)
Stylus tip:	Radius: 2 $\mu\text{m}$ , diamond
Base size (W x H):	23.6 x 17.7" (600 x 450mm)
Base material:	Granite
Mass:	309 lbs (140kg) (main unit)
Power supply:	100 - 240VAC $\pm 10\%$ , 50/60Hz
Power consumption:	400W (main unit only)

## Protrusion of Detector Position

**Normal detector position** Unit: mm

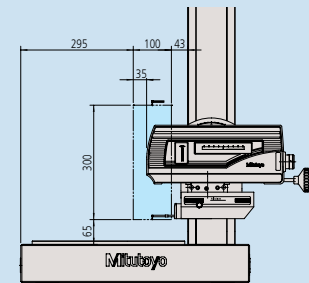

**When detector is maximally extended (Extended by 70mm from normal position)**

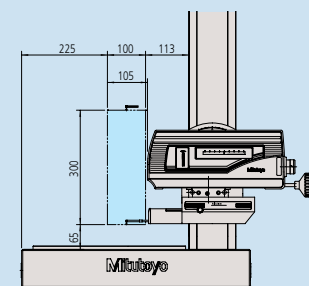

# Formtracer CS-3200

## SERIES 525 — Form Measuring Instruments

**MiCAT**

Mitutoyo Intelligent Computer Aided Technology

the standard in world  
metrology software  
**FORM**

### Software

#### FORMTRACEPAK6000

Enables control of the optional motor-driven Y-axis table and rotary table for realizing efficient measurement automation. You can also perform contour evaluation that allows free analysis of level differences, angle, pitch, area and other characteristics based on surface roughness data. In addition, you can create an original inspection certificate by setting the print format to suit your particular requirements.

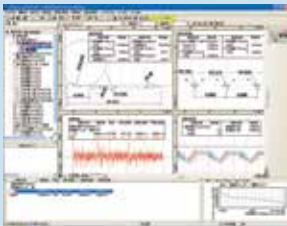

Measuring instrument control

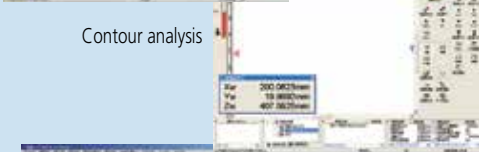

Contour analysis

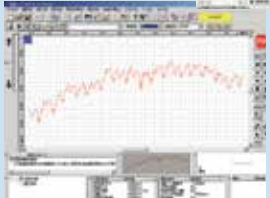

Surface roughness analysis

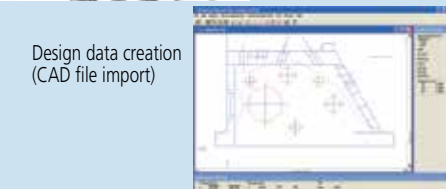

Design data creation  
(CAD file import)

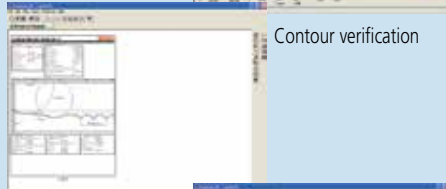

Contour verification

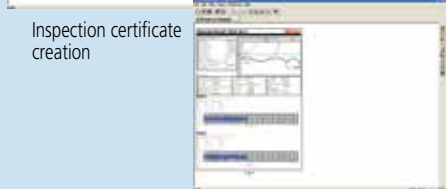

Inspection certificate creation

#### Main Unit Startup System

This machine incorporates a startup system (relocation detection system), which disables operation when an unexpected vibration is applied or the machine is relocated. Be sure to contact your nearest Mitutoyo prior to relocating this machine after initial installation.

### SPECIFICATIONS

Model No.	CS-3200S4
Order No. (inch)	525-411A
X1-axis measuring range	4" (100mm)
Z2-axis vertical travel	12" (300mm)

### Stylus

(Unit: inch (mm))

#### Standard stylus: No. 12AAD554

Tip radius: 2 μm  
Tip angle: 60° cone  
Tip material: Diamond

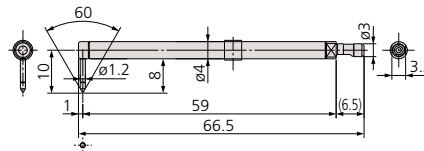

For contour/surface roughness measurement  
Measurable depth: .28" (7mm) max.

#### Eccentric stylus: No. 12AAD558

Tip radius: 2 μm  
Tip angle: 60° cone  
Tip material: Diamond

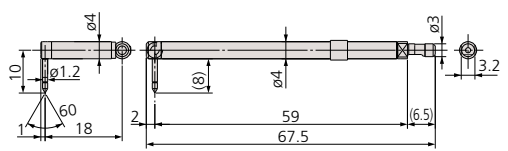

For contour/surface roughness measurement  
Measurable offset length: .60" (15mm)

#### Cone stylus: No. 12AAD552

Tip radius: 25 μm  
Tip angle: 30° cone  
Tip material: Sapphire

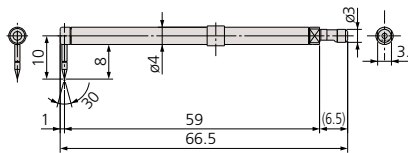

For contour measurement  
Measurable depth: .28" (7mm) max.

#### Deep Groove stylus: No. 12AAD560

Tip radius: 2 μm  
Tip angle: 60° cone  
Tip material: Diamond

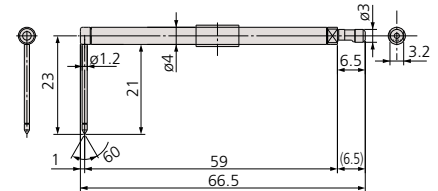

For contour/surface roughness measurement  
Measurable depth: .79" (20mm) max.

#### Small hole stylus: No. 12AAD556

Tip radius: 2 μm  
Tip angle: 60° cone  
Tip material: Diamond

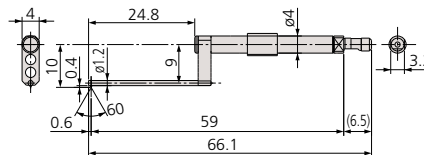

For contour/surface roughness measurement  
Applicable hole: ø.08" (ø2mm) min.

#### 2x-long stylus: No. 12AAD562

Tip radius: 5 μm  
Tip angle: 40° cone  
Tip material: Diamond

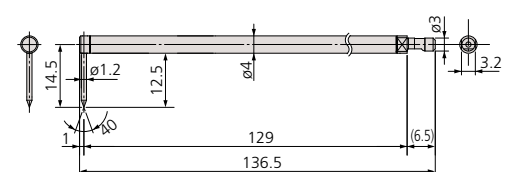

For contour/surface roughness measurement  
Measurable depth: .39" (10mm) max.

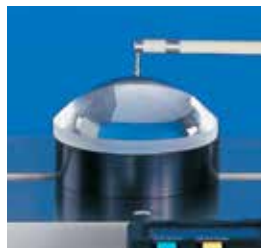

Measuring lens



Measuring ball screw



Measuring bearing ring

# Formtracer Extreme CS-5000CNC / CS-H5000CNC

## SERIES 525 — CNC Form Measuring Instruments



CS-H5000CNC with personal computer system and software

\* PC stand not included



Remote box



Wide range detector employing active control technology



### FEATURES

- High-accuracy stylus-type CNC surface measuring instrument allows simultaneous measurement of surface roughness and form/contour.
- The X1 axis has a maximum drive speed of 1.57"/s (40 mm/s) and Z2 axis has a maximum drive speed of 7.87"/s (200 mm/s). This permits high-speed positioning that may result in a large increase in the throughput of multiple-profile / multiple-workpiece measurement tasks.
- A Mitutoyo Laser Holescale is incorporated in the X1 axis and Z1 axis so that high resolution (X1 axis: 6.25nm, Z1 axis: 4nm/8nm) is achieved and batch measurement of form / contour and surface roughness can be made.
- The active control method is employed for the Z1-axis detector to implement a wide-range measurement capability wherein the variation in dynamic measuring force is restricted.
- Since the Z1-axis detector incorporates an anti-collision safety device, the detector unit will automatically stop even if its main body collides with a workpiece or fixture.
- For models with the  $\alpha$ -axis, it is possible to perform continuous measurement over horizontal and inclined surfaces by power-tilting the X1 axis.
- For models with the Y-axis table, it is possible to expand the measuring range for multiple workpieces, etc., through positioning in the Y-axis direction.
- Supplied with the easy-to-operate Remote Box, the user can make any movement by selecting the required axis using the two joysticks. The current axis selection is easily identified by the icon on the key top.
- Uses USB for communicating with the Data Processing / Analysis Unit (optional).

### Technical Data:

<b>X1 axis</b>	
Measuring range:	8" (200mm)
Resolution:	0.25 $\mu$ m (0.00625 $\mu$ m)
Measurement method:	Laser Holescale
Drive speed:	Max. 1.57"/s (40mm/s) (in CNC mode) 0 - 1.57"/s (0 - 40mm/s) (in joystick control mode)
Measuring speed:	.0008 - .008"/s (0.02 - 0.2mm/s) (surface roughness) .0008 - .08"/s (0.02 - 2mm/s) (form/contour)
Measuring direction:	Forward / Backward
Traverse linearity:	(4+1.5L) $\mu$ m {(0.1+0.0015L) $\mu$ m} with standard stylus (8+1.5L) $\mu$ m {(0.2+0.0015L) $\mu$ m} with 2X-long stylus
*Traverse linearity:	(2+3L) $\mu$ m {(0.05+0.0003L) $\mu$ m} with standard stylus (4+1.5L) $\mu$ m {(0.1+0.0015L) $\mu$ m} with 2X-long stylus
Linear displacement accuracy $\pm(20^{\circ}\text{C})$ :	$\pm(12+2L)\mu$ m { $\pm(0.3+0.002L)\mu$ m}
*Linear displacement accuracy $\pm(20^{\circ}\text{C})$ :	$\pm(2.8+6.3+L)\mu$ m { $\pm(0.16+0.001L)\mu$ m}
	L = Measured length inch (mm)
<b>Z1 axis</b>	
Measuring range:	.47" (12mm) (with standard stylus) .94" (24mm) (with 2X-long stylus)
Resolution:	.16 $\mu$ m (0.004 $\mu$ m) (with standard stylus) .32 $\mu$ m (0.008 $\mu$ m) (with 2X-long stylus)
*Resolution:	.03 $\mu$ m (0.0008 $\mu$ m) (with standard stylus) .06 $\mu$ m (0.0016 $\mu$ m) (with 2X-long stylus)
Stylus up/down:	Arc movement
Measurement method:	Transmission-type laser linear encoder
Linear displacement accuracy (20 $^{\circ}$ C):	$\pm(12+120H)\mu$ m { $\pm(0.3+10.02H)\mu$ m}
*Linear displacement accuracy (20 $^{\circ}$ C):	$\pm(2.8+120H)\mu$ m { $\pm(0.07+10.02H)\mu$ m}
	H = Measured height inch (mm)
Measuring force:	4mN (with standard stylus) 0.75mN (with 2X-long stylus)
Traceable angle:	60 $^{\circ}$ for ascent, 60 $^{\circ}$ for descent (Depending on the workpiece surface condition)
Stylus tip:	Radius: 5 $\mu$ m, angle: 40 $^{\circ}$ , diamond
(ball stylus)	(Radius: 0.25mm, sapphire)
Face of stylus:	Downward
<b>Z2 axis (column type)</b>	
Measuring range:	12" (300mm) (20" (500mm) high column type)
Resolution:	1.97 $\mu$ m (0.05 $\mu$ m)
Measurement method:	Reflective-type linear encoder
Drive speed:	Max. 7.87"/s (200mm/s) (in CNC mode) 0 - 1.97"/s (0 - 50mm/s) (in joystick control mode)
Base size (W x D):	29.5 x 23.6" (750 x 600mm)
Base material:	Granite
Dimension (W x D x H):	31.5 x 24.4 x 39.4" (800 x 620 x 1000mm) 31.5 x 24.4 x 47.2" (800 x 620 x 1200mm: high column type)
Mass:	529 lbs (240kg) 551 lbs (250kg): high column type)

\*CS-H5000CNC model in red.

# Formtracer Extreme CS-5000CNC / CS-H5000CNC

## SERIES 525 — CNC Form Measuring Instruments

### SPECIFICATIONS

Model No.	CS-5000CNC	CS-5000CNC
Order No. (100V - 120V)	<b>525-727-13</b>	<b>525-729-13</b>
X1-axis measuring range	8" (200mm)	8" (200mm)
Z2-axis vertical travel	12" (300mm)	12" (300mm)
Y-axis table unit	—	Installed
α-axis unit	Installed	Installed

Model No.	CS-5000CNC	CS-5000CNC
Order No. (100V - 120V)	<b>525-747-13</b>	<b>525-749-13</b>
X1-axis measuring range	8" (200mm)	8" (200mm)
Z2-axis vertical travel	20" (500mm)	20" (500mm)
Y-axis table unit	—	Installed
α-axis unit	Installed	Installed

Model No.	CS-H5000CNC	CS-H5000CNC	CS-H5000HCNC	CS-H5000HCNC
Order No. (100V - 120V)	<b>525-776-13</b>	<b>525-777-13</b>	<b>525-706-13</b>	<b>525-707-13</b>
X1-axis measuring range	8" (200mm)	8" (200mm)	8" (200mm)	8" (200mm)
Z2-axis vertical travel	12" (300mm)	12" (300mm)	20" (500mm)	20" (500mm)
Y-axis table unit	—	Installed	—	Installed

### Stylus

**12AAD543\*1:** Standard-length stylus (tip radius: 5μm)

**12AAJ037\*2:** For CS-H5000CNC (tip radius: 5μm)

Tip material: Diamond

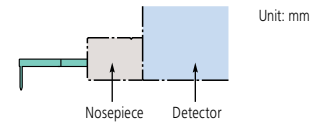
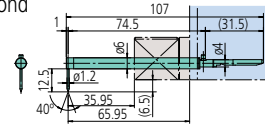

**12AAD544\*1\*2:** Standard-length ball stylus (tip radius: 5μm)

Tip material: Sapphire

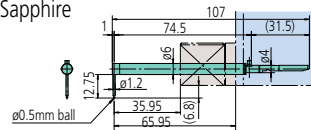

**12AAD651:** Standard-length stylus for small hole

Tip radius: 5μm

Tip material: Diamond

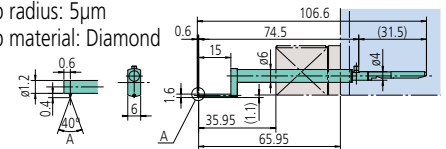

**12AAD652:** Standard-length stylus for extra-small hole

Tip radius: 5μm

Tip material: Diamond

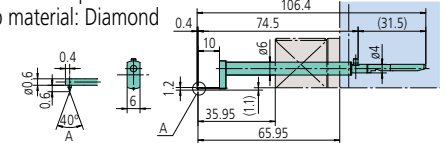

**12AAD653:** Standard-length eccentric stylus

Tip radius: 5μm

Tip material: Diamond

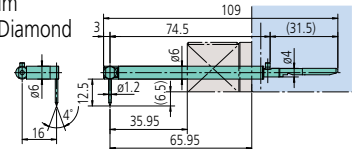

**12AAD545\*1:** Double-length stylus (tip radius: 5μm)

**12AAJ039\*2:** For CS-H5000CNC (tip radius: 5μm)

Tip material: Diamond

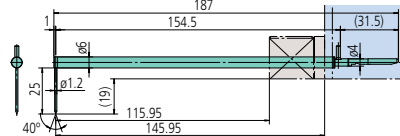

**12AAD546\*1\*2:** Double-length ball stylus

Tip material: Sapphire

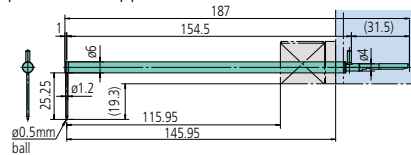

**12AAJ041\*2:** Double-length stylus (tip radius: 2μm)

Tip material: Diamond

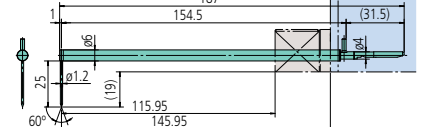

\*1: Standard accessory of CS-5000CNC

\*2: Standard accessory of CS-H5000CNC

### Software

#### FORMTRACEPAK V5

Enables control of the optional motor-driven Y-axis table and rotary table for realizing efficient measurement automation. You can also perform contour evaluation that allows free analysis of level differences, angle, pitch, area and other characteristics based on surface roughness data. In addition, analysis results can be saved in the "html", "mhtml" or pdf format which allows Internet Explorer or MS-Word compatibility, allowing PC without layout editing programs to view analysis results.

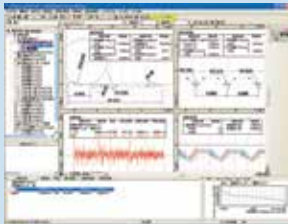

Contour Measurement and Surface Roughness Measurement Screen

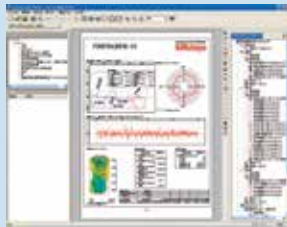

Report Layout Screen

#### ASLPAK (optional software)

Spherical lens analysis program recommended to be used with CS-H5000CNC and CS-5000CNC models. To make full use of software functions, optional accessories such as y-axis table, 3DALT and theta θ-1 table are required. The functions can be restricted without the optional accessories.

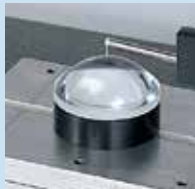

# Optional Styli for Surface Roughness Measurement

Compatible with SJ-410, SJ-500, SV-2100, SV-3100, SV-3000CNC, SV-M3000CNC, SV-C3200, SV-C4500 Series

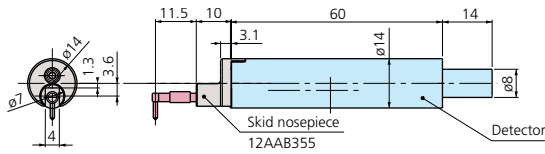

Detector (0.75mN): **178-396-2**  
 Detector (4mN): **178-397-2**

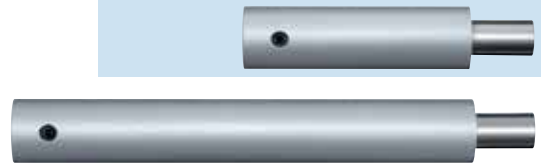

Extension rods  
 (12AAG202: 50mm, 12AAG203: 100mm)

## Styli

Unit: mm

### Standard stylus

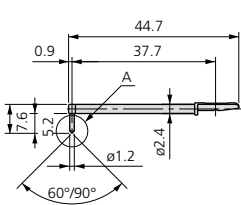
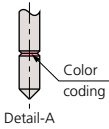

**12AAE882** (1µm)\*  
**12AAE924** (1µm)\*\*  
**12AAC731** (2µm)\*  
**12AAB331** (2µm)\*\*  
**12AAB403** (5µm)\*\*  
**12AAB415** (10µm)\*\*  
**12AAE883** (250µm)  
 ( ) : Tip radius  
 \*Tip angle: 60° \*\*Tip angle: 90°

### 2X long for deep hole

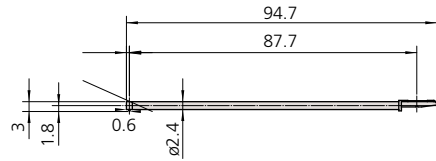

**12AAE898** (2µm)\*  
**12AAE914** (5µm)\*\*  
 ( ) : Tip radius  
 \*Tip angle: 60° \*\*Tip angle: 90°

### For small hole

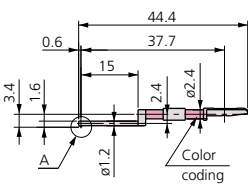
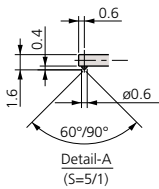

**12AAC732** (2µm)\*  
**12AAB404** (5µm)\*\*  
**12AAB416** (10µm)\*\*  
 ( ) : Tip radius  
 \*Tip angle: 60° \*\*Tip angle: 90°

### For small hole/2X long for deep hole

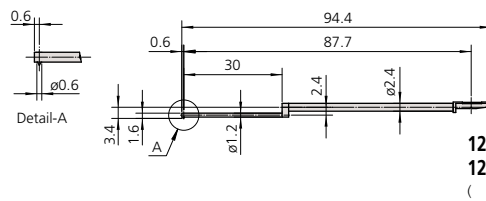

**12AAE892** (2µm)\*  
**12AAE908** (5µm)\*\*  
 ( ) : Tip radius  
 \*Tip angle: 60° \*\*Tip angle: 90°

### For extra-small hole

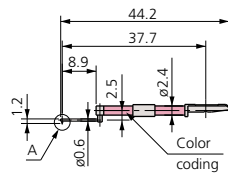
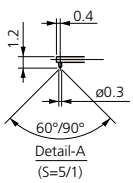

**12AAC733** (2µm)\*  
**12AAB405** (5µm)\*\*  
**12AAB417** (10µm)\*\*  
 ( ) : Tip radius  
 \*Tip angle: 60° \*\*Tip angle: 90°

### For small hole<sup>\*2</sup>

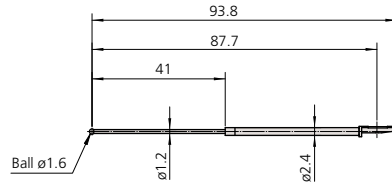

**12AAE884** (0.8mm)  
 ( ) : Tip radius

### For extra-minute hole

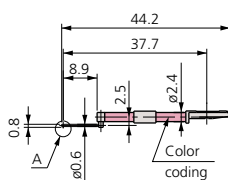
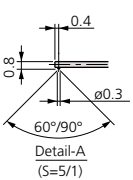

**12AAC734** (2µm)\*  
**12AAB406** (5µm)\*\*  
**12AAB418** (10µm)\*\*  
 ( ) : Tip radius  
 \*Tip angle: 60° \*\*Tip angle: 90°

### For ultra-small hole<sup>\*1\*2</sup>

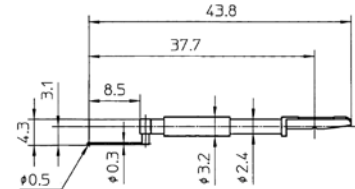

**12AAJ662** (0.25mm)  
 ( ) : Tip radius

### For deep hole (2X long and 3X long)

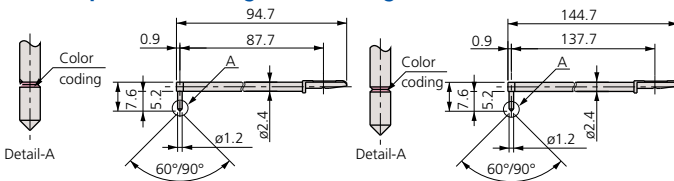

2X stylus  
**12AAC740** (2µm)\*  
**12AAB413** (5µm)\*\*  
**12AAB425** (10µm)\*\*  
 ( ) : Tip radius  
 \*Tip angle: 60° \*\*Tip angle: 90°

3X stylus  
**12AAC741** (2µm)\*  
**12AAB414** (5µm)\*\*  
**12AAB426** (10µm)\*\*  
 ( ) : Tip radius  
 \*Tip angle: 60° \*\*Tip angle: 90°

### For small-slotted hole

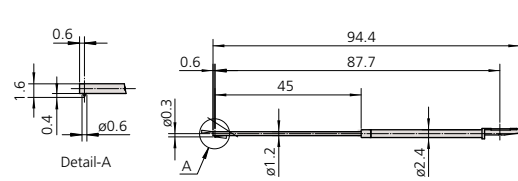

**12AAE938** (2µm)\*  
**12AAE940** (5µm)\*\*  
 ( ) : Tip radius  
 \*Tip angle: 60° \*\*Tip angle: 90°

\*1: For downward-facing measurement only

\*2: Used for calibration, a standard step gauge (No.178-611, option) is also required.

Tip radius	1µm	2µm	5µm	10µm	250µm
Color coding	White	Black	No color	Yellow	No notch or color

# Optional Styli for Surface Roughness Measurement

Compatible with SJ-410, SJ-500, SV-2100, SV-3200, SV-3000CNC,  
SV-M3000CNC, SV-C3200, SV-C4500 Series

## Styli

Unit: mm

### For deep groove (10mm)

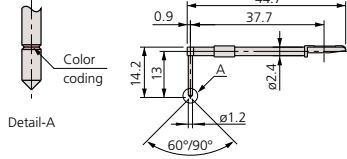

**12AAC735** (2μm)\*  
**12AAB409** (5μm)\*\*  
**12AAB421** (10μm)\*\*  
( ) : Tip radius  
\*Tip angle: 60° \*\*Tip angle: 90°

### For deep groove (20mm)<sup>\*1</sup>/2X Long for deep hole

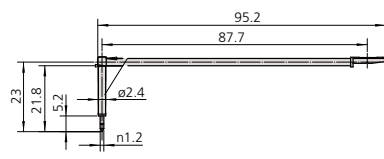

**12AAE893** (2μm)\*  
**12AAE909** (5μm)\*\*  
( ) : Tip radius  
\*Tip angle: 60° \*\*Tip angle: 90°

### For deep groove (20mm)

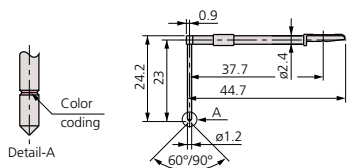

**12AAC736** (2μm)\*  
**12AAB408** (5μm)\*\*  
**12AAB420** (10μm)\*\*  
( ) : Tip radius  
\*Tip angle: 60° \*\*Tip angle: 90°

### For deep groove (40mm)<sup>\*1</sup>

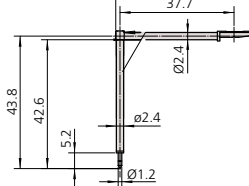

**12AAE895** (2μm)\*  
**12AAE911** (5μm)\*\*  
( ) : Tip radius  
\*Tip angle: 60° \*\*Tip angle: 90°

### For deep groove (30mm)

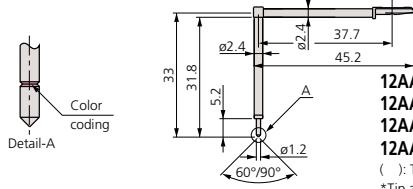

**12AAC737** (2μm)\*  
**12AAB335** (2μm)\*\*  
**12AAB407** (5μm)\*\*  
**12AAB419** (10μm)\*\*  
( ) : Tip radius  
\*Tip angle: 60° \*\*Tip angle: 90°

### For deep groove (30mm)<sup>\*1</sup>/2X Long for deep hole

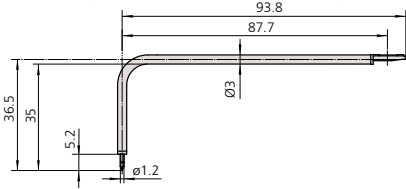

**12AAE894** (2μm)\*  
**12AAE910** (5μm)\*\*  
( ) : Tip radius  
\*Tip angle: 60° \*\*Tip angle: 90°

### For gear tooth

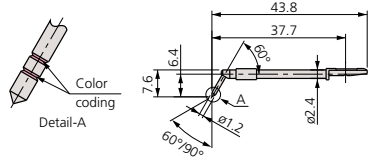

**12AAB339** (2μm)\*  
**12AAB410** (5μm)\*\*  
**12AAB422** (10μm)\*\*  
( ) : Tip radius  
\*Tip angle: 60° \*\*Tip angle: 90°

### For gear tooth<sup>\*1</sup>/2X Long for deep hole

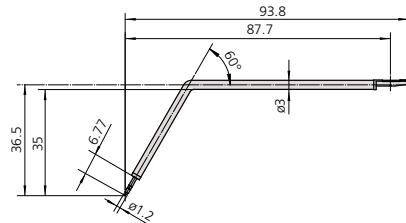

**12AAE896** (2μm)\*  
**12AAE912** (5μm)\*\*  
( ) : Tip radius  
\*Tip angle: 60° \*\*Tip angle: 90°

### For rolling circle waviness surface<sup>\*2</sup>

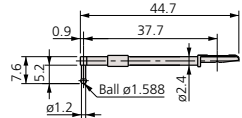

**12AAB338** (0.8mm)  
( ) : Tip radius

### For rolling circle waviness<sup>\*1</sup>/2X Long for deep hole<sup>\*2</sup>

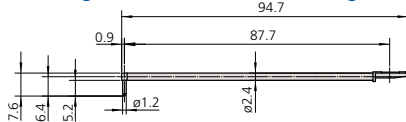

**12AAE886** (0.25mm)  
( ) : Tip radius

### For knife-edge detector

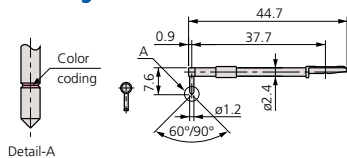

**12AAC738** (2μm)\*  
**12AAB411** (5μm)\*\*  
**12AAB423** (10μm)\*\*  
( ) : Tip radius  
\*Tip angle: 60° \*\*Tip angle: 90°

### For corner hole<sup>\*1</sup>/2X Long for deep hole

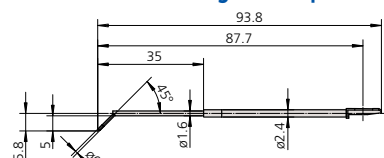

**12AAM601** (2μm)\*  
**12AAM603** (5μm)\*\*  
( ) : Tip radius  
\*Tip angle: 60° \*\*Tip angle: 90°

### For eccentric arm<sup>\*1</sup>

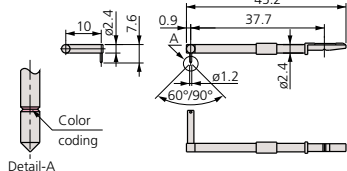

**12AAC739** (2μm)\*  
**12AAB412** (5μm)\*\*  
**12AAB424** (10μm)\*\*  
( ) : Tip radius  
\*Tip angle: 60° \*\*Tip angle: 90°

### For bottom surface

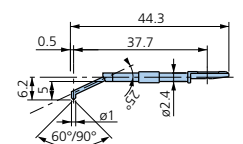

**12AAE899** (2μm)\*  
**12AAE915** (5μm)\*\*  
( ) : Tip radius  
\*Tip angle: 60° \*\*Tip angle: 90°

Tip radius	1μm	2μm	5μm	10μm	250μm
Color coding	White	Black	No color	Yellow	No notch or color

\*1: For downward-facing measurement only

\*2: Used for calibration, a standard step gauge (No.178-611, option) is also required.

# Optional Accessories for Automatic Measurement

Compatible with SV-3200, SV-C3200, SV-C4500, CS-3200 and CNC Models

## Y-axis table\*: 178-097

A Y-axis table for both positioning and capable of 3D surface roughness measurement when used with optional software FTPK-PRO or MCubeMap.\*\*  
\* Not supporting Y-axis measurements. \*\* Only for 178-096



	178-097	178-096
Travel range	8" (200mm)	4" (100mm)
Resolution	1.97µm (0.05µm)	1.97µm (0.05µm)
Positioning accuracy	±3µm	±1µm
Drive speed	Max. 3.15"/s (80mm/s)	Max. .78"/s (20mm/s)
Maximum load	110 lbs (50kg)	33 lbs (50kg)
Mass	62 lbs (28kg)	68 lbs (31kg)

## θ2-axis table: 178-078\*

You can measure multiple points on a cylindrical workpiece and automate front/rear-side measurement.

\* θ2-axis mounting plate (12AAE718) is required when directly installing on the base of the SV-3100.

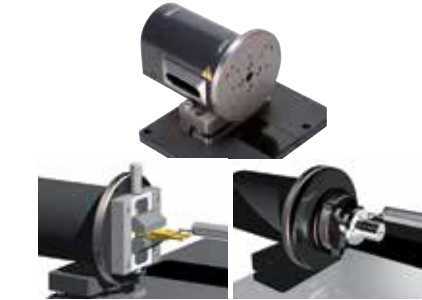

Displacement	360°
Resolution	0.0072°
Maximum load (loading moment)	8.8 lbs (4kg) (343 N·cm or less)
Rotational speed	Max. 18°/s
Mass	11 lbs (5kg)

## Quick chuck: 211-032

This chuck is useful when measuring small workpieces. You can easily clamp them with its knurled ring.



Retention range	Inner latch	OD: ø.04 - 1.42" (1 - 36mm)
	Inner latch	ID: ø.55 - 2.76" (14 - 70mm)
	Outer latch	OD: ø.04 - 2.95" (1 - 75mm)
Dimensions	ø 4.65 x 1.61" (118 x 41mm)	
Mass	2.6 lbs (1.2kg)	

## θ1-axis table: 12AAD975\*

For efficient measurement in the axial/transverse directions. When measuring a cylindrical workpiece, automatic alignment can be performed in combination with the Y-axis table.

\* θ1-axis mounting plate (12AAE630) is required when directly installing on the base of the SV-3100.

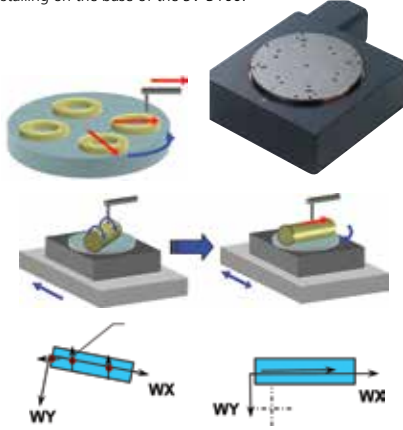

Displacement	360°
Resolution	0.004°
Maximum load	26.5 lbs (12kg)
Rotational speed	Max. 10°/s
Mass	15 lbs (7kg)

## Auto-leveling table: 178-087

This is a stage that performs fully automatic leveling as measurement starts, freeing the user from this troublesome operation. Fully automatic leveling can be done quickly by anyone. In addition, the operation is easy and reliable.



Inclination adjustment angle	±2°
Maximum load	15 lbs (7kg)
Table dimensions	5.1 x 3.9" (130 x 100mm)
Mass	7.7 lbs (3.5kg)

## Micro-chuck: 211-031

This chuck is suitable for clamping extra-small diameter workpieces (ø1mm or less), which cannot be retained with the centering chuck.



Retention range	OD: ø 0 - .06" (0 - 1.5mm)
Dimensions	ø 4.65 x 1.9" (118 x 48.5mm)
Mass	1.3 lbs (0.6kg)

## Examples of optimal combinations of accessories for CNC models

Optional accessory \ Function	Y-axis Table	θ1 Table	θ2 Table
Automatic leveling	—	—	—
Automatic alignment (Patent registered: Japan)	●	●	—
Multiple workpiece batch measurement	▲	—	—
Measurement in the Y-axis direction	●	—	—
Oblique measurement of XY plane **	●	—	—
Outside 3D surface roughness measurement/evaluation **	●	—	—
Multiple-piece measurement in the Y-axis direction (Positioning in the Y-axis direction)	●	—	—
Multiple-piece measurement in the radius direction (Positioning in the rotating direction of XY plane)	▲	●	—
Tracking measurement in the Z-axis direction *	—	—	—
Inclined surface measurement in the X-axis direction	▲	—	—
Inclined hole inside measurement in the X-axis direction	▲	—	—
Multiple cylinder generatrix line measurement	▲	—	●
Measurement of both top and bottom surfaces	▲	—	●
Rotary positioning of large workpiece ***	—	—	—
Upward/downward and frontward/backward measurement of large workpiece ***	—	—	—

\* : Applicable only to form/contour measurement

\*\* : Applicable only to surface roughness measurement

\*\*\* : Applicable only for SV-M3000CNC

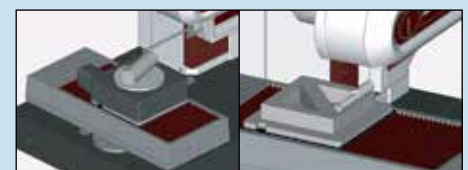
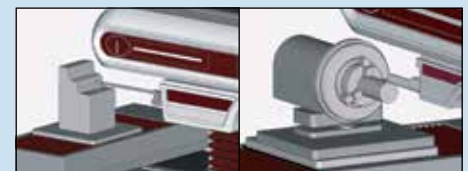
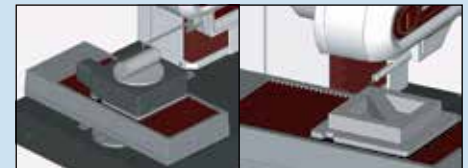





# Quick Guide to Precision Measuring Instruments

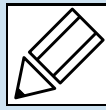

## Surftest (Surface Roughness Testers)

- JIS B 0601: 2001 Geometric Product Specifications (GPS)–Surface Texture: Profile method– Terms, definitions, and surface texture parameters
- JIS B 0632: 2001 Geometric Product Specifications (GPS)–Surface Texture: Profile method– Metrological characterization of phase-correct filters
- JIS B 0633: 2001 Geometric Product Specifications (GPS)–Surface Texture: Profile method– Rules and procedures for the assessment of surface texture
- JIS B 0651: 2001 Geometric Product Specifications (GPS)–Surface Texture: Profile method– Nominal characteristics of contact (stylus) instruments

### Nominal Characteristics of Contact (Stylus) Instruments

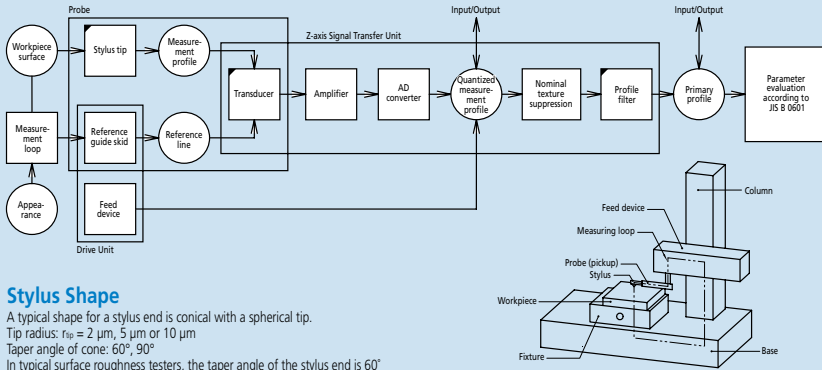

### Stylus Shape

A typical shape for a stylus end is conical with a spherical tip.  
 Tip radius:  $r_{tp} = 2 \mu\text{m}, 5 \mu\text{m}$  or  $10 \mu\text{m}$   
 Taper angle of cone:  $60^\circ, 90^\circ$   
 In typical surface roughness testers, the taper angle of the stylus end is  $60^\circ$  unless otherwise specified.

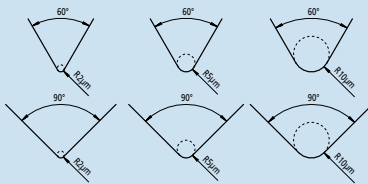

### Static Measuring Force

Nominal radius of curvature of stylus tip: $\mu\text{m}$	Static measuring force at the mean position of stylus: mN	Tolerance on static measuring force variations: mN/ $\mu\text{m}$
2	0.75	0.035
5	0.75 (4.0) Note 1	0.2
10		

Note 1: The maximum value of static measuring force at the average position of a stylus is to be  $4.0 \text{mN}$  for a special structured probe including a replaceable stylus.

### Relationship between Cutoff Value and Stylus Tip Radius

The following table lists the relationship between the roughness profile cutoff value  $\lambda_c$ , stylus tip radius  $r_{tp}$ , and cutoff ratio  $\lambda_c/\lambda_s$ .

$\lambda_c$ mm	$\lambda_s$ $\mu\text{m}$	$\lambda_c/\lambda_s$	Maximum $r_{tp}$ $\mu\text{m}$	Maximum sampling length $\mu\text{m}$
0.08	2.5	30	2	0.5
0.25	2.5	100	2	0.5
0.8	2.5	300	2 Note 1	0.5
2.5	8	300	5 Note 2	1.5
8	25	300	10 Note 2	5

Note 1: For a surface with  $Ra > 0.5 \mu\text{m}$  or  $Rz > 3 \mu\text{m}$ , a significant error will not usually occur in a measurement even if  $r_{tp} = 5 \mu\text{m}$ .  
 Note 2: If a cutoff value  $\lambda_c$  is  $\geq 2.5 \text{mm}$  or  $8 \text{mm}$ , attenuation of the signal due to the mechanical filtering effect of a stylus with the recommended tip radius appears outside the roughness profile pass band. Therefore, a small error in stylus tip radius or shape does not affect parameter values calculated from measurements. If a specific cutoff ratio is required, the ratio must be defined.

### Metrological Characterization of Phase Correct Filters

A profile filter is a phase-correct filter without phase delay (cause of profile distortion dependent on wavelength). The weight function of a phase-correct filter shows a normal (Gaussian) distribution in which the amplitude transmission is 50% at the cutoff wavelength.

JIS B 0632: 2001 (ISO 11562: 1996)

### Surface Profiles

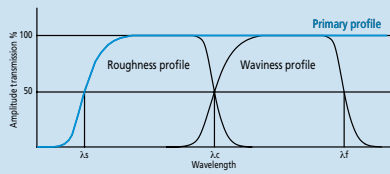

### Primary Profile

Profile obtained from the measured profile by applying a low-pass filter with cutoff value  $\lambda_s$ .

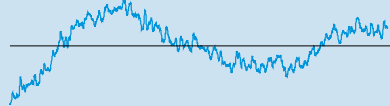

### Roughness Profile

Profile obtained from the primary profile by suppressing the longer wavelength components using a high-pass filter of cutoff value  $\lambda_c$ .



### Waviness Profile

Profile obtained by applying a band-pass filter to the primary profile to remove the longer wavelengths above  $\lambda_f$  and the shorter wavelengths below  $\lambda_c$ .

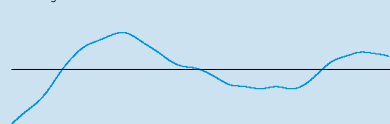

### Definition of Parameters

JIS B 0601: 2001 (ISO 4287: 1997)

#### Amplitude Parameters (peak and valley)

- Maximum peak height of the primary profile  $P_p$
- Maximum peak height of the roughness profile  $R_p$
- Maximum peak height of the waviness profile  $W_p$
- Largest profile peak height  $Z_p$  within a sampling length

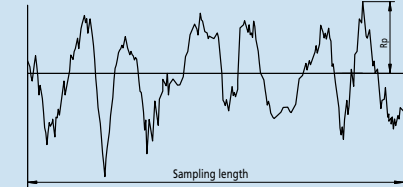

- Maximum valley depth of the primary profile  $P_v$
- Maximum valley depth of the roughness profile  $R_v$
- Maximum valley depth of the waviness profile  $W_v$
- Largest profile valley depth  $Z_v$  within a sampling length

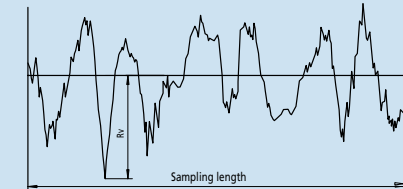

- Maximum height of the primary profile  $P_z$
- Maximum height of the roughness profile  $R_z$
- Maximum height of the waviness profile  $W_z$

Sum of height of the largest profile peak height  $Z_p$  and the largest profile valley depth  $Z_v$  within a sampling length

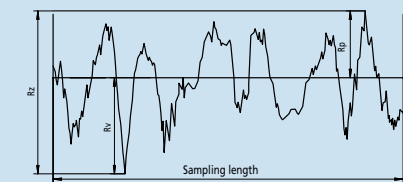

In Old JIS and ISO 4287-1: 1984,  $R_z$  was used to indicate the "ten point height of irregularities." Care must be taken because differences between results obtained according to the existing and old standards are not always negligibly small. (Be sure to check whether the drawing instructions conform to existing or old standards.)

- Mean height of the primary profile elements  $P_c$
- Mean height of the roughness profile elements  $R_c$
- Mean height of the waviness profile elements  $W_c$

Mean value of the profile element heights  $Z_t$  within a sampling length

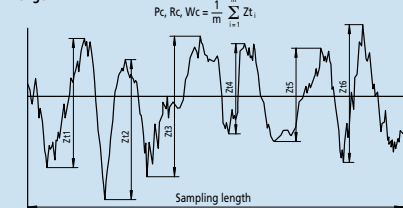

- Total height of the primary profile  $P_t$
- Total height of the roughness profile  $R_t$
- Total height of the waviness profile  $W_t$

Sum of the height of the largest profile peak height  $Z_p$  and the largest profile valley depth  $Z_v$  within the evaluation length

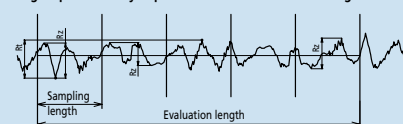

### Data Processing Flow

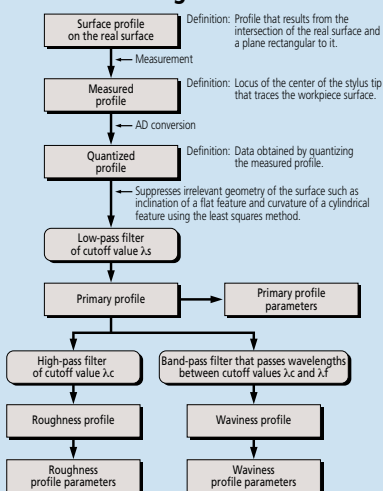

## Amplitude Parameters (average of ordinates)

Arithmetical mean deviation of the primary profile  $P_a$   
 Arithmetical mean deviation of the roughness profile  $R_a$   
 Arithmetical mean deviation of the waviness profile  $W_a$   
 Arithmetic mean of the absolute ordinate values  $Z(x)$  within a sampling length

$$P_a, R_a, W_a = \frac{1}{l} \int_0^l |Z(x)| dx$$

with  $l$  as  $l_p, l_r$  or  $l_w$  according to the case.

Root mean square deviation of the primary profile  $P_q$   
 Root mean square deviation of the roughness profile  $R_q$   
 Root mean square deviation of the waviness profile  $W_q$   
 Root mean square value of the ordinate values  $Z(x)$  within a sampling length

$$P_q, R_q, W_q = \sqrt{\frac{1}{l} \int_0^l Z^2(x) dx}$$

with  $l$  as  $l_p, l_r$  or  $l_w$  according to the case.

Skewness of the primary profile  $P_{sk}$   
 Skewness of the roughness profile  $R_{sk}$   
 Skewness of the waviness profile  $W_{sk}$

Quotient of the mean cube value of the ordinate values  $Z(x)$  and the cube of  $P_q, R_q$ , or  $W_q$ , respectively, within a sampling length

$$R_{sk} = \frac{1}{R_q^3} \left[ \frac{1}{l_r} \int_0^{l_r} Z^3(x) dx \right]$$

The above equation defines  $R_{sk}$ .  $P_{sk}$  and  $W_{sk}$  are defined in a similar manner.  $P_{sk}, R_{sk}$ , and  $W_{sk}$  are measures of the asymmetry of the probability density function of the ordinate values.

Kurtosis of the primary profile  $P_{ku}$   
 Kurtosis of the roughness profile  $R_{ku}$   
 Kurtosis of the waviness profile  $W_{ku}$

Quotient of the mean quartic value of the ordinate values  $Z(x)$  and the fourth power of  $P_q, R_q$ , or  $W_q$ , respectively, within a sampling length

$$R_{ku} = \frac{1}{R_q^4} \left[ \frac{1}{l_r} \int_0^{l_r} Z^4(x) dx \right]$$

The above equation defines  $R_{ku}$ .  $P_{ku}$  and  $W_{ku}$  are defined in a similar manner.  $P_{ku}, R_{ku}$ , and  $W_{ku}$  are measures of the sharpness of the probability density function of the ordinate values.

## Spacing Parameters

Mean width of the primary profile elements  $P_{sm}$   
 Mean width of the roughness profile elements  $R_{sm}$   
 Mean width of the waviness profile elements  $W_{sm}$

Mean value of the profile element widths  $X_s$  within a sampling length

$$P_{sm}, R_{sm}, W_{sm} = \frac{1}{m} \sum_{i=1}^m X_{s_i}$$

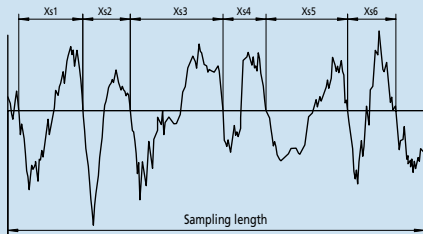

## Hybrid Parameters

Root mean square slope of the primary profile  $P_{\Delta q}$   
 Root mean square slope of the roughness profile  $R_{\Delta q}$   
 Root mean square slope of the waviness profile  $W_{\Delta q}$

Root mean square value of the ordinate slopes  $dZ/dX$  within a sampling length

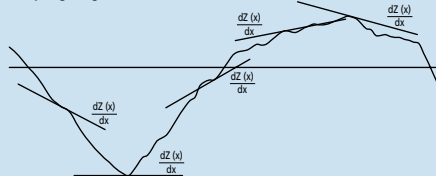

## Curves, Probability Density Function, and Related Parameters

Material ratio curve of the profile (Abbott-Firestone curve)

Curve representing the material ratio of the profile as a function of section level  $c$

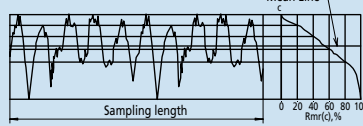

Material ratio of the primary profile  $P_{mr}(c)$   
 Material ratio of the roughness profile  $R_{mr}(c)$   
 Material ratio of the waviness profile  $W_{mr}(c)$

Ratio of the material length of the profile elements  $MI(c)$  at a given level  $c$  to the evaluation length

$$P_{mr}(c), R_{mr}(c), W_{mr}(c) = \frac{MI(c)}{l_n}$$

Section height difference of the primary profile  $P_{dc}$   
 Section height difference of the roughness profile  $R_{dc}$   
 Section height difference of the waviness profile  $W_{dc}$

Vertical distance between two section levels of a given material ratio

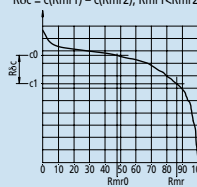

Relative material ratio of the primary profile  $P_{mr}$   
 Relative material ratio of the roughness profile  $R_{mr}$   
 Relative material ratio of the waviness profile  $W_{mr}$

Material ratio determined at a profile section level  $R_{\delta c}$  (or  $P_{\delta c}$  or  $W_{\delta c}$ ), related to the reference section level  $c_0$

$$P_{mr}, R_{mr}, W_{mr} = P_{mr}(c_1), R_{mr}(c_1), W_{mr}(c_1)$$

where  $c_1 = c_0 - R_{\delta c} / (R_{\delta c_0} / W_{\delta c_0})$   
 $c_0 = c(P_{m0}, R_{m0}, W_{m0})$

Probability density function (profile height amplitude distribution curve)

Sample probability density function of the ordinate  $Z(x)$  within the evaluation length

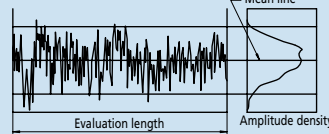

## JIS Specific Parameters

Ten-point height of irregularities,  $Rz_{15}$

Sum of the absolute mean height of the five highest profile peaks and the absolute mean depth of the five deepest profile valleys, measured from the mean line within the sampling length of a roughness profile. This profile is obtained from the primary profile using a phase-correct band-pass filter with cutoff values of  $f_c$  and  $f_s$ .

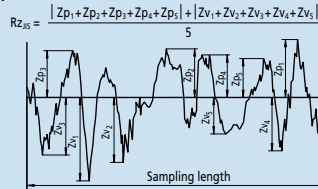

Symbol	Used profile
$Rz_{15S2}$	Surface profile as measured
$Rz_{15S4}$	Roughness profile derived from the primary profile using a phase-correct high-pass filter

Arithmetic mean deviation of the profile  $Ra_{15}$

Arithmetic mean of the absolute values of the profile deviations from the mean line within the sampling length of the roughness profile (75%). This profile is obtained from a measurement profile using an analog high-pass filter with an attenuation factor of 12db/octave and a cutoff value of  $f_c$ .

$$Ra_{15} = \frac{1}{l_n} \int_0^{l_n} |Z(x)| dx$$

## Sampling Length for Surface Roughness Parameters

JIS B 0633: 2001 (ISO 4288: 1996)

Table 1: Sampling lengths for aperiodic profile roughness parameters ( $R_a, R_q, R_{sk}, R_{ku}, R_{\Delta q}$ ), material ratio curve, probability density function, and related parameters

$R_a$ $\mu m$	Sampling length $l_r$ mm	Evaluation length $l_n$ mm
$(0.006) < R_a \leq 0.02$	0.08	0.4
$0.02 < R_a \leq 0.1$	0.25	1.25
$0.1 < R_a \leq 2$	0.8	4
$2 < R_a \leq 10$	2.5	12.5
$10 < R_a \leq 80$	8	40

Table 2: Sampling lengths for aperiodic profile roughness parameters ( $R_z, R_v, R_p, R_c, R_t$ )

$R_z$ $Rz1max$ $\mu m$	Sampling length $l_r$ mm	Evaluation length $l_n$ mm
$(0.025) < R_z, Rz1max \leq 0.1$	0.08	0.4
$0.1 < R_z, Rz1max \leq 0.5$	0.25	1.25
$0.5 < R_z, Rz1max \leq 10$	0.8	4
$10 < R_z, Rz1max \leq 50$	2.5	12.5
$50 < R_z, Rz1max \leq 200$	8	40

1)  $R_z$  is used for measurement of  $R_z, R_v, R_p, R_c$ , and  $R_t$ .  
 2)  $Rz1max$  only used for measurement of  $Rz1max, Rv1max, Rp1max$ , and  $Rt1max$ .

Table 3: Sampling lengths for measurement of periodic roughness profile roughness parameters and periodic or aperiodic profile parameter  $R_{sm}$

$R_{sm}$ mm	Sampling length $l_r$ mm	Evaluation length $l_n$ mm
$0.013 < R_{sm} \leq 0.04$	0.08	0.4
$0.04 < R_{sm} \leq 0.13$	0.25	1.25
$0.13 < R_{sm} \leq 0.4$	0.8	4
$0.4 < R_{sm} \leq 1.3$	2.5	12.5
$1.3 < R_{sm} \leq 4$	8	40

## Procedure for determining a sampling length if it is not specified

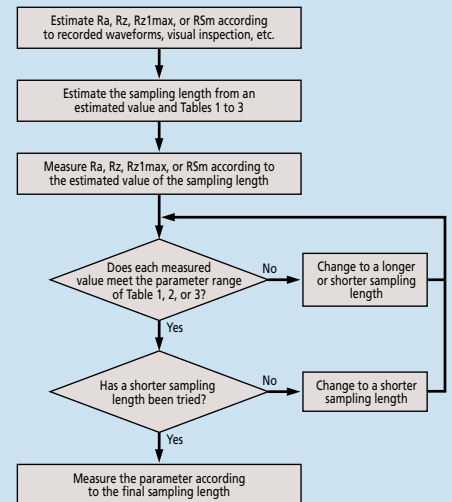

Table 1. Procedure for determining the sampling length of an aperiodic profile if it is not specified.

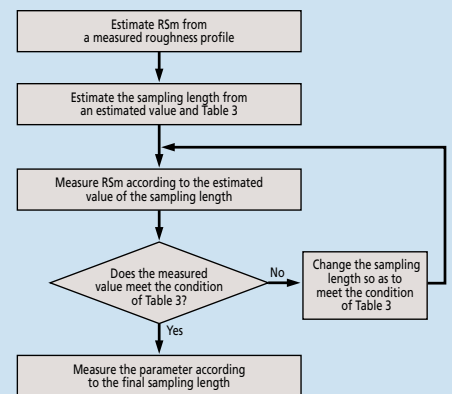

Table 2. Procedure for determining the sampling length of a periodic profile if it is not specified.

# Contracer CV-2100

## SERIES 218 — Contour Measuring Instruments

### FEATURES

- Newly designed high-precision digital ARC scale improves the Z-axis accuracy and resolution.
- Quick-release grip handle allows for rapid traverse in column Z-axis for CV-2100M4.
- Key operation buttons are now mounted onto the X-axis drive unit, eliminating wired remote box.
- X-axis traverse speed has been greatly improved to 20mm/s allowing quick positioning and set-up time.
- New added function for automatic stylus up/down means high-volume repetitive measurements are now capable with part programming.
- Z-axis detector measuring range has been improved to 50mm for both models.
- CV-2100N4 model can be mounted to optional manual column stand or custom fixture supplied by end user.

CV-2100M4 with personal computer system and software



Connected to a personal computer, the FORMTRACEPAK V5 contour analysis program provides various modes of measurement and analysis.  
\*Printer not included

### Technical Data

X1-axis	
Measuring range:	4" (100mm) (CV-2100)
Resolution:	3.93µin (0.1µm)
Measurement method:	STVC-10Z
Drive speed:	0-.79"/s (0-20mm/s)
Measuring speed:	.000787"/s, .2"/s (.02, 5mm/s)
Measuring direction:	Forward / Backward
Traverse linearity:	98.4µin/4" (2.5µm/100mm) (CV-2100)
Linear displacement:	±(100+20L)µin ±(2.5+2L/100)µm
	* L = Drive length (mm)
Inclining range:	±45°
Z2-axis (column)	
Column type:	Manual (M4 type)
Vertical travel:	13.8" (350mm) (M4 type)

### Z1-axis (detector unit)

Measuring range:	2" (50mm)
Resolution:	3.93µin (0.1µm)
Measurement method:	Digital arc scale
Linear displacement:	±(100+100h)µin ±(2.5+0.1H)µm
Accuracy (at 20°C):	*H: Measurement height from the horizontal position within ±1" (±25mm)

### Stylus up/down operation: Arc movement

Face of stylus:	Downward
Measuring force:	30±10mN (3gf)
Traceable angle:	Ascent: 77°, descent: 87° (using the standard stylus provided and depending on the surface roughness)

Stylus tip	Radius: 25µm, carbide tip
Base size (W x H):	23.6 x 17.7" (600 x 450mm)
Base material:	Granite
Mass:	321 lbs (145.8kg) (CV-2100M4),
Power supply:	100 – 240VAC ±10%, 50/60Hz
Power consumption:	30W (main unit only)



Centralized front control panel



Quick-vertical motion handle



X-axis jog shuttle

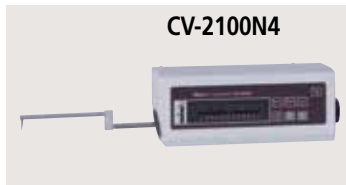

CV-2100N4

\*1



Desktop PC



Manual column stand for CV-2100N4\*2

### Highly accurate arc scale



This scale directly tracks the arc trajectory of the stylus tip so that the most accurate compensation can be applied to the scale output, which leads to higher accuracy and resolution.

\*1: If the CV-2100N4 is operated without the dedicated manual stand, the measuring range of the Z-axis might be reduced, depending on the installation conditions. If you are considering using the CV-2100N4 without the stand, contact your local Mitutoyo sales office for advice.

\*2: Optional accessory 218-042 manual column stand

# Contracer CV-2100

## SERIES 218 — Contour Measuring Instruments

### Optional Accessories

- 218-042:** Column stand for CV-2100N4  
(vertical travel: 250mm, inclination:  $\pm 45^\circ$ )
- 218-001:** Cross-travel table (XY range: 100 x 50mm)
- 218-011:** Cross-travel table (XY range: 4" x 2")
- 218-041:** Cross-travel table (XY range: 50 x 25mm)
- 218-051:** Cross-travel table (XY range: 2" x 1")
- 218-002:** Rugged table
- 176-107:** Holder with clamp
- 218-003:** Rotary vise (heavy-duty type)
- 172-144:** Rotary vise
- 172-234:** V-block with clamp  
(Max. workpiece dia.: 50mm)
- 172-378:** V-block with clamp  
(Max. workpiece dia.: 25mm)
- 172-197:** Swivel center support
- 172-142:** Center support
- 172-143:** Center support riser
- 998862:** Pin gage unit for calibration (mm)
- 998861:** Pin gage unit for calibration (inch)
- :** Arms and styli (See page J-32/33.)
- 12AAG175:** Calibration table
- 178-047:** 3-axis adjustment table

### SPECIFICATIONS

Model		CV-2100M4	CV-2100N4
Order No.		218-643A	218-623A
Measurement range	X-axis	4" (100mm)	
	Z1-axis (detector unit)	2" (50mm)	
Z2-axis (column) travel range		13.8" (350mm)	—
X-axis inclination angle		$\pm 45^\circ$	—
Resolution	X-axis	3.93 $\mu$ m (0.1 $\mu$ m)	
	Z1-axis	3.93 $\mu$ m (0.1 $\mu$ m)	
Drive method	X-axis	Motorized drive 0 - 0.79in/s (0 - 20mm/s)	
	Z2-axis (column)	Manual (quick up-and-down motion, fine feed)	—
Measuring speed		.00078 - .2"/sec (0.02 - 5mm/s)	
Linearity accuracy (X-axis horizontal orientation)		98.4 $\mu$ m/4in (2.5 $\mu$ m/100mm)	
Accuracy (20°C)	X-axis	$\pm(100+20L)\mu$ m [ $\pm(2.5+0.02L)\mu$ m] L = Measurement Length (mm)	
	Z1-axis	$\pm(100+ 100H )\mu$ m [ $\pm(2.5+ 0.1H )\mu$ m] H = Measurement height from horizontal position within 1" ( $\pm 25$ mm)	
Measurement direction		Forward / Backward	
Measurement surface direction		Downward	
Measuring force		(3gf) (30 $\pm$ 10mN)	
Stylus traceable angle (Standard accessory stylus)		Ascent 77°, Descent 87° (Depends on the surface condition)	
External dimensions (WxDxH)		29.3 x 17.7 x 34.8" (745x450x885mm)	25.6 x 5.63 x 5.45" (651x143x138.5mm)
Mass		321.43 lbs (145.8 kg)	12.78 lbs (5.8 kg)

### DIMENSIONS

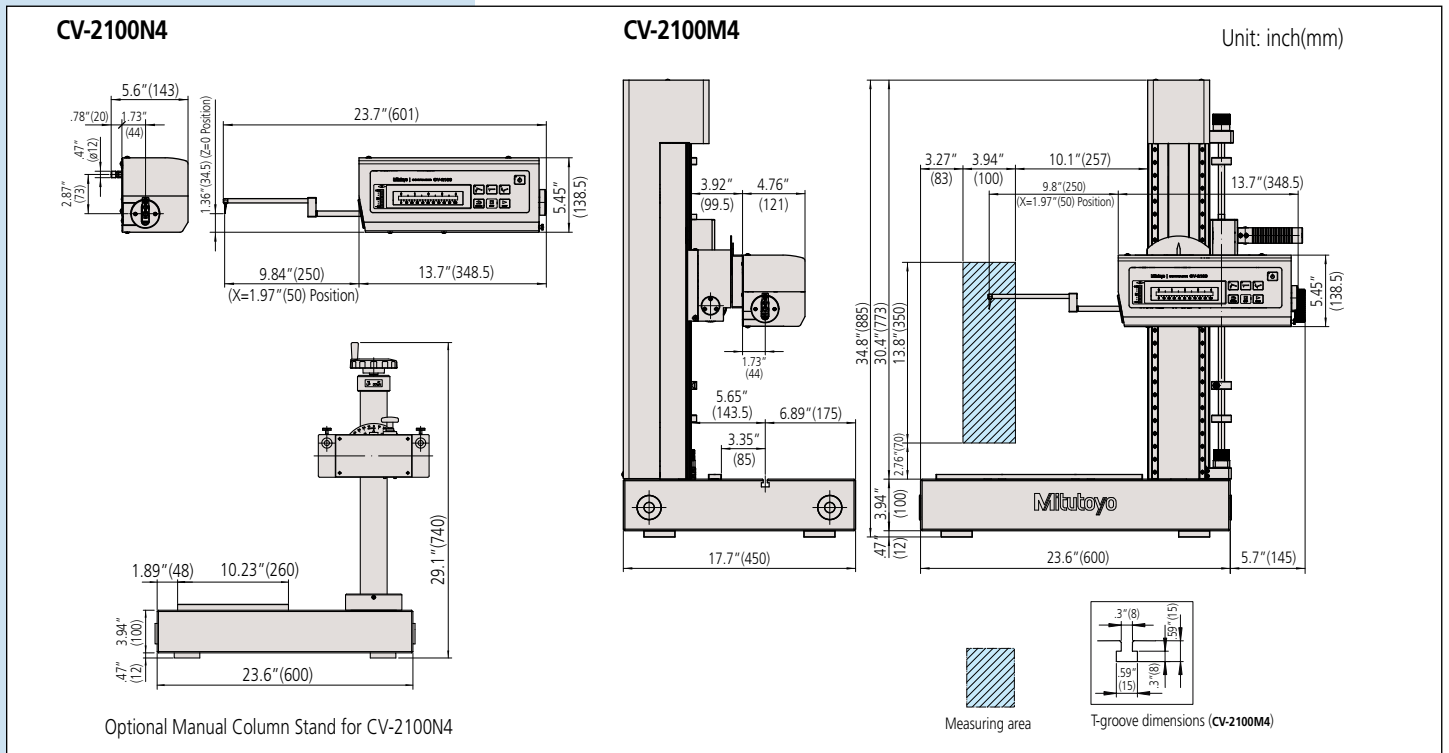

# Contracer CV-3200 / CV-4500

SERIES 218 — Contour Measuring Instruments



CV-3200L4 (with options)



CV-3200S4 with personal computer system and software

## CV-3200 FEATURES

- Dramatically increased drive speed (X axis: 80 mm/s, Z2 axis: 20 mm/s) further reduces total measurement time.
- In order to maintain the traverse linearity specification for an extended period of time, Mitutoyo has adopted highly rigid ceramic guides that combine the characteristics of smallest secular change and remarkable resistance to abrasion.
- With the support for a wide range of optional peripherals designed for use with the CNC models enables simplified CNC measurement.
- The drive unit (X-axis) and column (Z2-axis) are equipped with a high-accuracy linear encoders (ABS type on Z2-axis). This improves reproducibility of continuous automatic measurement of small holes in the vertical direction and repeated measurement of parts which are difficult to position.
- A newly designed straight arm reduces interference on the workpiece and expands the measurement range in the Z1 axis (height) direction.
- One-touch mounting and removal of the arm.
- X1-axis accuracy:  $\pm(0.8+0.01L)\mu\text{m}^*$   
Z1-axis accuracy:  $\pm(1.6+12HI/100)\mu\text{m}$   
Designed to handle workpieces calling for high accuracy.

\* CV-3200S4, H4, W4 types, L = Drive length, H = Measurement height (mm)

With the addition of a new function for continuously measuring top and bottom faces, the variable measuring force function has become more useful, enabling a wide variety of efficient, high-precision measurements.

## CV-4500 FEATURES

- When combined with the double cone-end stylus (a new product with diametrically opposed contact points), the instrument can continuously measure in the upward and downward directions without the need to change the arm orientation or reset the workpiece fixturing.
- The measuring force can be switched among five levels (upward and downward) from the data-processing program (Formtracepak).
- High-precision and high-speed drive has been achieved, significantly improving measurement efficiency.
- A newly designed straight arm has reduced interference on the workpiece and expanded the measurement range in the Z1 axis (height) direction.
- One-touch mounting and removal of the arm.



## Technical Data

### X-axis

Measuring range: 4" (100mm) or 8" (200mm)  
Resolution: 1.97 $\mu\text{m}$  (0.05 $\mu\text{m}$ )  
Measurement method: Reflective-type linear encoder  
Drive speed: 3.15"/s (80mm/s) and manual  
Measuring speed: .0008 - .79"/s (0.02 - 20mm/s)\*

\*Recommended speed: under 5mm/s  
If using higher speed, stylus tip may be chipped and/or accuracy may be worse, depending on surface condition.

Measuring direction: Forward / Backward  
Traverse linearity: 32 $\mu\text{m}/4"$ , 80 $\mu\text{m}/8"$   
(0.8 $\mu\text{m}/100\text{mm}$ , 2 $\mu\text{m}/200\text{mm}$ )  
\*with the X axis in horizontal orientation

Linear displacement: (31.5+10L) $\mu\text{m}$   
accuracy (at 20°C)  $\{\pm(0.8+0.01L)\mu\text{m}\}$  (CV-3200S4, H4, W4, L4)  
(32+10L) $\mu\text{m}$   
 $\{\pm(0.8+0.01L)\mu\text{m}\}$  (CV-4500S4, H4, W4, L4)  
(31.5+20L) $\mu\text{m}$   
 $\{\pm(0.8+0.02L)\mu\text{m}\}$  (CV-3200S8, H8, W8, L8)  
(32+20L) $\mu\text{m}$   
 $\{\pm(0.8+0.02L)\mu\text{m}\}$  (CV-4500S8, H8, W8, L8)  
\* L = Drive length (mm)

Inclining range:  $\pm 45^\circ$   
Z2-axis (column)  
Vertical travel: 10" (300mm) or 20" (500mm)  
Resolution: 39.4 $\mu\text{m}$  (1 $\mu\text{m}$ )  
Measurement method: ABSOLUTE linear encoder  
Drive speed: 0 - 1.2"/s (0 - 30mm/s) and manual

### Z1-axis (detector unit)

Measuring range:  $\pm 1.2"$  ( $\pm 30\text{mm}$ )  
Resolution: 1.57 $\mu\text{m}$  (0.04 $\mu\text{m}$ ) (CV-3200 series),  
.78 $\mu\text{m}$  (0.02 $\mu\text{m}$ ) (CV-4500 series)

Measurement method: Rotary arc encoder (CV-3200 series),  
(CV-4500 series)

Linear displacement  
Accuracy (at 20°C):  $\pm(63+120HI)\mu\text{m}$  ( $\pm(1.4+12HI/100)\mu\text{m}$ ) (CV-3200 series)  
 $\pm(32+120HI)\mu\text{m}$  ( $\pm(0.8+12HI/100)\mu\text{m}$ ) (CV-4500 series)  
\*H: Measurement height from the horizontal position (mm)

Stylus up/down operation: Arc movement  
Face of stylus: Upward/downward  
Measuring force: 30mN (CV-3200)  
Measuring force: 10, 20, 30, 40, 50mN (CV-4500)  
(Specified from the data-processing program)

Formtracepak  
Traceable angle: Ascent: 77°, descent: 83°  
(using the standard stylus provided and depending on the surface roughness)

Stylus tip  
Base size (W x H): 17.7 x 23.6" (450 x 600mm) or  
39.4 x 17.7" (1000 x 450mm)

Base material: Granite  
Power supply: 100 - 240VAC  $\pm 10\%$ , 50/60Hz  
Power consumption: 400W (main unit only)

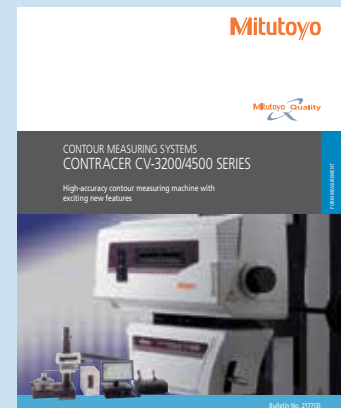

Refer to Bulletin No. (2177) for more details.

# Contracer CV-3200 / CV-4500

## SERIES 218 — Contour Measuring Instruments

### SPECIFICATIONS

Model No.	CV-3200S4	CV-3200H4	CV-3200W4	CV-3200L4
Order No. (inch)	<b>218-491-10A</b>	<b>218-492-10A</b>	<b>218-493-10A</b>	<b>218-494-10A</b>
Model No.	CV-4500S4	CV-4500H4	CV-4500W4	CV-4500L4
Order No. (inch)	<b>218-451-10A</b>	<b>218-452-10A</b>	<b>218-453-10A</b>	<b>218-454-10A</b>
X1-axis measuring range	4" (100mm)	4" (100mm)	4" (100mm)	4" (100mm)
Vertical travel	12" (300mm) power column	20" (500mm) power column	20" (500mm) power column	27.6" (700mm) power column
Granite base size (WxD)	23.6 x 17.7" (600 x 450mm)	23.6 x 17.7" (600 x 450mm)	39.4 x 17.7" (1000 x 450mm)	39.4 x 17.7" (1000 x 450mm)
Dimensions (main unit, WxDxH)	29.2 x 17.7 x 35.6" (741 x 450 x 905mm)	29.2 x 17.7 x 43.5" (741 x 450 x 1105mm)	45.5 x 19 x 46.3" (1156 x 482 x 1176mm)	45.5 x 19.4 x 56.5" (1156 x 492 x 1436mm)
Mass (main unit)	309 lbs (140kg)	331 lbs (150kg)	485 lbs (220kg)	595 lbs (270kg)
Model No.	CV-3200S8	CV-3200H8	CV-3200W8	CV-3200L8
Order No. (inch)	<b>218-496-10A</b>	<b>218-497-10A</b>	<b>218-498-10A</b>	<b>218-499-10A</b>
Model No.	CV-4500S8	CV-4500H8	CV-4500W8	CV-4500L8
Order No. (inch)	<b>218-456-10A</b>	<b>218-457-10A</b>	<b>218-458-10A</b>	<b>218-459-10A</b>
X1-axis measuring range	8" (200mm)	8" (200mm)	8" (200mm)	8" (200mm)
Vertical travel	12" (300mm) power column	20" (500mm) power column	20" (500mm) power column	27.6" (700mm) power column
Granite base size (WxD)	23.6 x 17.7" (600 x 450mm)	23.6 x 17.7" (600 x 450mm)	39.4 x 17.7" (1000 x 450mm)	39.4 x 17.7" (1000 x 450mm)
Dimensions (main unit, WxDxH)	30.2 x 19 x 38" (767 x 482 x 966mm)	30.2 x 19 x 46" (767 x 482 x 1166mm)	45.9 x 19 x 46.3" (1166 x 482 x 1176mm)	45.9 x 19.4 x 56.5" (1166 x 492 x 1436mm)
Mass (main unit)	309 lbs (140kg)	331 lbs (150kg)	485 lbs (220kg)	595 lbs (270kg)

### Collective Calibration Function

- A dedicated calibration gage enables the user to calibrate the instrument for Z-axis gain, symmetry, stylus-tip radius, etc., in a single procedure.

Calibration kit for CV-4500 series

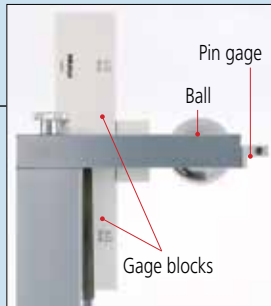

Calibration Kit:  
CV-4500: **12AAQ491**  
CV-3200: **12AAQ489** (not shown)

### Software

#### FORMTRACEPAK V5



Measurement Control Screen



Profile Analysis Screen

Report Creation Function

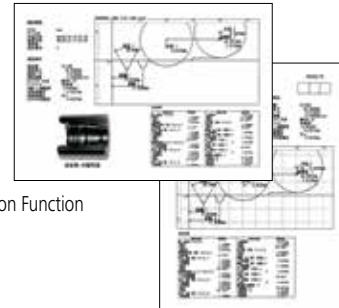

Automatic Circle/Line Application Function

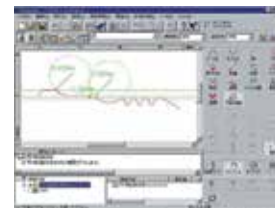

Data Composition Function

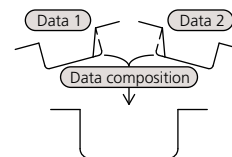

**MiCAT**

Mitutoyo-Intelligent Computer Aided Technology

the standard in world  
metrology software

**FORM**

# Optional Arms and Styli for Contour Measurement

For CV-2100

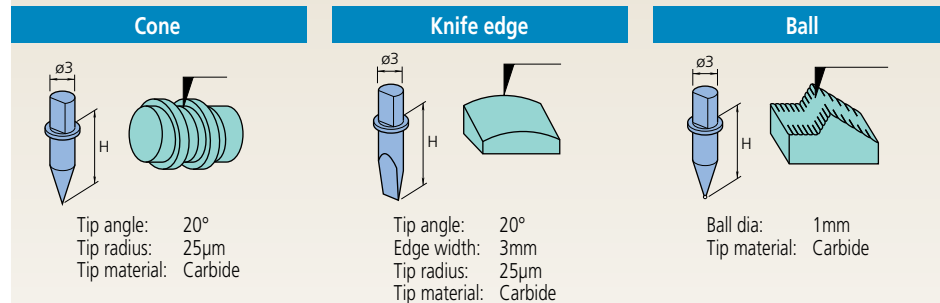
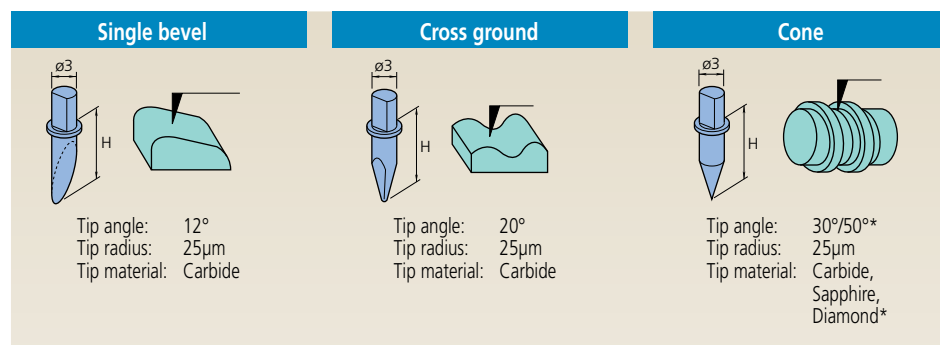
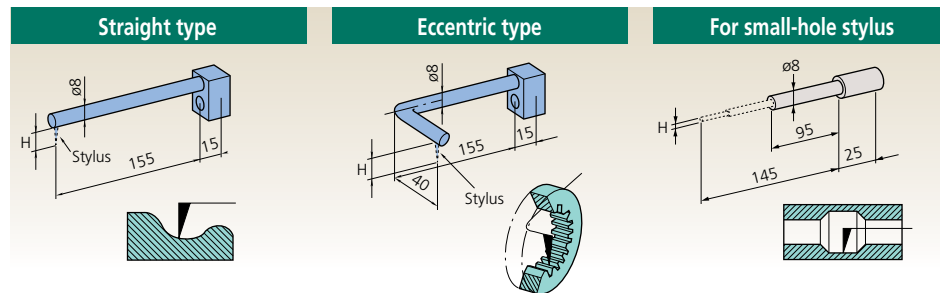

Small hole: 932693 / 12AAE873

Small hole: 932694 / 12AAE874

Small hole: 932695 / 12AAE875

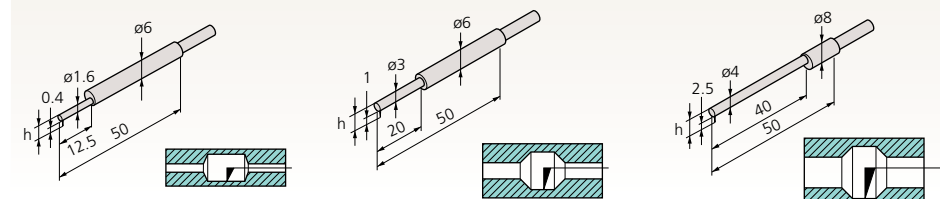

**932693**    **12AAE873**  
 Tip shape: Single bevel    Cone  
 Tip angle:  $20^\circ$      $30^\circ$   
 Tip radius:  $25\mu\text{m}$      $25\mu\text{m}$   
 Tip material: Carbide    Carbide

**932694**    **12AAE874**  
 Tip shape: Single bevel    Cone  
 Tip angle:  $20^\circ$      $30^\circ$   
 Tip radius:  $25\mu\text{m}$      $25\mu\text{m}$   
 Tip material: Carbide    Carbide

**932695**    **12AAE875**  
 Tip shape: Single bevel    Cone  
 Tip angle:  $20^\circ$      $30^\circ$   
 Tip radius:  $25\mu\text{m}$      $25\mu\text{m}$   
 Tip material: Carbide    Carbide

## List of Applicable Arms

Arm name	Order No.	Compatible stylus height
Straight type	935111	H = 6mm
	935112	H = 12mm
	935113	H = 20mm
	935114	H = 30mm
	935115	H = 42mm
Eccentric type	935116	H = 6mm
	935117	H = 12mm
	935118	H = 20mm
	935119	H = 30mm
	935120	H = 42mm
Small hole	935110	H = 0.4, 1, 2.5mm

## List of Applicable Styli

Stylus name	Order No.	Stylus height
Single-bevel stylus carbide-tipped	354882	H = 6mm
	354883	H = 12mm
	354884	H = 20mm
	354885	H = 30mm
Cross-ground stylus carbide-tipped	354886	H = 42mm
	354887	H = 6mm
	354888	H = 12mm
	354889	H = 20mm
Cone stylus carbide-tipped tip angle $20^\circ$	354890	H = 30mm
	354891	H = 42mm
	12AAE865	H = 6mm
	12AAE866	H = 12mm
Cone stylus sapphire tipped tip angle $30^\circ$ *Diamond tipped *tip angle $50^\circ$	12AAE867	H = 20mm
	12AAE868	H = 30mm
	12AAE869	H = 42mm
	354892	H = 6mm
Cone stylus carbide-tipped tip angle $30^\circ$	354893	H = 12mm
	354894	H = 20mm
	355129*	H = 20mm
	354895	H = 30mm
Cone stylus carbide-tipped tip angle $20^\circ$	354896	H = 42mm
	12AAA566	H = 6mm
	12AAA567	H = 12mm
	12AAA568	H = 20mm
Knife-edge stylus carbide-tipped	12AAA569	H = 30mm
	12AAA570	H = 42mm
	354897	H = 6mm
	354898	H = 12mm
Ball stylus carbide-tipped	354899	H = 20mm
	354900	H = 30mm
	354901	H = 42mm
	354902	H = 6mm
Small-hole stylus carbide-tipped single bevel	354904	H = 20mm
	354905	H = 30mm
	354906	H = 42mm
Small-hole stylus carbide-tipped cone	932693	H = 2mm
	932694	H = 4mm
	932695	H = 6.5mm
Small-hole stylus carbide-tipped cone	12AAE873	H = 2mm
	12AAE874	H = 4mm
	12AAE875	H = 6.5mm



# Optional Styli for Contour Measurement

CV-2100, CV-3200, CV-4500, SV-C3200, SV-C4500 and SV-C4500CNC

## List of Applicable Styli

Stylus name	Order No.	Stylus height
Single-bevel cut stylus carbide-tipped	354882	H = 6mm
	354883	H = 12mm
	354884	H = 20mm
	354885	H = 30mm
	354886	H = 42mm
Cross-ground stylus carbide-tipped	354887	H = 6mm
	354888	H = 12mm
	354889	H = 20mm
	354890	H = 30mm
	354891	H = 42mm
Cone stylus carbide-tipped tip angle 20°	12AAE865	H = 6mm
	12AAE866	H = 12mm
	12AAE867	H = 20mm
	12AAE868	H = 30mm
	12AAE869	H = 42mm
Cone stylus sapphire tipped tip angle 30° *Diamond tipped *tip angle 50°	354892	H = 6mm
	354893	H = 12mm
	354894	H = 20mm
	355129*	H = 20mm
	354895	H = 30mm
	354896	H = 42mm
Cone stylus carbide-tipped tip angle 30°	12AAA566	H = 6mm
	12AAA567	H = 12mm
	12AAA568	H = 20mm
	12AAA569	H = 30mm
	12AAA570	H = 42mm
Knife-edge stylus carbide-tipped	354897	H = 6mm
	354898	H = 12mm
	354899	H = 20mm
	354900	H = 30mm
	354901	H = 42mm
Ball stylus carbide-tipped	354902	H = 6mm
	354904	H = 20mm
	354905	H = 30mm
	354906	H = 42mm

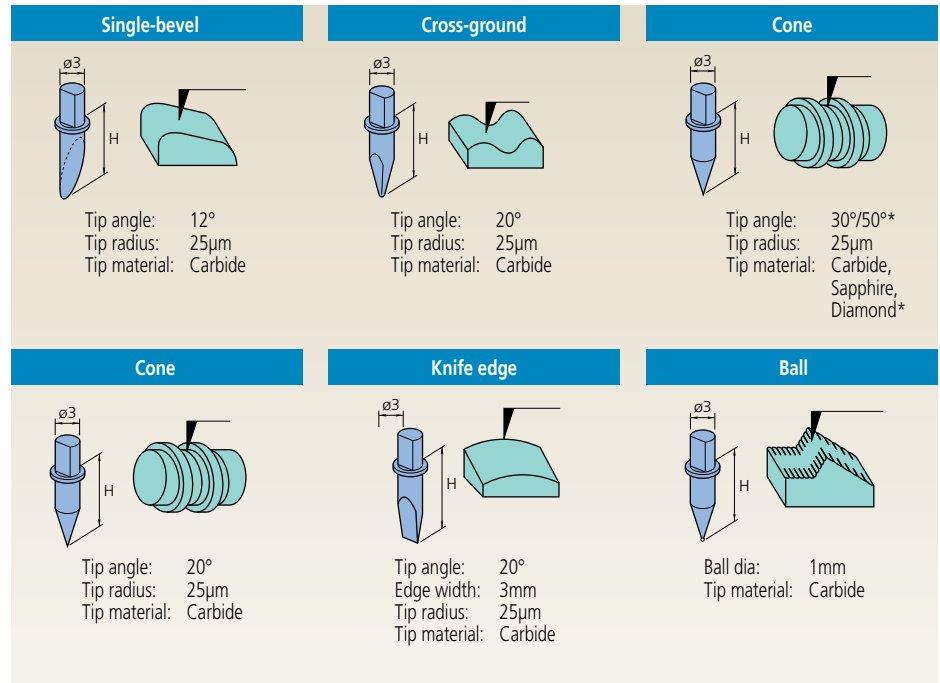

• Any specified arm and stylus other than above listed can be custom-made for special order.

### Arm and Stylus set: 12AAR588

Set for CV-4500 / SV-C4500 / SV-C4500CNC

Part	Part No.	Part Description
Arm	12AAQ762	Eccentric arm
	12AAM103	Small-hole arm
Stylus	354889	Cross-ground stylus
	354882	Single-bevel cut stylus
	12AAA568	Cone stylus
	12AAM104	Small hole stylus
	12AAM106	Small hole stylus
	12AAM096	Double-sided cone stylus
	12AAM097	Double-sided cone stylus
Integrated arm and stylus	12AAM109	Double-sided small hole arm stylus

### Arm and Stylus set: 12AAR587

Set for CV-3200 / CV-4500 / SV-C3200 / SV-C4500 / SV-C4500CNC

Part	Part No.	Part Description
Arm	12AAQ762	Eccentric arm
	12AAM103	Small-hole arm
Stylus	354889	Cross-ground stylus
	354882	Single-bevel cut stylus
	12AAA568	Cone stylus
	12AAM104	Small hole stylus
	12AAM106	Small hole stylus

# Optional Arms and Styli for Contour Measurement For CV-3200, CV-4500, SV-C3200, SV-C4500 and SV-C4500CNC

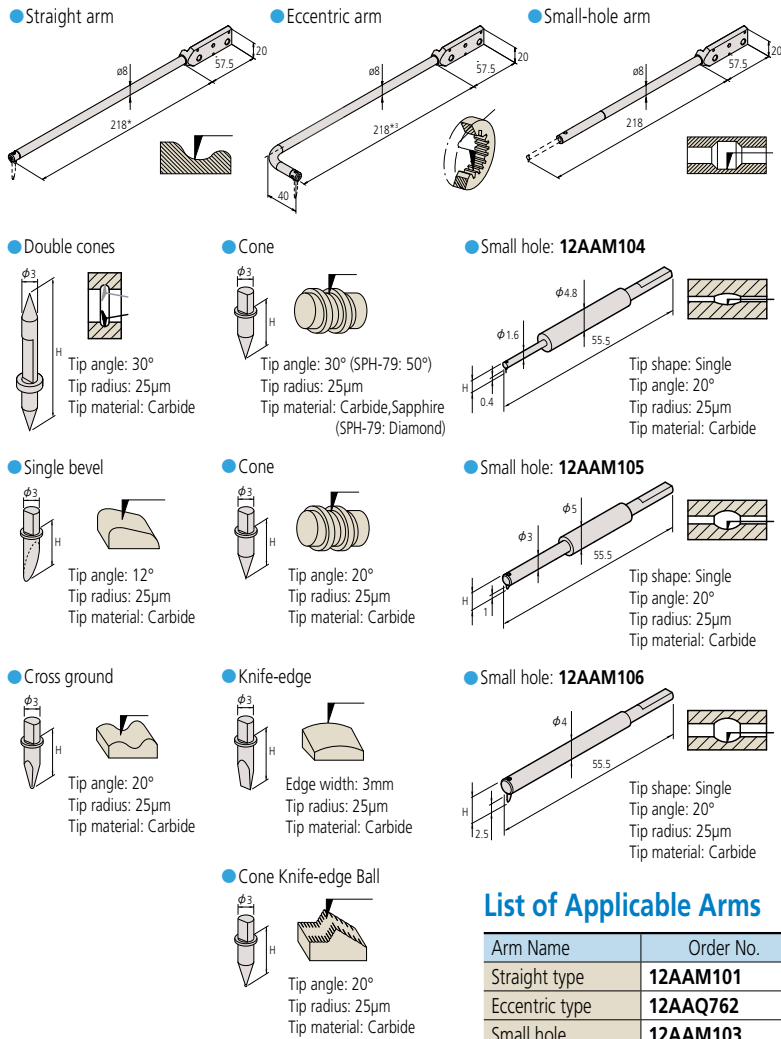

## List of Applicable Arms

Arm Name	Order No.
Straight type	<b>12AAM101</b>
Eccentric type	<b>12AAQ762</b>
Small hole	<b>12AAM103</b>

\*1: Standard accessory  
\*2: Stylus for CV-4500 series  
\*3: One-sided cut stylus SPH-71 (standard accessory) mounting

## List of Applicable Styli

Stylus Name	Order No.	H (mm)
Double cones stylus *4	<b>12AAM095</b> *5	20
	<b>12AAM096</b>	32
	<b>12AAM097</b>	48
Single-bevel stylus carbide-tipped	<b>354882</b>	6
	<b>354883</b>	12
	<b>354884</b> *6	20
	<b>354885</b>	30
	<b>354886</b>	42
Cross-ground stylus carbide-tipped	<b>354887</b>	6
	<b>354888</b>	12
	<b>354889</b>	20
	<b>354890</b>	30
	<b>354891</b>	42
Cone stylus sapphire-tipped tip angle 30°	<b>354892</b>	6
	<b>354893</b>	12
	<b>354894</b>	20
	<b>354895</b>	30
Cone stylus carbide-tipped tip angle 30°	<b>354896</b>	42
	<b>12AAA566</b>	6
	<b>12AAA567</b>	12
	<b>12AAA568</b>	20
Cone stylus carbide-tipped tip angle 20°	<b>12AAA569</b>	30
	<b>12AAA570</b>	42
	<b>12AAE865</b>	6
	<b>12AAE866</b>	12
Cone stylus carbide-tipped tip angle 20°	<b>12AAE867</b>	20
	<b>12AAE868</b>	30
	<b>12AAE869</b>	42
	Cone stylus diamond-tipped tip angle 50°	<b>355129</b>
Knife-edge stylus carbide-tipped	<b>354897</b>	6
	<b>354898</b>	12
	<b>354899</b>	20
	<b>354900</b>	30
Ball stylus carbide-tipped	<b>354901</b>	42
	<b>354902</b>	6
	<b>354904</b>	20
	<b>354905</b>	30
Small-hole stylus *7	<b>354906</b>	42
	<b>12AAM104</b>	2
	<b>12AAM105</b>	4
	<b>12AAM106</b>	6.5

\*4: Stylus for CV-4500 series  
\*5: Standard accessory of CV-4500 series  
\*6: Standard accessory of CV-3200 series  
\*7: Styli SPH-21, 22, and 23 for CV-3100/4100 series are not available.

## Arm stylus (integrated arm and stylus) only for CV-4500

Arm stylus name	Order No.	H (mm)	Tip angle
Double small-hole arm stylus *8	<b>12AAT469</b>	2.4	20°
	<b>12AAT470</b>	5	20°
	<b>12AAM108</b>	2.4	30°
	<b>12AAM109</b>	5	30°
	<b>12AAM110</b>	9	30°

\*8: Arm Stylus for CV-4500, SV-C4500 and SV-C4500CNC series. series

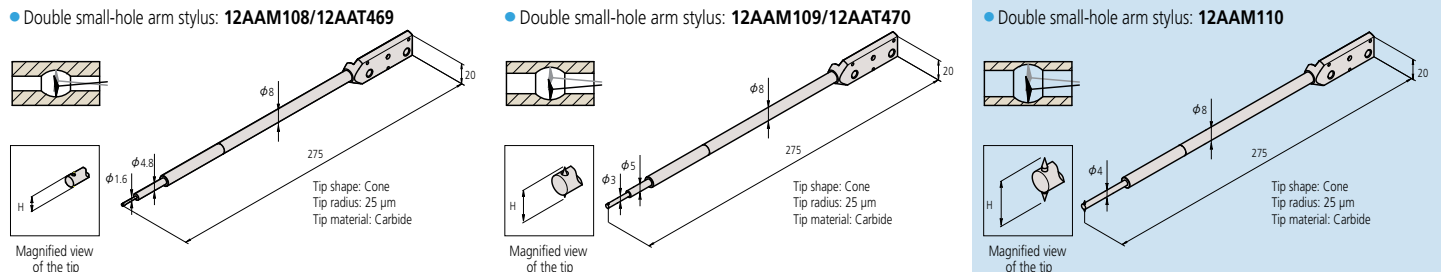

# Optional Accessories for Automatic Measurement

Compatible with CV-3200, CV-4500 and CNC Models

## Y-axis table\*: 178-097

A Y-axis table for both positioning and capable of 3D surface roughness measurement when used with optional software FTPK-PRO or MCubeMap.\*\*  
\*Not supporting Y-axis measurements. \*\* Only for 178-096

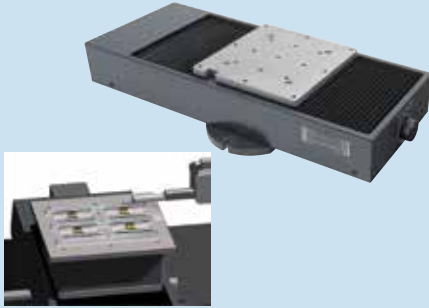

	178-097	178-096
Travel range	8" (200mm)	4" (100mm)
Resolution	1.97µm (0.05µm)	1.97µm (0.05µm)
Positioning accuracy	±3µm	±1µm
Drive speed	Max. 3.15"/s (80mm/s)	Max. .78"/s (20mm/s)
Maximum load	110 lbs (50kg)	33 lbs (50kg)
Mass	62 lbs (28kg)	68 lbs (31kg)

## θ2-axis table: 178-078\*

You can measure multiple points on a cylindrical workpiece and automate front/rear-side measurement.  
\*θ2-axis mounting plate (12AAE718) is required when directly installing on the base of the SV-3100.

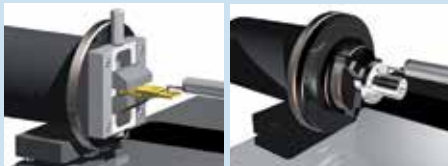
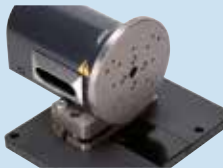

Displacement	360°
Resolution	0.0072°
Maximum load (loading moment)	4kg (343N•cm or less)
Rotational speed	Max. 18°/s
Mass	11 lbs (5kg)

## Quick chuck: 211-032

This chuck is useful when measuring small workpieces. You can easily clamp them with its knurled ring.



Retention range	Inner latch	OD: ø .04 - 1.42" (1 - 36mm)
	Inner latch	ID: ø .55 - 2.76" (14 - 70mm)
	Outer latch	OD: ø .04 - 2.95" (1 - 75mm)
Dimensions	ø 4.65 x 1.61" (118 x 41mm)	
Mass	2.65 lbs (1.2kg)	

## θ1-axis table: 12AAD975\*

For efficient measurement in the axial/transverse directions. When measuring a cylindrical workpiece, automatic alignment can be performed in combination with the Y-axis table.

\*θ1-axis mounting plate (12AAE630) is required when directly installing on the base of the SV-3100.

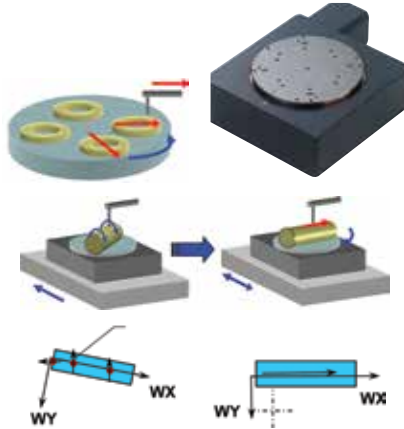

Displacement	360°
Resolution	0.004°
Maximum load	26.5 lbs (12kg)
Rotational speed	Max. 10°/s
Mass	15 lbs (7kg)

## Automatic-leveling table:178-087 (SV, CV, CS3200)

## Automatic-leveling table:178-037 (CNC Models)

This is a stage that performs fully automatic leveling as measurement starts, freeing the user from this troublesome operation. Fully automatic leveling can be done quickly by anyone. In addition, the operation is easy and reliable.



Inclination adjustment angle	±2°
Maximum load	7kg
Table dimensions	130 x 100mm
Mass	7.7lbs (3.5kg)

## Micro-chuck: 211-031

This chuck is suitable for clamping extra-small diameter workpieces (ø1 mm or less), which cannot be retained with the centering chuck.



Retention range	OD: ø 0 - .06" (0 - 1.5mm)
Dimensions	ø 4.65" x 1.9" (118 x 48.5mm)
Mass	1.32 lbs (0.6kg)

## Examples of optimal combinations of accessories for CNC models

Optional accessory	Y-axis Table	θ1 Table	θ2 Table
Function			
Automatic alignment (Patented: Japan)	●	●	—
Multiple workpiece batch measurement	▲	—	—
Multiple-piece measurement in the Y-axis direction (Positioning in the Y-axis direction)	●	—	—
Multiple-piece measurement in the radius direction (Positioning in the rotating direction of XY plane)	▲	●	—
Tracking measurement in the Z-axis direction *	—	—	—
Inclined surface measurement in the X-axis direction	▲	—	—
Inclined hole inside measurement in the X-axis direction	▲	—	—
Multiple cylinder generatrix line measurement	▲	—	●
Measurement of both top and bottom surfaces	▲	—	●
Rotary positioning of large workpiece **	—	—	—
Upward/downward and forward/backward measurement of large workpiece **	—	—	—

\* : Applicable only to form/contour measurement

\*\* : Applicable only for SV-M3000CNC

▲ Recommended ● Essential — Not necessary

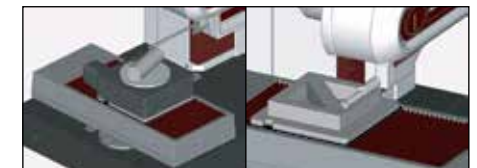
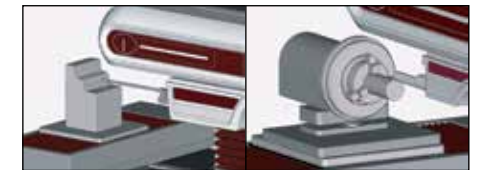
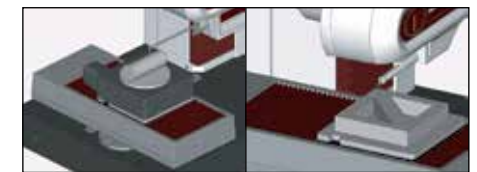

# Optional Accessories for Contracer / Formtracer

Compatible with Desktop Models of Contracer and Formtracer

## Cross-travel table

- Table top: 11" x 7" (280 x 180mm)
- XY travel: 3.94" x 1.97" (100 x 50mm)
- Max. load 110 lbs (50kg)



218-001 (mm)  
218-011 (inch)

- Table top: 11" x 5.98" (280 x 152mm)
- XY travel: 1.97" x .98" (50 x 25mm)
- Max. load 44 lbs (20kg)



218-041 (mm)  
218-051 (inch)

## Rotary vise

- Two-slide jaw type.
- Max. workpiece size:  $\varnothing$  2.36" (60mm)
- Minimum reading: 1°



218-003

- One-slide jaw type.
- Max. workpiece size:  $\varnothing$  2.36" (60mm)
- Minimum reading: 5°



172-144

## Leveling table

- Table top: 5.12" x 3.94" (130 x 100mm)
- Leveling range:  $\pm 1.5^\circ$
- Height: 1.57" (40mm)



178-016

## V-block with clamp

- Used with a cross-travel table or rugged table.
- Max. workpiece diameter: 1.97" (50mm)
- Max. workpiece diameter: .98" (25mm)



172-378  
172-234

- Workpiece diameter: 0.039" to 6.3" (1mm to 160mm)
- Can be mounted on a leveling table

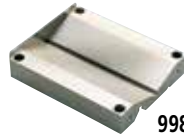

998291

## Leveling table

- Table top: 5.12" x 3.94" (130 x 100mm)
- Leveling range:  $\pm 1.5^\circ$
- XY travel: .49"  $\pm$  (12.5mm)



178-043-1 (mm)  
178-053-1 (inch)

## Digital leveling table

- Table top: 5.12" x 3.94" (130 x 100mm)
- Leveling range:  $\pm 1.5^\circ$
- XY travel: .49"  $\pm$  (12.5mm)



178-042-1 (mm)

## Three-axis adjustment table



178-047  
(V-block not included)

## Precision vise

- Max. workpiece size: 1.42" (36mm)
- Can be mounted on a leveling table.



178-019

## Holder with clamp

- Used with a cross-travel table or rugged table.
- Max. workpiece height: 1.38" (35mm)

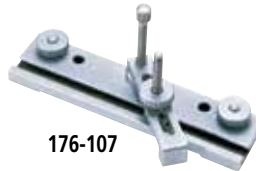

176-107

## Swivel center support

- Max. workpiece diameter: 3.15" (80mm)\*  
\*2.56" (65mm) when swiveled 10°
- Max. workpiece length: 5.51" (140mm)



172-197

## Center support

- Max. workpiece diameter: 4.72" (120mm)
- 2.36" (60mm) riser is optional (172-143)



172-142

## Center support riser

- Used with a center support.
- Max. workpiece diameter: 9.45" (240mm)



172-143

Drive unit tilting function (Patent pending: Japan)	Large $\theta$ Table	Rotary-type detector holder
▲	—	—
—	—	—
—	—	—
—	—	—
—	—	—
—	—	—
●	—	—
●	—	—
—	—	—
—	—	—
—	●	—
—	—	●

●: Essential

▲: Recommended

—: Not necessary

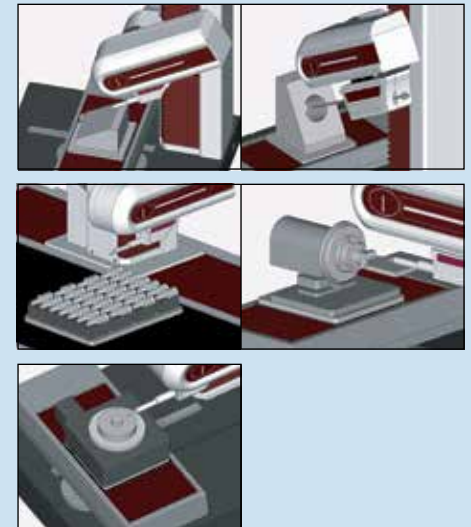

## Three-axis adjustment table

Order No.	178-047
Table top	5.11 x 3.94" (130 x 100mm)
Workpiece weight	33lbs. (15kg) at max.
Workpiece diameter	.04 - 6.3" (1 - 160mm)
Leveling range	$\pm 1.5^\circ$
Swivel range	$\pm 2^\circ$
Y-axis adjustment	$\pm 0.5"$ ( $\pm 12.5$ mm)
Height	6" (152.5mm)
Mass	19.8lbs. (9kg)
Remarks	V-block (998291) not included

# Quick Guide to Precision Measuring Instruments

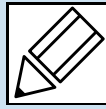

## Contracer (Contour Measuring Instruments)

### Traceable Angle

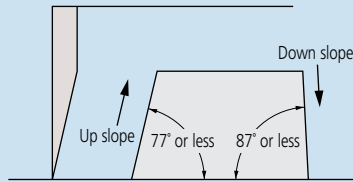

The maximum angle at which a stylus can trace upward or downward along the contour of a workpiece, in the stylus travel direction, is referred to as the traceable angle. A one-sided sharp stylus with a tip angle of  $12^\circ$  (as in the above figure) can trace a maximum  $77^\circ$  of up slope and a maximum  $87^\circ$  of down slope. For a conical stylus ( $30^\circ$  cone), the traceable angle is smaller. An up slope with an angle of  $77^\circ$  or less overall may actually include an angle of more than  $77^\circ$  due to the effect of surface roughness. Surface roughness also affects the measuring force.

For model CV-3200/4500, the same type of stylus (SPH-71: one-sided sharp stylus with a tip angle of  $12^\circ$ ) can trace a maximum  $77^\circ$  of up slope and a maximum  $83^\circ$  of down slope.

### Compensating for Stylus Tip Radius

A recorded profile represents the locus of the center of the ball tip rolling on a workpiece surface. (A typical radius is 0.025mm.) Obviously this is not the same as the true surface profile so, in order to obtain an accurate profile record, it is necessary to compensate for the effect of the tip radius through data processing.

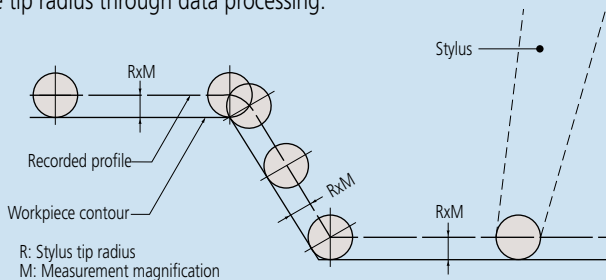

If a profile is read from the recorder through a template or scale, it is necessary to compensate for the stylus tip radius beforehand, according to the applied measurement magnification.

### Compensating for Arm Rotation

The stylus is carried on a pivoted arm so it rotates as the surface is traced and the contact tip does not track purely in the Z direction. Therefore, it is necessary to apply compensation in the X direction to ensure accuracy. There are three methods of compensating for arm rotation.

- 1: Mechanical compensation
- 2: Electrical compensation
- 3: Software processing. To measure a workpiece contour that involves a large displacement in the vertical direction with high accuracy, one of these compensation methods needs to be implemented.

### Accuracy

As the detector units of the X and Z axes incorporate scales, the magnification accuracy is displayed not as a percentage but as the linear displacement accuracy for each axis.

### Overload Safety Cutout

If an excessive force (overload) is exerted on the stylus tip due, perhaps, to the tip encountering a too-steep slope on a workpiece feature, or a burr, etc., a safety device automatically stops operation and sounds an alarm buzzer. This type of instrument is commonly equipped with separate safety devices for the tracing direction (X axis) load and vertical direction (Y axis) load.

For model CV-3200/4500 a safety device functions if the arm comes off the detector mount.

### Simple or Complex Arm Guidance

In the case of a simple pivoted arm, the locus that the stylus tip traces during vertical movement (Z direction) is a circular arc that results in an unwanted offset in X, for which compensation has to be made. The larger the arc movement, the larger the unwanted X displacement ( $\delta$ ) that has to be compensated. (See figure below.) The alternative is to use a complex mechanical linkage arrangement to obtain a linear translation locus in Z, and, therefore, avoid the need to compensate in X.

### Z-axis Measurement Methods

Though the X axis measurement method commonly adopted is by means of a digital scale, the Z axis measurement divides into analog methods (using a differential transformer, etc.) and digital scale methods.

Analog methods vary in Z-axis resolution depending on the measurement magnification and measuring range. Digital scale methods have fixed resolution.

Generally, a digital scale method provides higher accuracy than an analog method.

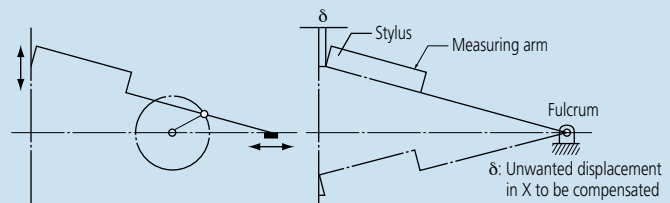

## ■ Contour Analysis Methods

You can analyze the contour with one of the following two methods after completing the measurement operation.

### 1. Data processing section

The measured contour is input into the data processing section in real time and a dedicated program performs the analysis using the mouse and/or keyboard. The angle, radius, step, pitch and other data are directly displayed as numerical values.

### 2. Analysis program

Analysis combining coordinate systems can be easily performed. The graph that goes through stylus radius correction is output to the printer as the recorded profile.

## ■ Tolerancing with Design Data

Measured workpiece contour data can be compared with design data in terms of actual and designed shapes rather than just analysis of individual dimensions. In this technique each deviation of the measured contour from the intended contour is displayed and recorded. Also, data from one workpiece example can be processed so as to become the master design data to which other workpieces are compared. This function is particularly useful when the shape of a section greatly affects product performance, or when its shape has an influence on the relationship between mating or assembled parts.

## ■ Best-fitting

If there is a standard for surface profile data, tolerancing with design data is performed according to the standard. If there is no standard, or if tolerancing only with shape is desired, best-fitting between design data and measurement data can be performed.

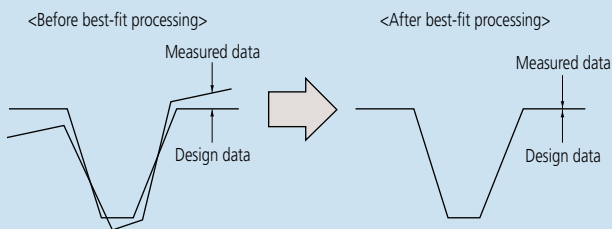

The best-fit processing algorithm searches for deviations between both sets of data and derives a coordinate system in which the sum of squares of the deviations is a minimum when the measured data is overlaid on the design data.

## ■ Data Combination

Conventionally, if tracing a complete contour is prevented by stylus traceable-angle restrictions then it has to be divided into several sections that are then measured and evaluated separately. This function avoids this undesirable situation by combining the separate sections into one contour by overlaying common elements (lines, points) onto each other. With this function the complete contour can be displayed and various analyses performed in the usual way.

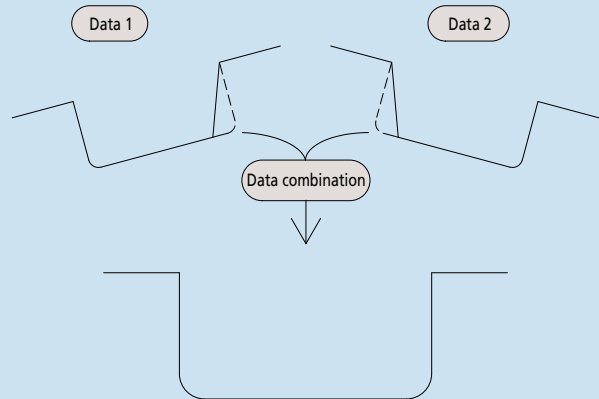

## ■ Measurement Examples



Aspheric lens contour



Inner/outer ring contour of a bearing



Internal gear teeth



Female thread form



Male thread form



Gage contour

# Roundtest RA-120 / 120P

## SERIES 211 — Roundness Measuring Instruments

### Technical Data

Turntable  
 Rotational accuracy: Radial:  $(0.04+6H/10000)\mu\text{m}$   
H: Probing height (mm)  
 Axial:  $(0.04+6X/10000)\mu\text{m}$   
X: Distance from rotation center

Rotating speed: 6rpm  
 Table top diameter:  $\varnothing 1.96''$  (150mm)  
 Centering range:  $\pm 12''$  (3mm)  
 Leveling range:  $\pm 1^\circ$   
 Maximum probing diameter:  $\varnothing 11''$  (280mm)  
 Maximum workpiece diameter:  $\varnothing 17.3''$  (440mm)  
 Maximum workpiece weight: 55 lbs (25kg)

Vertical column (Z-axis)  
 Vertical travel: 11" (280mm)  
 Feeding: 1.18" (30mm)/rev. (coarse),  
 0.039" (1mm)/rev. (fine)

Maximum probing height: 11" (280mm) from the turntable top  
 Maximum probing depth: 3.94" (100mm) (min. ID: 1.18" (30mm))

Horizontal arm (X-axis)  
 Horizontal travel: 65" (165mm) (Including a protrusion  
 of 1" (25mm) the turntable rotation center)

Probe and stylus  
 Measuring range:  $\pm 1000\mu\text{m}$   
 Measuring force: 100mN $\pm$ 30mN  
 Standard stylus: 12AAL021, carbide ball,  $\varnothing 1.6\text{mm}$   
 Measuring direction: Two directional  
 Stylus angle adjustment:  $\pm 45^\circ$  (with graduations)

Data analysis unit:  
 Processing unit: Built-in (PC with Roundpak)\*  
 Data sampling points: 3,600 points/rotation  
 Data analysis items:  
 Roundness, Coaxiality, Concentricity, Flatness, Circular  
 runout (radial), Circular runout (axial), Squareness (against  
 axis), Squareness (against plane), Thickness deviation,  
 Parallelism

Reference circles for roundness evaluation:  
 LSC, MZC, MIC, MCC

Recording device:  
 Built-in thermal line printer (optional external printer)\*

Recording magnification:  
 X5 to X200,000, Auto (X1 to X500,000)\*

Roughness component reduction:  
 Low pass filter, band pass filter

Filter type:  
 2CR-75%, 2CR-50%, 2CRPC-75% (phase corrected),  
 2CRPC-50% (phase corrected), Gaussian, filter OFF

Cutoff value;  
 15 $\mu\text{m}$ , 50 $\mu\text{m}$ , 150 $\mu\text{m}$ , 500 $\mu\text{m}$ , 15-150 $\mu\text{m}$ , 15-500 $\mu\text{m}$ ,  
 50-500 $\mu\text{m}$ , Manual setting\*

Number of measuring sections  
 Max. 5-section (100-section)\*

\*RA-120P

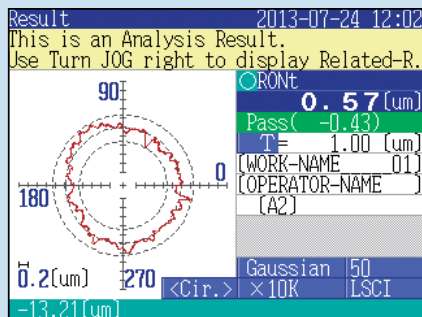

Large color LCD display for RA-120 models

The Roundtest RA-120 / 120P are a compact, affordable, and simple-to-use device for measuring part geometry on the shop floor. It also provides such superb data analysis capabilities as required with laboratory roundness measuring instruments and has a  $\pm 1000\mu\text{m}$  wide range detector and precision turntable with excellent rotation accuracy.



Z-axis scale unit



Optional X-axis stop



RA-120

Order No.: 211-544A (with mechanical mic-heads)  
 Order No.: 211-543A (with DAT function, inch/mm)

### SPECIFICATIONS

Model No.	RA-120*	RA-120D	RA-120P	RA-120PD
Order No.	211-544A	211-543A	211-547A	211-546A

\* Does not include Z-axis scale unit.

The RA-120P is a PC-based model which controls all operations via ROUNDPAK software (optional).



RA-120P

Order No.: 211-547A (with mechanical mic-heads)  
 Order No.: 211-546A (with DAT function, inch/mm)

**MiCAT**

Mitutoyo Intelligent Computer Aided Technology

the standard in world  
metrology software  
**FORM**

**Mitutoyo**

# Roundtest RA-120 / 120P

## SERIES 211 — Roundness Measuring Instruments

### DAT (Digital Adjustment Table) function

The turntable digitally displays the centering and leveling adjustments, turning what used to be a difficult task into one that is simple enough for even new operators to perform.

1. Preliminary measurement of two cross sections: A and B.

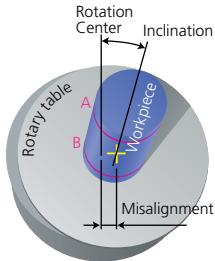

2. Following preliminary measurement, the centering and leveling adjustment values are displayed on the monitor.

3. Manipulate the digital micrometer heads of the rotary table so that the adjustment values displayed on the monitor are realized.

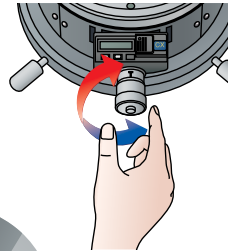

4. Centering and leveling are complete. Centering range:  $\pm 3\text{mm}$  Leveling (inclination) range:  $\pm 1^\circ$

## DIMENSIONS

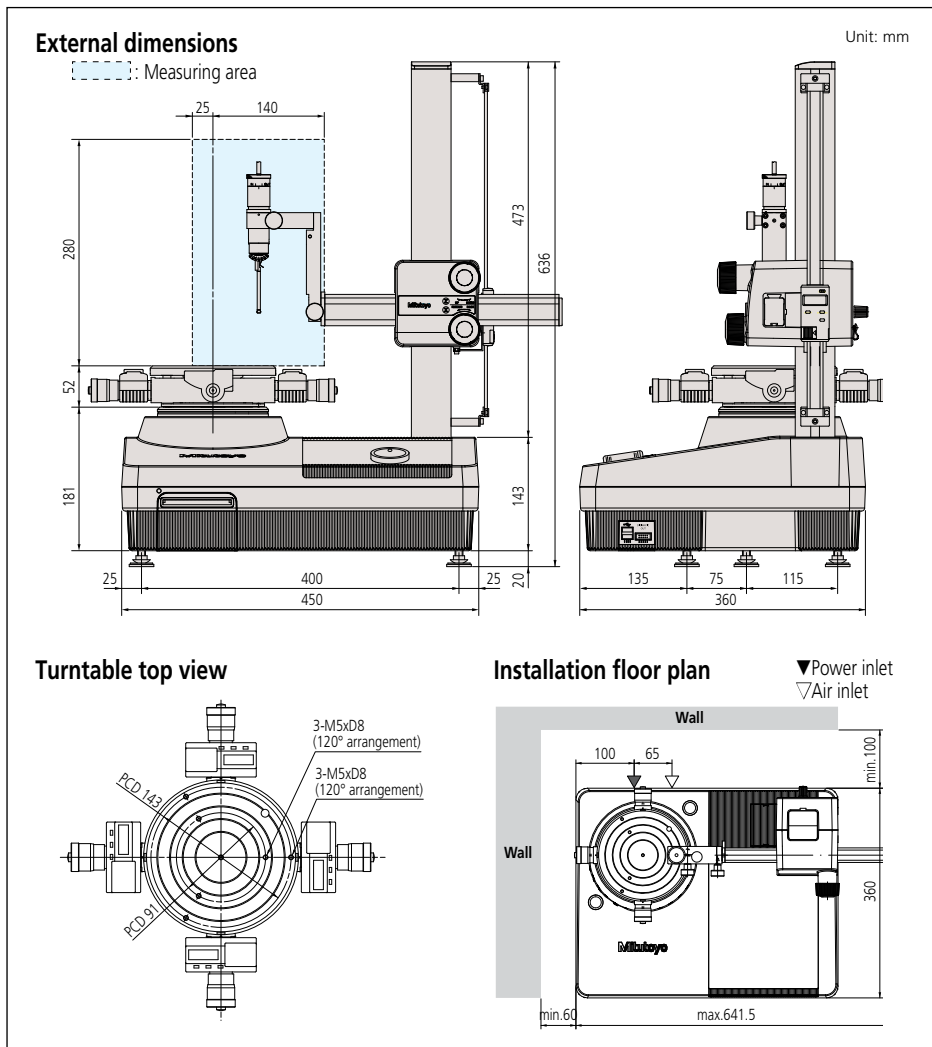

### Functions

- Notched workpiece measurement
- Recalculation of datum/measured data
- Limaçon function compensates for eccentricity
- Rotation of 3D display\*\*
- Real-time display\*\*
- Simplified layout (divided layout)\*\*
- Hair line, auxiliary line, hidden line, fill line\*\*
- Color setting of measured data\*\*
- Offsetting of recorded profile generation\*\*
- Zooming of recorded profile\*\*
- Data deletion\*\*
- Graph analysis (displacement/angle between measured points)\*\*
- Power spectrum analysis\*\*
- Gear tooth analysis\*\*
- Harmonic analysis\*\*
- Text data output (via CSV format)\*\*

\*\*Function of ROUNDPAK software

### Air supply

- Air pressure: 390kPa
- Air consumption: 30L/min.
- Power supply: 100V AC – 240V AC, 50/60Hz
- Dimensions (W x D x H): 17.7" x 14.2" x 25" (450 x 360 x 636mm)
- Mass: 70.5 lbs (32kg) (main unit), 4.4 lbs (2kg) (air regulator)

### Optional Accessories

- **211-032:** Quick chuck (OD: 1 - 79mm, ID: 16 - 69mm)
- **211-014:** Three-jaw chuck (OD: 2 - 78mm, ID: 25 - 68mm)
- **211-031:** Micro-chuck (OD: 1.5mm max.)
- **356038:** Auxiliary stage for a low-height workpiece
- **211-016:** Reference hemisphere
- **211-045:** Magnification checking gage
- **997090:** Gage block set for calibration
- **12AAH320:** X-axis stop
- **211-013:** Vibration damping stand
- **12AAH433:** Z-axis scale unit for RA-120
- —: Interchangeable styli (See page J-49.)

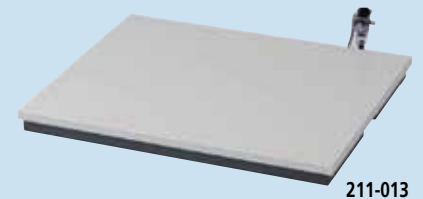

### CONSUMABLE PARTS

- **12AAH181:** Printer paper 10 rolls/set
- **358592:** Element for air filter 1 pc./set
- **358593:** Element for air regulator 10 pcs./set



# Roundtest RA-1600 / RA-1600M

## SERIES 211 — Roundness/Cylindricity Measuring System

### Technical Data

#### Turntable

Rotational accuracy (radial):  $(0.02+6H/10000)\mu\text{m}$  (RA-1600)  
 Rotational accuracy (axial):  $(0.02+6X/10000)\mu\text{m}$  (RA-1600)  
 Rotational accuracy (radial):  $(0.03+6H/10000)\mu\text{m}$  (RA-1600M)  
 Rotational accuracy (axial):  $(0.03+6X/10000)\mu\text{m}$  (RA-1600M)  
 H: Probing height (mm), X: Probing radius (mm)

Rotational speed: 4, 6, 10rpm  
 Table top diameter:  $\phi 5.9"$  (150mm)  
 Centering range:  $\pm 3\text{mm}$  (with DAT function)  
 Leveling range:  $\pm 1^\circ$  (with DAT function)  
 Maximum probing diameter:  $\phi 11"$  ( $\phi 280\text{mm}$ )  
 Maximum workpiece diameter:  $\phi 22"$  ( $\phi 560\text{mm}$ )  
 Maximum table loading: 55lbs (25kg)

#### Vertical column (Z-axis)

Vertical travel: 11.8" (300mm)  
 Straightness (in narrow range):  $0.20\mu\text{m} / 100\text{mm}$  (RA-1600)  
 Straightness (in entire range):  $0.30\mu\text{m} / 300\text{mm}$  (RA-1600)  
 Straightness (in narrow range):  $0.40\mu\text{m} / 100\text{mm}$  (RA-1600M)  
 Straightness (in entire range):  $0.80\mu\text{m} / 100\text{mm}$  (RA-1600M)  
 Parallelism with turntable axis:  $1.5\mu\text{m} / 300\text{mm}$   
 Positioning speed: Max. 15mm/s  
 Measuring speed: 0.5, 1, 2, 5mm/s  
 Maximum probing height (D/OD): 11.8" (300mm)\*1  
 Maximum probing depth: 91mm (over  $\phi 32$ )  
 3.6" (over  $\phi 1.26"$ ) (91mm (over  $\phi 32$ ))  
 1.97" (over  $\phi 0.27"$ ) (50mm (over  $\phi 7$ ))

#### Horizontal arm (X-axis)

Horizontal travel: 6.5" (165mm) (From table axis  $-1 \sim \pm 5.5"$   
 ( $-25\text{mm} \sim \pm 140\text{mm}$ ))  
 Positioning speed: Max. 15mm/s  
 Measuring speed: 0.5, 1, 2, 5mm/s  
 X-axis straightness:  $2.7\mu\text{m} / 140\text{mm}$  (RA-1600)  
 X-axis parallelism to turntable axis:  
 1.6 $\mu\text{m} / 140\text{mm}$  (RA-1600)

#### Probe and stylus

Measuring range:  $\pm 400\mu\text{m} / \pm 40\mu\text{m} / \pm 4\mu\text{m}$   
 Measuring force: 10–50mN (5 level switching)  
 Standard stylus: **12AAL021**, carbide ball,  $\phi 1.6\text{mm}$   
 Measuring direction: Bi-directional  
 Stylus angle adjustment:  $\pm 45^\circ$  (with graduations)

#### Air supply

Air pressure: 0.39MPa (4kgf/cm<sup>2</sup>)  
 Air consumption: 22L/min.

Power supply: 100V AC – 240V AC, 50/60Hz  
 Dimensions (W x D x H): 35 x 19.3 x 33" (890 x 490 x 840mm)  
 Mass: 375lbs (170kg)

\*1 Use an optional auxiliary stage for measuring a workpiece whose height is 20mm or less.

### ROUNDPAK

The latest roundness/cylindrical form analysis program

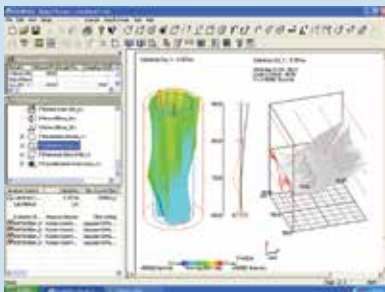

**MiCAT**  
 Mitutoyo Intelligent Computer Aided Technology

the standard in world  
 metrology software  
**FORM**

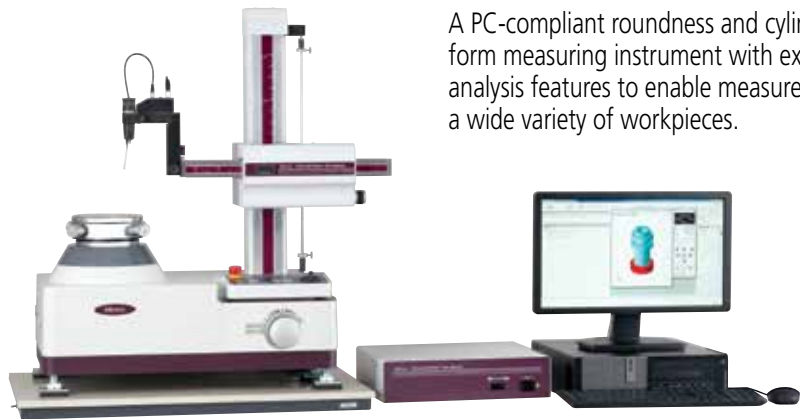

RA-1600 / RA-1600M  
 with personal computer system and software

### Spiral Measurement/Analysis

The spiral-mode measurement function combines table rotation and rectilinear action allowing table cylindrical, coaxiality, and other measurement data to be loaded as a continuous data set.

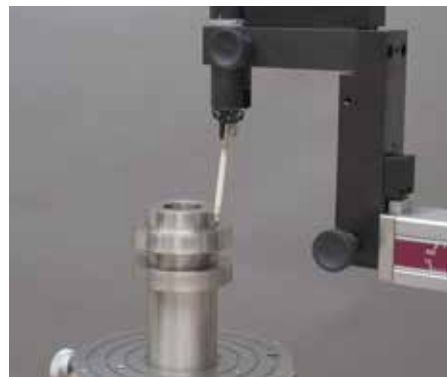

Spiral-mode cylinder measurement

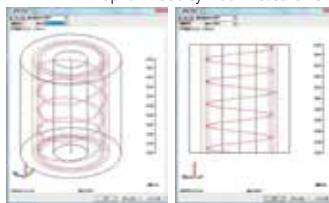

### Safety mechanism provided as a standard feature

A collision-sensing function has been added to the detector unit (when it is in the vertical orientation) to prevent collision in the Z-axis direction. Additionally, an accidental collision prevention function, which stops the system when the detector displacement exceeds its range, has been added. When an accidental touch is detected, the dedicated analysis software (ROUNDPAK) senses the error and automatically stops the system.



A PC-compliant roundness and cylindrical-form measuring instrument with extensive analysis features to enable measurement of a wide variety of workpieces.

### Measurement Through X-axis Tracking

Measurement while tracing is possible through a built-in linear scale in the X-axis. This type of measurement is useful when displacement due to form variation exceeds the measuring range of the detector, and X-axis motion is necessary to maintain contact with the workpiece surface.



### Continuous Internal/External Diameter Measurement

Continuous internal/external diameter measurement is possible without changing the detector position.

- 1, 2) : External diameter measurement
- 3) : Internal diameter measurement
- : Displacement
- 3) = inner diameter: Up to  $\phi 50\text{mm}$

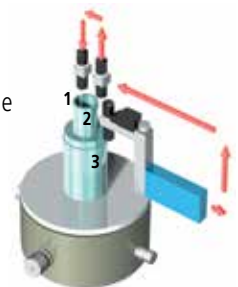

# Roundtest RA-1600 / RA-1600M

## SERIES 211 — Roundness/Cylindricity Measuring System

### Centering and Leveling Function

The turntable displays centering and leveling adjustments digitally, making this challenging task simple enough for even a new operator to perform.

1. Preliminary measurement of two cross sections: A and B.
2. Following preliminary measurement, the centering and leveling adjustment values are displayed on the monitor.

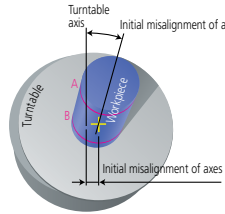

#### For RA-1600

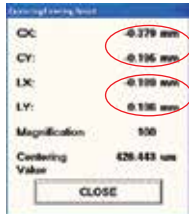

Centering adjustment value

Leveling adjustment value

#### For RA-1600M



3. By adjusting the micrometer heads for the rotary table, the adjustment values or level meter displayed on the monitor can be achieved.

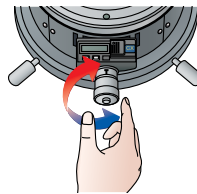

4. Centering and leveling are complete.  
Centering range:  $\pm 3\text{mm}$   
Leveling (inclination) range:  $\pm 1^\circ$

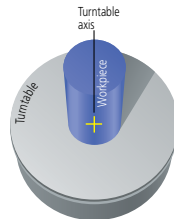

### SPECIFICATIONS

Model No.	RA-1600	RA-1600M
Order No. (inch/mm)	211-733A	211-724A
Mic Heads	Digimatic	Mechanical

### DIMENSIONS

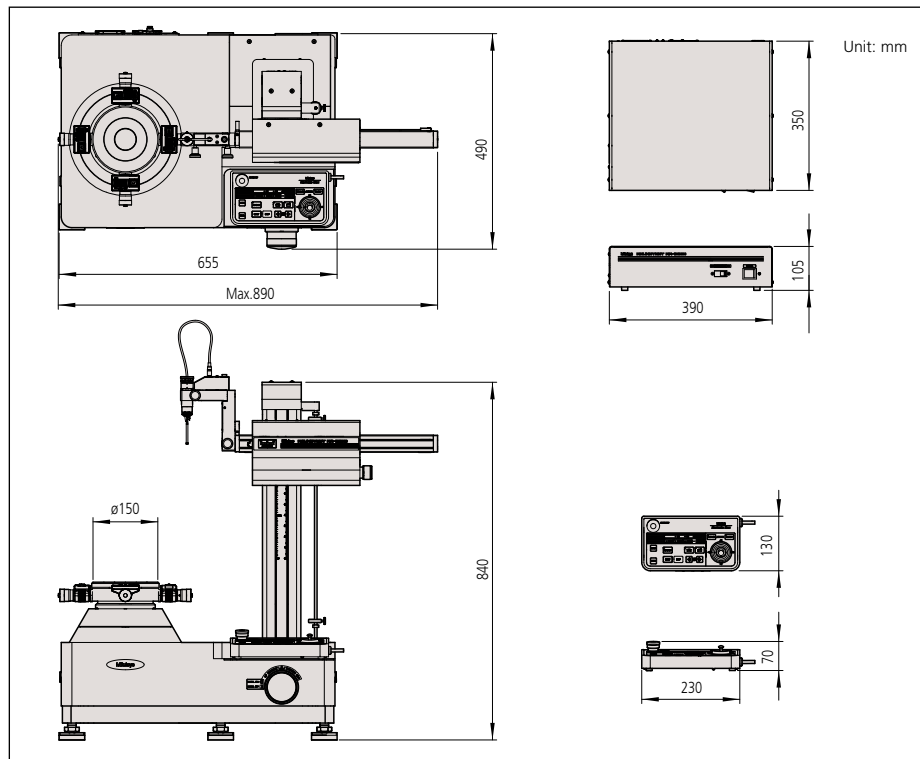

### Optional Accessories

- 350850: Cylindrical square
- 356038: Auxiliary stage for a low-height workpiece
- 12AAF203: 2x extension detector holder
- 12AAF204: Auxiliary detector holder for a large-diameter workpiece
- 12AAL090: Sliding detector holder
- 211-045: Magnification checking gage
- 211-014: Chuck (OD:  $\phi 2 - 78\text{mm}$ , ID:  $\phi 25 - 68\text{mm}$ )
- 211-032: Quick chuck (OD:  $\phi 1 - 79\text{mm}$ , ID:  $16 - 69\text{mm}$ )
- 211-031: Micro-chuck (OD:  $\phi 0.1 - 1.5\text{mm max.}$ )
- 178-025: Vibration isolator (Desktop type)
- 64AAB213: Vibration isolation workstation
- 12AAL019: Side table for PC



### Sliding detector-unit holder (Option) 12AAL090

The detector-unit holder is equipped with a sliding mechanism, enabling one-touch measurement of a workpiece with a deep hole having a thick wall, which has been difficult with the conventional standard arm.



Sliding distance: 4.4" (112mm)

The detector-unit holder can be stopped at a position sufficiently higher than the workpiece and then lowered and positioned to make measurements. Furthermore, internal/external diameters can be easily measured with the continuous internal/external diameter measurement function\*.

\*: See page 41 for details about the continuous ID and OD measuring function.

## Technical Data

Turntable  
 Rotational accuracy (radial):  $\{(0.02+3.5H/10000)\mu\text{m}\}$   
 Rotational accuracy (axial):  $\{(0.02+3.5R/10000)\mu\text{m}\}$   
 H: Probing height (mm), R: Probing radius (mm)

Rotating speed: 2, 4, 6, 10rpm  
 Tabletop diameter:  $\varnothing 9.2''$  (235mm) AS / AH models  
 $\varnothing 7.9''$  (200mm) DS / DH models

Centering range:  $\pm 3\text{mm}$  ( $\pm 5\text{mm}$ : DS / DH models)  
 Leveling range:  $\pm 1^\circ$

Maximum probing diameter:  $\varnothing 11.8''$  (300mm)  
 Maximum workpiece diameter:  $\varnothing 22.8''$  (580mm)  
 Maximum workpiece weight: 66 lbs (30kg)

Vertical column (Z-axis)  
 Vertical travel: 11.8" (300mm) (22.8" (500mm): AH/DH models)  
 Straightness ( $\lambda c 2.5$ ): 0.10  $\mu\text{m}$  / 100mm, 0.15  $\mu\text{m}$  / 300mm  
 (0.25  $\mu\text{m}$  / 500mm: AH / DH models)  
 Parallelism with rotating axis: 0.7  $\mu\text{m}$  / 300mm  
 (1.2  $\mu\text{m}$  / 500mm: AH / DH models)

Positioning speed: Max. 50mm/s  
 Measuring speed: 0.5, 1, 2, 5mm/s  
 Maximum probing height: 11.8" (300mm) (OD / ID)  
 [22.8" (500mm): AH / DH models]  
 Maximum probing depth: over  $\varnothing 32$ : 85mm (w/standard stylus)  
 over  $\varnothing 7$ : 50mm (w/standard stylus)

Horizontal arm (X-axis)  
 Horizontal travel: 6.9" (175mm) (Including a protrusion of 1" (25mm) the turntable rotation center)  
 Straightness ( $\lambda c 2.5$ ): 0.7  $\mu\text{m}$  / 150mm  
 Squareness with rotating axis: 1.0  $\mu\text{m}$  / 150mm  
 Positioning speed: Max. 30mm/s with joystick operation  
 Measuring speed: 0.5, 1, 2, 5mm/s

Probe and stylus  
 Measuring range:  $\pm 400\mu\text{m}/\pm 40\mu\text{m}/\pm 4\mu\text{m}$   
 ( $\pm 5\text{mm}$ : tracking range)  
 Measuring force: 10mN-50mN (in 5 steps)  
 Standard stylus: **12AAL021**, carbide ball,  $\varnothing 1.6\text{mm}$   
 Measuring direction: Two directional  
 Stylus angle adjustment:  $\pm 45^\circ$  (with graduations)

Data analysis system  
 Analysis software: Roundpak  
 Filter type:  
 2CRPC-75%, 2CRPC-50%, 2CR-75% (non-phase corrected), 2CR-50% (non-phase corrected), Gaussian, filter OFF  
 Cutoff value;  
 15upr, 50upr, 150upr, 500upr, 1500upr,  
 15-150upr, 15-500upr, 15-1500upr, 50-500upr,  
 50-1500upr, 150-1500upr, Manual setting  
 Reference circles for roundness evaluation:  
 LSC, MZC, MIC, MCC

Air supply  
 Air pressure: 390kPa (4kgf/cm<sup>2</sup>)  
 Air consumption: 30L/min.  
 Power supply: 100V AC - 240V AC, 50/60Hz  
 Dimensions (W x D x H): 26.3 x 20 x 35.4"  
 (667 x 510 x 900mm)  
 26.3 x 20 x 43.3"  
 (667 x 510 x 1100mm: AH / DH models)

Mass:  
 396 lbs (180kg)  
 440 lbs (200kg) AH / DH models

## Printout

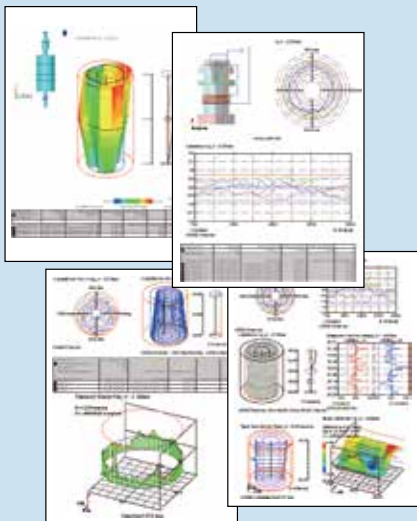

# Roundtest RA-2200AS / DS / AH / DH

## SERIES 211 — Roundness / Cylindricity Measuring System

The RA-2200 provides high accuracy, high speed and high performance in roundness measurement. The fully-automatic, or DAT (Digital Adjustment Table), function-aided manual workpiece centering and leveling turns what used to be a difficult task into one that is simple enough for even new users to

perform. This facilitates substantial reductions in overall measurement time. The RA-2200 system comes complete with powerful data analysis software ROUNDPAK, which requires only simple manipulation using a mouse and icons, achieving enhanced functionality and ease of operation.

### RA-2200AS with personal computer system and software

\* Shown with optional  
vibration isolator and side  
table for PC



### Highly accurate and easy-to-use turntable

With extremely high rotational accuracy, both in the radial and axial directions, the turntable allows high accuracy flatness testing to be performed in addition to roundness and cylindricity measurements.

Incorporating an automatic centering/leveling turntable (A.A.T.), the top-of-the-line RA-2200AS/AH models relieve the operator of the bothersome task of workpiece centering and leveling.

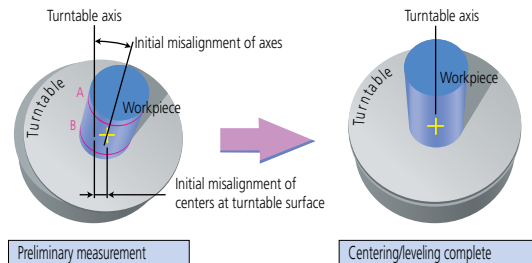

Preliminary measurement of two cross-sections A and B.

Preliminary measurement is followed by automatic centering and leveling.

A guidance system (D.A.T.) is incorporated into the turntables on the RA-2200DS/DH models to help the operator perform manual centering and leveling smoothly and simply.

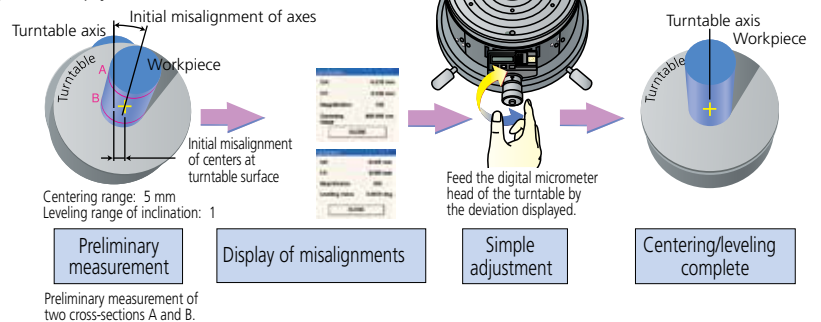

Preliminary measurement of two cross-sections A and B.

# Roundtest RA-2200AS / DS / AH / DH

## SERIES 211 — Roundness / Cylindricity Measuring System

### Greater productivity by continuous measurement

Both the OD and ID of a workpiece\* can be measured in succession without the need for changing the traverse direction of the stylus.

\*Inside diameter up to 50 mm.

Continuous measurement is possible as shown in steps (1) through (3) on the figure at the left, without having to switch the probe direction.

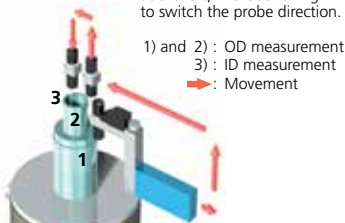

Highly repeatable measurements with high-accuracy scales Mitutoyo linear scales are used in the X/Z drive unit to guarantee the high precision positioning so vital for repetitive measurement.

### Surface roughness measurement function (Surface roughness unit: option)

A surface roughness detector, compliant with the relevant International Standards, can be mounted in place of the roundness measuring detector. This creates a multiple sensor system that can not only test the geometrical roundness/cylindricity of a surface but also the roughness of that surface as well.



## SPECIFICATIONS

Model No.	RA-2200AS	RA-2200DS	RA-2200AH	RA-2200DH
<b>Order No.</b>	<b>211-511A</b> (mm/inch)	<b>211-514A</b> (inch)	<b>211-512A</b> (mm/inch)	<b>211-516A</b> (inch)
Effective table diameter	9.25" (235mm)	8" (200mm)	9.25" (235mm)	8" (200mm)
Centering/leveling adjustment	A.A.T.	D.A.T.	A.A.T.	D.A.T.
Centering range	±0.118" (±3mm)	±0.197" (±5mm)	±0.118" (±3mm)	±0.197" (±5mm)
Column travel	12" (300mm) (standard column)		20" (500mm) (high column)	
Basic unit mass	396 lbs. (180kg)		440 lbs. (200kg)	

## DIMENSIONS

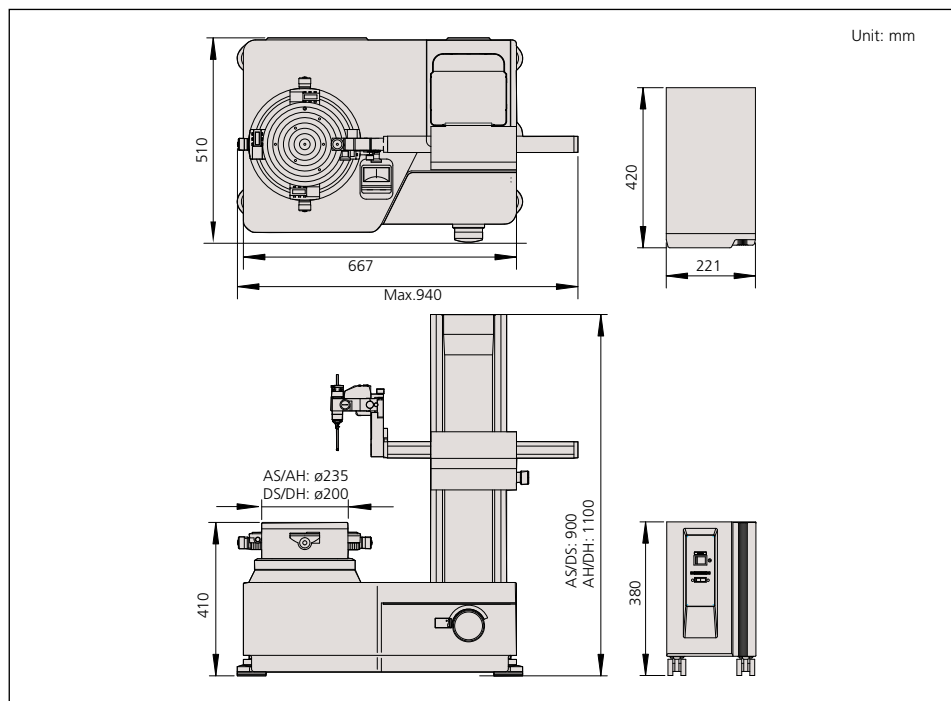

## Optional Accessories

- 350850:** Cylindrical square
- 356038:** Auxiliary stage for a low-height workpiece
- 12AAF203:** Extension probe holder (2X higher)
- 12AAF204:** Auxiliary probe holder for a large diameter workpiece
- 211-045:** Magnification checking gage
- 211-014:** Chuck (OD: 1 - 85mm, ID: 33 - 85mm)
- 211-032:** Quick chuck (OD: 1 - 75mm, ID: 14 - 70mm)
- 211-031:** Micro-chuck (OD: 1.5mm max.)
- 178-025:** Vibration isolator
- 178-024:** Stand for vibration isolator
- \_\_\_\_\_:** Interchangeable styli (See page J-49.)
- 12AAK110:** Vibration isolator
- 12AAK120:** Monitor arm
- 12AAL019:** Side table for PC
- 12AAF353:** Surface roughness detector holder



### Sliding detector-unit holder (Standard) 12AAL090

The detector-unit holder is equipped with a sliding mechanism, enabling one-touch measurement of a workpiece with a deep hole having a thick wall, which has been difficult with the conventional standard arm.



**Sliding distance: 4.4" (112mm)**

The detector-unit holder can be stopped at a position sufficiently higher than the workpiece along the Z-axis, and then lowered and positioned to make measurements. Furthermore, internal/external diameters can be easily measured with the continuous internal/external diameter measurement function\*.

\*: See page 41 for details about the continuous ID and OD measuring function.

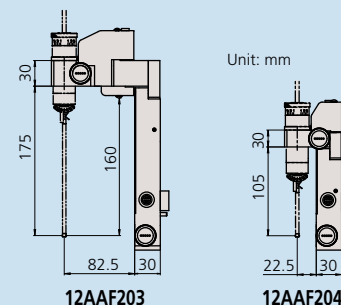

# Roundtest RA-H5200AS / AH

## SERIES 211 — Roundness / Cylindricity Measuring System

### Technical Data

Turntable  
 Rotational accuracy (radial):  $\{(0.02+3.5H/10000)\mu\text{m}\}$   
 Rotational accuracy (axial):  $\{(0.02+3.5X/10000)\mu\text{m}\}$   
H: Probing height (mm), X: Distance from the turntable axis (mm)  
 Rotating speed: 2, 4, 6, 10rpm (20rpm: auto-centering)  
 Table top diameter:  $\varnothing 11.8''$  (300mm)  
 Centering range:  $\pm 5\text{mm}$   
 Leveling range:  $\pm 1^\circ$   
 Maximum probing diameter:  $\varnothing 15.7''$  (400mm)  
 Maximum workpiece diameter:  $\varnothing 26.8''$  (680mm)  
 Maximum workpiece weight: 176 lbs (80kg)  
 143 lbs (65kg): auto-centering

Vertical column (Z-axis)  
 Vertical travel: 13.8" (350mm), (21.7" (550mm): AH model)  
 Straightness ( $\lambda c2.5$ ):  $0.05\mu\text{m} / 100\text{mm}$ ,  $0.14\mu\text{m} / 350\text{mm}$   
 (0.2 $\mu\text{m} / 550\text{mm}$ : AH model)  
 Parallelism with rotating axis:  $0.2\mu\text{m} / 350\text{mm}$   
 (0.32 $\mu\text{m} / 550\text{mm}$ : AH model)  
 Positioning speed: Max. 60mm/s  
 Measuring speed: 0.5, 1, 2, 5mm/s  
 Maximum probing height: 13.8" (350mm) (OD / ID)  
 [21.7" (550mm) (OD / ID): AH model]  
 Maximum probing depth: over  $\varnothing 32$ : 85mm (w/standard stylus)  
 over  $\varnothing 7$ : 50mm (w/standard stylus)

Horizontal arm (X-axis)  
 Horizontal travel: 8.9" (225mm)  
 Straightness ( $\lambda c2.5$ ):  $0.4\mu\text{m} / 200\text{mm}$   
 Squareness with rotating axis:  $0.5\mu\text{m} / 200\text{mm}$   
 Positioning speed: Max. 50mm/s  
 Measuring speed: 0.5, 1, 2, 5mm/s

Probe and stylus  
 Measuring range:  $\pm 400\mu\text{m}$  ( $\pm 5\text{mm}$ : tracking range)  
 Measuring force: 10mN~50mN (in 5 steps)  
 Standard stylus: **12AAL021**, carbide ball,  $\varnothing 1.6\text{mm}$   
 Measuring direction: Two directional  
 Stylus angle adjustment:  $\pm 45^\circ$  (with graduations)

Data analysis system  
 Analysis software: Roundpak  
 Filter type:  
 2CRPC-75%, 2CRPC-50%, 2CR-75% (non-phase corrected), 2CR-50% (non-phase corrected), Gaussian, filter OFF  
 Cutoff value:  
 15upr, 50upr, 150upr, 500upr, 1500upr,  
 15-150upr, 15-500upr, 15-1500upr, 50-500upr, 50-1500upr, 150-1500upr, Manual setting  
 Reference circles for roundness evaluation:  
 LSC, MZC, MIC, MCC

Air supply  
 Air pressure: 390kPa (4kgf/cm<sup>2</sup>)  
 Air consumption: 45L/min.  
 Power supply: 100V AC – 240V AC, 50/60Hz  
 Dimensions (W x D x H): 49.6 x 28.0 x 66.9"  
 (1260 x 710 x 1700mm)  
 49.6 x 28.0 x 74.8"  
 (1260 x 710 x 1900mm: AH model)

Mass: Main unit: 1433lbs. (650kg)  
 1477lbs. (670kg): AH model  
 Vibration isolator: 375 lbs (170kg)

RA-H5200AS / AH, a roundness/cylindricity measuring system developed to combine world-class accuracy with maneuverability/high-analysis capability.

Enhanced detector safety functions, such as accidental touch and collision detection, is installed to minimize damage to both machine and workpieces.



RA-H5200AS  
with personal computer  
system and software

\* Shown with optional  
side table for PC.

### High-accuracy automatic centering/leveling turntable

A highly accurate, highly rigid turntable has been achieved through exceptional manufacturing accuracy of the critical components, such as the rotor and stator, in addition to an air-bearing incorporating a complex aperture that provides superior rigidity and uniform pressure distribution. As a result, the rotational accuracy (radial), which is the heart of the roundness/cylindricity measuring system, is a world-class  $(0.02 + 3.5H/10000)\mu\text{m}$ .



### Automatic continuous OD/ID measurement

Automatic measurement can be performed continuously from external diameter to internal diameter without having to change the probe position. This not only reduces measurement time, but eliminates the error factors otherwise involved in changing the probe position, greatly facilitating high-accuracy measurement.

The automatic centering/leveling mechanism incorporates a high-precision glass scale on each axis of the turntable. This allows feedback to be generated that prevents positioning errors from affecting centering/leveling adjustments. The high-speed, automatic, centering/leveling capability achieved greatly contributes to reducing the total measurement time from workpiece setting to workpiece measurement.

Continuous measurement is possible as shown in steps (1) through (3) on the figure at the left, without having to switch the probe direction.

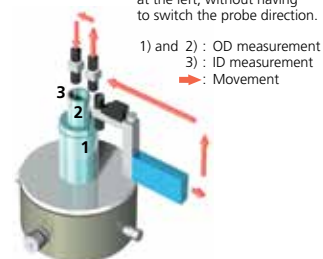

1) and 2) : OD measurement  
 3) : ID measurement  
 → : Movement

# Roundtest RA-H5200AS / AH

## SERIES 211 — Roundness / Cylindricity Measuring System

### X-axis tracking measurement

Because of the linear scale incorporated into the X-axis, measurement can be performed by tracking the workpiece surface (tracking range:  $\pm 5\text{mm}$ ). This function is effective for measuring a workpiece with a displacement that exceeds the detection range of the probe in measuring roundness/cylindricity or a taper that is determined with slider/column movement.

### Surface roughness measurement function (Surface roughness unit: option)

A surface roughness detector, compliant with the relevant international standards, can be mounted in place of the roundness measuring detector. This creates a multiple sensor system that can not only test the geometrical roundness/cylindricity of a surface, but also the roughness of that surface.

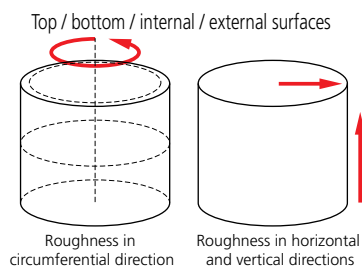

## SPECIFICATIONS

Model No.	RA-H5200AS	RA-H5200AH
Order No. * with vibration isolating stand	211-531A	211-532A
Column travel	13.77" (350mm) (standard column)	21.65" (550mm) (high column)

## DIMENSIONS

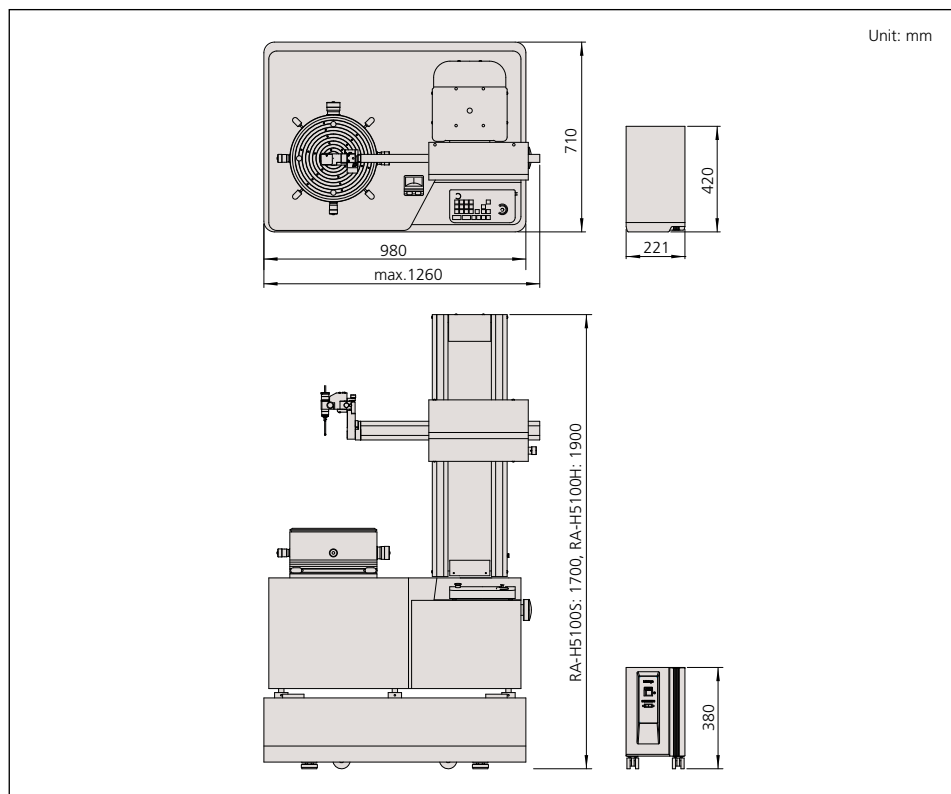

## Optional Accessories

- 350850: Cylindrical square
- 12AAF203: Extension probe holder (2X higher)
- 12AAF205: Extension probe holder (3X higher)
- 12AAF204: Auxiliary probe holder for a large diameter workpiece
- 211-045: Magnification calibration gage
- 211-014: Chuck (OD: 2 - 78mm, ID: 25 - 68mm)
- 211-032: Quick chuck (OD: 1 - 79mm, ID: 16 - 69mm)
- 211-031: Micro-chuck (OD: 0.1~1.5mm max.)
- 12AAB598: Protective shield
- : Interchangeable styli (See page J-49.)
- 12AAL019: Side table for PC



### Sliding detector-unit holder (Standard) 12AAL090

The detector-unit holder is equipped with a sliding mechanism, enabling one-touch measurement of a workpiece with a deep hole having a thick wall, which has been difficult with the conventional standard arm.



Sliding distance: 4.4" (112mm)

The detector-unit holder can be stopped at a position sufficiently higher than the workpiece along the Z-axis, and then lowered and positioned to make measurements. Furthermore, internal/external diameters can be easily measured with the continuous internal/external diameter measurement function\*.

\*: See page 41 for details about the continuous ID and OD measuring function.

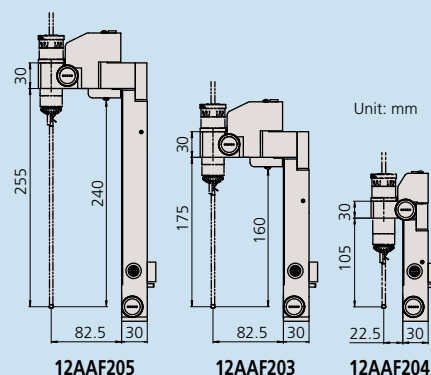

## Technical Data: RA-2200CNC

Turntable  
 Rotational accuracy (radial):  $\{(0.02+3.5H/10000)\mu\text{m}\}$   
 Rotational accuracy (axial):  $\{(0.02+3.5X/10000)\mu\text{m}\}$   
H: Probing height (mm), X: Distance from the turntable axis (mm)  
 Rotating speed: 2, 4, 6, 10rpm  
 Tabletop diameter:  $\varnothing 9.25"$  (235mm)  
 Centering range:  $\pm 3\text{mm}$   
 Leveling range:  $\pm 1^\circ$   
 Maximum probing diameter:  $\varnothing 10.1"$  (256mm)  
 Maximum workpiece diameter:  $\varnothing 22.8"$  (580mm)  
 Maximum workpiece weight: 66 lbs (30kg)

Vertical column (Z-axis)  
 Vertical travel: 11.8" (300mm) 19.7" (500mm: 2200H model)  
 Straightness (c2.5): 0.10 $\mu\text{m}$  / 100mm, 0.15 $\mu\text{m}$  / 300mm  
 (0.25 $\mu\text{m}$  / 500mm: 2200H model)  
 Parallelism with rotating axis: 0.7 $\mu\text{m}$  / 300mm  
 (1.2 $\mu\text{m}$  / 500mm: 2200H model)  
 Positioning speed: Max. 50mm/s  
 Measuring speed: 0.5, 1, 2, 5mm/s  
 Maximum probing height: 11.8" (300mm) (OD / ID)  
 [19.7" (500mm) (OD / ID): 2200H model]  
 Maximum probing depth: over  $\varnothing 32$ : 104mm (w/standard stylus)  
 over  $\varnothing 12.7$ : 26mm (w/standard stylus)

Horizontal arm (X-axis)  
 Horizontal travel: 6.9" (175mm) (Including a protrusion of  
 1" (25mm) the turntable rotation center)  
 Straightness (c2.5): 0.7 $\mu\text{m}$  / 150mm  
 Squareness with rotating axis: 1.0 $\mu\text{m}$  / 150mm  
 Positioning speed: Max. 30mm/s  
 Measuring speed: 0.5, 1, 2, 5mm/s

Probe and stylus  
 Measuring range:  $\pm 400\mu\text{m}/\pm 40\mu\text{m}/\pm 4\text{mm}$  ( $\pm 5\text{mm}$ : tracking range)  
 Measuring force: 40mN (not adjustable)  
 Standard stylus: **12AAE301**, carbide ball,  $\varnothing 1.6\text{mm}$   
 Measuring direction: one direction  
 Stylus angle adjustment:  $\pm 45^\circ$  (with graduations)

Air supply  
 Air pressure: 390kPa (4kgf/cm<sup>2</sup>)  
 Air consumption: 30L/min.  
 Power supply: 100V AC – 240V AC, 50/60Hz  
 Dimensions (W x D x H): 26.3 x 20 x 35.4"  
 (667 x 510 x 900mm)  
 (26.3 x 20 x 43.3"  
 (667 x 510 x 1100mm): 2200H model)  
 Mass: 397 lbs (180kg) 441 lbs (200kg): 2200H model)

## Technical Data: RA-H5200CNC

Turntable  
 Rotational accuracy (radial):  $\{(8+.35H)\mu\text{in}\}$   $\{(0.02+3.5H/10000)\mu\text{m}\}$   
 Rotational accuracy (axial):  $\{(8+.35X)\mu\text{in}\}$   $\{(0.02+3.5X/10000)\mu\text{m}\}$   
H: Probing height (mm), X: Distance from the turntable axis (mm)  
 Rotating speed: 2, 4, 6, 10rpm (20rpm: auto-centering)  
 Table top diameter:  $\varnothing 300\text{mm}$   
 Centering range:  $\pm 5\text{mm}$   
 Leveling range:  $\pm 1^\circ$   
 Maximum probing diameter:  $\varnothing 14"$  (356mm)  
 Maximum workpiece diameter:  $\varnothing 26.8"$  (680mm)  
 Maximum workpiece weight: 176 lbs (80kg)  
 143 lbs (65kg): auto-centering

Vertical column (Z-axis)  
 Vertical travel: 13.7" (350mm) 21.7" (550mm): H5200H model  
 Straightness ( $\lambda$ c2.5): 0.05 $\mu\text{m}$  / 100mm, 0.14 $\mu\text{m}$  / 350mm  
 (0.2 $\mu\text{m}$  / 550mm: H5200H model)  
 Parallelism with rotating axis: 0.2 $\mu\text{m}$  / 350mm  
 (0.32 $\mu\text{m}$  / 550mm: H5200H model)  
 Positioning speed: Max. 60mm/s  
 Measuring speed: 0.5, 1, 2, 5mm/s  
 Maximum probing height: 13.7" (350mm) (OD / ID)  
 [21.7" (550mm) (OD / ID): H5200H model]  
 Maximum probing depth: over  $\varnothing 32$ : 104mm (w/standard stylus)  
 over  $\varnothing 12.7$ : 26mm (w/standard stylus)

Horizontal arm (X-axis)  
 Horizontal travel: 8.8" (225mm)  
 Straightness ( $\lambda$ c2.5): 0.4 $\mu\text{m}$  / 200mm  
 Squareness with rotating axis: 0.5 $\mu\text{m}$  / 200mm  
 Positioning speed: Max. 50mm/s  
 Measuring speed: 0.5, 1, 2, 5mm/s

Probe and stylus  
 Measuring range:  $\pm 400\mu\text{m}$  ( $\pm 5\text{mm}$ : tracking range)  
 Measuring force: 40mN (not adjustable)  
 Standard stylus: **12AAE301**, carbide ball,  $\varnothing 1.6\text{mm}$   
 Measuring direction: one direction  
 Stylus angle adjustment:  $\pm 45^\circ$  (with graduations)

Air supply  
 Air pressure: 390kPa (4kgf/cm<sup>2</sup>)  
 Air consumption: 45L/min.  
 Power supply: 100V AC – 240V AC, 50/60Hz  
 Dimensions (W x D x H): 49.6 x 28.0 x 66.9"  
 (1260 x 710 x 1700mm)  
 49.6 x 28.0 x 74.8"  
 (1260 x 710 x 1900mm: H5200H model)  
 Mass: Main unit: 1433 lbs (650kg)  
 1477 lbs (670kg): H5200H (model)  
 Vibration isolator: 375 lbs (170kg)

# Roundtest Extreme RA-2200CNC / RA-H5200CNC

## SERIES 211 — CNC Roundness, Cylindricity and Surface Roughness Measuring System

Mitutoyo offers innovative roundness/cylindricity measuring systems capable of automated measurement with independent/simultaneous multi-axis CNC control. In addition to high measuring accuracy and reliability, these CNC models provide excellent inspection productivity. Roundness and surface roughness measurements are both available from a single measuring system so workpiece resetting for roughness measurement is not required. Roughness measurement is possible in the axial and circumferential directions.



Holder-arm orientation switching (vertical position - horizontal position)



Detector rotation mechanism (0 to 290°, in increments of 1°)



**RA-2200H CNC**  
with personal computer system and software

\* Shown with optional vibration isolator and side table for PC.



**RA-H5200H CNC**  
with personal computer system and software

\* Shown with optional side table for PC.

**Mitutoyo**

# Roundtest Extreme RA-2200CNC / RA-H5200CNC

## SERIES 211 — CNC Roundness, Cylindricity and Surface Roughness Measuring System

### ROUNDPAK

#### Off-line measurement procedure programming function

On-screen virtual 3D simulation measurements can be performed with the incorporated off-line teaching function that allows a part program (measurement procedure) to be created without an objective workpiece. The probe and the holder unit of the Roundtest Extreme can be precisely represented and an alarm can be raised to indicate that there is a collision risk predicted by the simulation.



3D simulation screens (work-view windows) can be generated after entering CAD data (in IGES, DXF form) and text data.

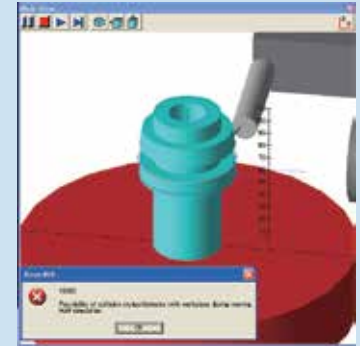
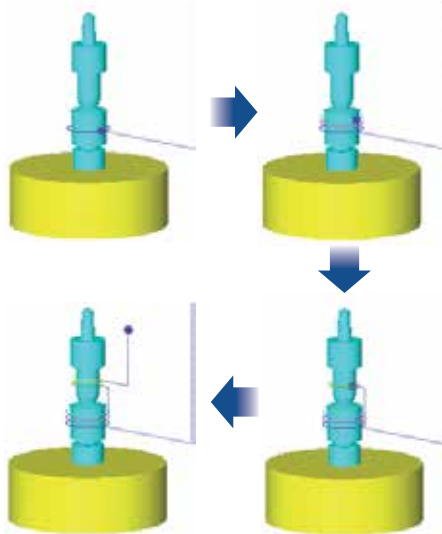

### SPECIFICATIONS

Model No.	EXTREME RA-2200S CNC	EXTREME RA-2200H CNC
Order No.	<b>211-517A</b>	<b>211-518A</b>
Column travel	11.8" (300mm) (standard column)	19.7" (500mm) (high column)

Model No.	EXTREME RA-H5200S CNC	EXTREME RA-H5200H CNC
Order No. with vibration isolating stand	<b>211-533A</b>	<b>211-534A</b>
Column travel	13.77" (350mm) (standard column)	21.65" (550mm) (high column)

### DIMENSIONS

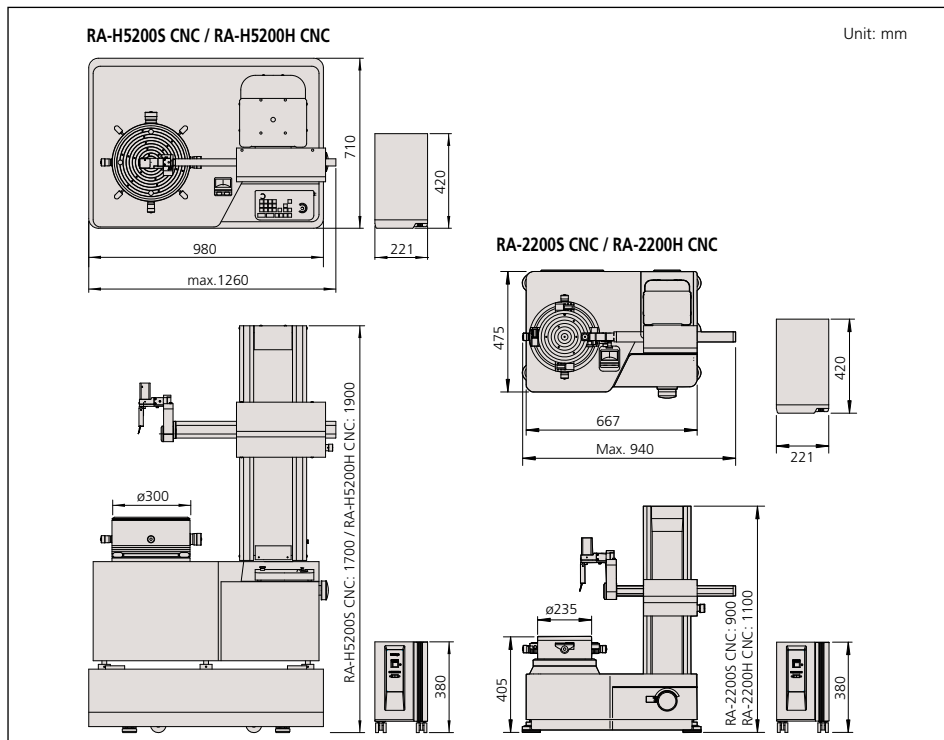

### Optional Accessories

- 350850:** Cylindrical square
- 211-045:** Magnification calibration gage
- 211-014:** Chuck (OD: 1 - 78mm, ID: 25 - 68mm)
- 211-032:** Quick chuck (OD: 1 - 79mm, ID: 16 - 69mm)
- 211-031:** Micro-chuck (OD: 0.1~1.5mm max.)
- 12AAB598:** Protective shield (RA-H5200 only)
- Interchangeable styli (See page J-49.)
- 12AAK110:** Vibration isolator (RA-2200 only)
- 12AAK120:** Monitor arm (RA-2200 only)
- 12AAL019:** Side table for PC
- 12AAG419:** Surface roughness detector for RA-CNC



### Dimensions

Overall: 36 x 30 x 24-32" (W x D x H)  
 Cord Bin: 4" h x 5-3/8" d (width is 10" less than table width)  
 Distance From Front Edge to Cord Bin: 30" d table - 15-1/2" d  
 Distance Between Legs: 10" less than the overall table width

Work surface feature a 1", 45 lb density, furniture board substrate with attractive Gray laminate tabletop brimmed with bullnose edge band in Quartz gray color. Work surface is height adjustable in one inch increments from 24" to 32".

Tabletop incorporates metal threaded inserts on the underside to affix the leg assemblies for added strength and durability. Table comes with 4" casters with two as locking type for stationary placement.

\*Laptop PC not included with table.



# Optional Styli for Roundtest

## Interchangeable Styli for RA-120, RA-120P, RA-1600/M, RA-2200, RA-H5200

Application/Type	Standard (Standard accessory)	Notch	Deep groove	Corner	Cutter mark
Order No.	<b>12AAL021*</b>	<b>12AAL022</b>	<b>12AAL023</b>	<b>12AAL024</b>	<b>12AAL025</b>
Stylus tip	ø1.6 mm tungsten carbide	ø3 mm tungsten carbide	SR0.25mm sapphire	SR0.25mm sapphire	tungsten carbide
Dimensions (mm)					
Application/Type	Small hole (ø0.8)	Small hole (ø1.0)	Small hole (ø1.6)	Extra small hole (Depth 3mm)	ø1.6 mm ball
Order No.	<b>12AAL026</b>	<b>12AAL027</b>	<b>12AAL028</b>	<b>12AAL029</b>	<b>12AAL030</b>
Stylus tip	ø0.8 mm tungsten carbide	ø1 mm tungsten carbide	ø1.6 mm tungsten carbide	ø0.5 mm tungsten carbide	ø1.6 mm tungsten carbide
Dimensions (mm)					
Application/Type	Disk	Crank (ø0.5)	Crank (ø1.0)	Flat surface	2X-long type**
Order No.	<b>12AAL031</b>	<b>12AAL032</b>	<b>12AAL033</b>	<b>12AAL034</b>	<b>12AAL035</b>
Stylus tip	ø12 mm tungsten carbide	ø0.5 mm tungsten carbide (Depth 2.5 mm)	ø1 mm tungsten carbide (Depth 5.5 mm)	tungsten carbide	ø1.6 mm tungsten carbide
Dimensions (mm)					
Application/Type	2X-long type notch**	2X-long type deep groove**	2X-long type corner**	2X-long type cutter mark**	2X-long type Small hole**
Order No.	<b>12AAL036</b>	<b>12AAL037</b>	<b>12AAL038</b>	<b>12AAL039</b>	<b>12AAL040</b>
Stylus tip	ø3 mm tungsten carbide	SR0.25 mm sapphire	SR0.25 mm sapphire	tungsten carbide	ø1 mm tungsten carbide
Dimensions (mm)					
Application/Type	3X-long type**	3X-long type deep groove**	Stylus shank	Stylus shank (standard groove)	Stylus shank (2X-long groove)**
Order No.	<b>12AAL041</b>	<b>12AAL042</b>	<b>12AAL043</b>	<b>12AAL044</b>	<b>12AAL045</b>
Stylus tip	ø1.6 mm tungsten carbide	SR0.25 mm sapphire	For mounting CMM stylus (mounting thread M2)	For mounting CMM stylus (mounting thread M2)	For mounting CMM stylus (mounting thread M2)
Dimensions (mm)					

\* 12AAL021 is a standard accessory for all Roundtest models.

\*\* Not available for RA-10, RA-120P and RA-220

Measuring is only in the vertical direction. Measuring magnification of 20000X is available using the 2X-long stylus.

Customized special interchangeable styli are available on request. Please contact any Mitutoyo office for more information.

† New design for holding styli is not shown in above illustrations.

New styli for RA-2200 / H5200 are compatible with old RA-2100 / H5100 detectors.

Old styli for RA-2100 / H5100 are NOT compatible with new RA-2200 / H5200 detectors.

### 5 pc. Stylus set: 12AAL020

Part No.	Part Description
12AAL022	Stylus for notched workpiece
12AAL023	Stylus for deep groove
12AAL027	Stylus for small hole (1.0mm)
12AAL030	1.6mm ball stylus
12AAL035	2X-long type stylus

### M2 CMM stylus with ruby ball tip

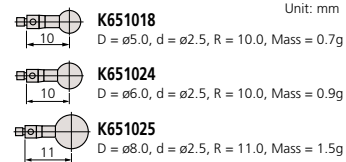
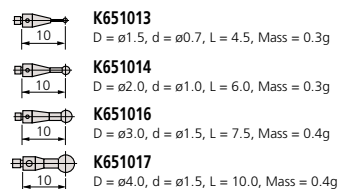
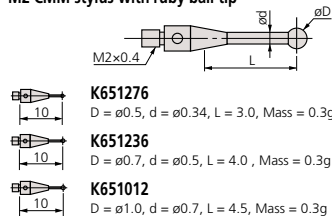

# Optional Styli for Roundtest

## Interchangeable Styli for RA-2200 CNC, RA-H5200 CNC

Application/Type	Groove	Flat surface	General purpose	Notch
Order No.	<b>12AAE310</b>	<b>12AAE302</b>	<b>12AAE301</b>	<b>12AAE309</b>
Stylus tip	ø1.6 mm tungsten carbide	ø1.6 mm tungsten carbide	ø1.6 mm tungsten carbide	ø3 mm tungsten carbide
Dimensions (mm)				
Application/Type	ø1.6 mm ball	ø0.8 mm ball	ø0.5 mm ball	Deep groove
Order No.	<b>12AAE303</b>	<b>12AAE304</b>	<b>12AAE305</b>	<b>12AAE308</b>
Stylus tip	ø1.6 mm tungsten carbide	ø0.8 mm tungsten carbide	ø0.5 mm tungsten carbide	ø1.6 mm tungsten carbide
Dimensions (mm)				
Application/Type	Deep hole A		Deep hole B	
Order No.	<b>12AAE306</b>		<b>12AAE307</b>	
Stylus tip	ø1.6 mm tungsten carbide		ø1.6 mm tungsten carbide	
Dimensions (mm)				

Analysis options		RA-H5200CNC/ RA-H5200	RA-2200CNC/ RA-2200	RA-1600	RA-1600M	RA-120P	RA-120
Roundness	○	●	●	●	●	●	●
Cylindricity	∅	●	●	●	●	—	—
Concentricity	◎	●	●	●	●	●	●
Coaxiality	axis-element	●	●	●	●	●	●
	Axis-axis	●	●	●	●	●	—
Flatness	▭	●	●	●	▲	●	●
Parallelism	//	●	●	●	▲	●	●
Perpendicularity	⊥	●	●	●	●	●	●
Runout	↗	●	●	●	●	●	●
Total runout	↗↖	●	●	●	▲	—	—
Straightness	—	●	●	●	▲	—	—
Inclination	/	●	●	●	▲	—	—
Taper	/\	●	●	●	▲	—	—

- Full measurement capability
- ▲ Limited measurement capability; R-Axis must be stationary.

### Usage examples of styli

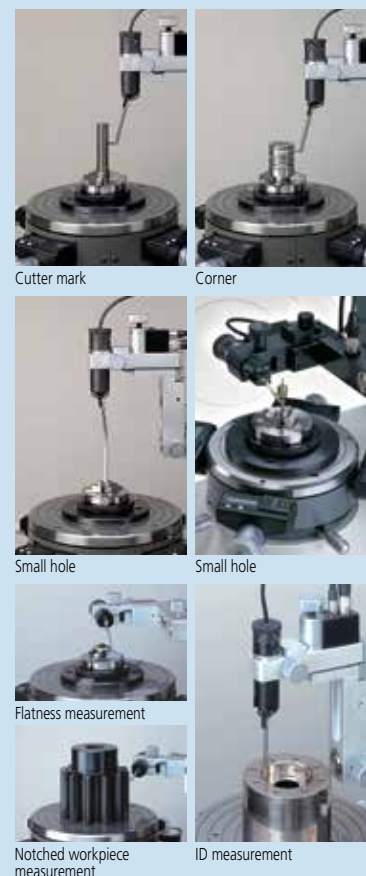

# Optional Accessories for Roundtest



## Centering chuck (ring operated) 211-032

Suitable for holding small parts with easy-to-operate knurled-ring clamping.

- Holding capacity:  
Internal jaws: OD = 1-36 mm, ID = 14-70 mm.  
External jaws: OD = 1-75 mm.
- External dimensions:  $\phi 118 \times 41$  mm
- Mass: 1.2kg



## Micro-chuck 211-031

Used for clamping a workpiece (less than  $\phi 1$  mm dia.) that the centering chuck cannot handle.

- Holding capacity: up to  $\phi 1.5$  mm
- External dimensions:  $\phi 118 \times 48.5$  mm
- Mass: 0.8kg



## Centering chuck (key operated) 211-014

Suitable for holding longer parts and those requiring a relatively powerful clamp.

- Holding capacity:  
Internal jaws: OD = 1 - 35mm, ID = 33 - 85mm  
External jaws: OD = 30-80mm.
- External dimensions:  $\phi 157 \times 76$ mm
- Mass: 3.8kg



## Magnification calibration gage 211-045

Used for normalizing detector magnification by calibrating detector travel against displacement of a micrometer spindle.

- Maximum calibration range: 400 $\mu$ m
- Graduation: 0.2 $\mu$ m
- Mass: 4kg

## Vibration Isolated frame with work surface



Code No.	Dimensions	Load Capacity
64AAB357	30 x 48 x 30"	1300 lbs

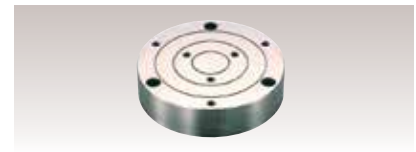

## Auxiliary workpiece stand 356038

- Used for measuring a workpiece whose diameter is 20mm or shorter and whose height is 20mm or lower.



211-016  
Reference Hemisphere



## Cylindrical square 350850

- Used for checking and aligning table rotation axis parallel to the Z-axis column.
- Squareness: 3 $\mu$ m
- Straightness: 1 $\mu$ m
- Cylindricity: 2 $\mu$ m
- Roundness: 0.5 $\mu$ m
- Mass: 7.5kg

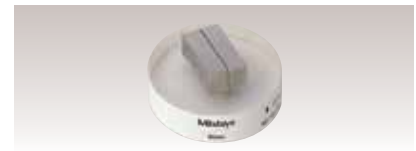

## Magnification checking kit\* 997090

- A combination of gage blocks and an optical flat.
- \* Standard accessory for RA-2200, RA-2200CNC, RA-H5200 and RA-H5200CNC



## Origin-point gage\* 998382

- A gage for zero setting of the R-axis and Z-axis.
- \* Standard accessory for RA-2200 and RA-H5200

# Eco-Fix Kit Form-S

## Mitutoyo ECO-FIX Kit Fixture Systems



Part No.	Qty.	Part name	Part No.	Qty.	Part name
K551038	1	Adaptor plate ø 150mm	K551069	1	Flat top ø 12mm
K551024	1	Location pin ø 12 X 13mm	K550262	1	V-block mini
K551025	1	Location pin ø 12 X 25mm	K550261	2	Cone receiver mini
K551026	1	Location pin ø 12 X 50mm	K550250	1	Stopper element mini
K551027	1	Location pin ø 12 X 100mm	K550247	1	Back square mini
K551028	1	Location pin ø 20 X 13mm	K550888	2	Straight pin Ø 6mm x 20mm
K551029	1	Location pin ø 20 X 25mm	K550889	2	Straight pin Ø 6mm x 30mm
K551030	1	Location pin ø 20 X 50mm	K550890	2	Straight pin Ø 6mm x 40mm
K551031	1	Location pin ø 20 X 100mm	K551046	1	Slotted nut for receiver bracket h=12mm
K551035	1	Receiver bracket small	K551050	1	Allen key 2mm
K551036	1	Receiver bracket large	K551051	1	Allen key 3mm
K551040	1	Adjustable location pin ø 20mm	K551052	1	Allen key 4mm
K551041	1	Adjustable location pin ø 12mm	K551053	1	Allen key 5mm
K551042	3	Location pin ø 12mm with bore ø 6mm	K551054	1	Double open ended spanner 10-17
K551044	1	Receiver bracket L=90; ø 12mm	K550591	1	Washer ø 6,4mm / ø 17mm
K550716	1	Straight pin with thread	K550110	8	Cylinder head screw M6 x 20mm
K550279	1	Spring clip, d= 8mm, L= 60mm	K550563	6	Cylinder head screw M6 x 25mm
Kit Part No.			K551133		



# Eco-Fix Kit Form-L



Part No.	Qty.	Part name	Part No.	Qty.	Part name
K551039	1	Adaptor plate ø 200mm	K550247	1	Back square mini
K551024	1	Location pin ø 12 X 13mm	K550058	1	V-block
K551025	1	Location pin ø 12 X 25mm	K550365	2	Cone receiver
K551026	1	Location pin ø 12 X 50mm	K550982	1	Stopper element
K551027	2	Location pin ø 12 X 100mm	K550248	1	Back square
K551028	2	Location pin ø 20 X 13mm	K550888	2	Straight pin Ø 6mm x 20mm
K551029	2	Location pin ø 20 X 25mm	K550889	2	Straight pin Ø 6mm x 30mm
K551030	2	Location pin ø 20 X 50mm	K550890	2	Straight pin Ø 6mm x 40mm
K551031	1	Location pin ø 20 X 100mm	K550000	2	Straight pin Ø 8mm x 30mm
K551035	1	Receiver bracket small	K550001	2	Straight pin Ø 8mm x 50mm
K551036	1	Receiver bracket large	K550002	2	Straight pin Ø 8mm x 95mm
K551040	2	Adjustable location pin ø 20mm	K551046	1	Slotted Nut for receiver bracket h= 12mm
K551041	1	Adjustable location pin ø 12mm	K551047	1	Slotted Nut for receiver bracket h= 15mm
K551042	2	Location pin ø 12mm with bore ø 6mm	K551050	1	Allen key 2mm
K551043	3	Location pin ø 20mm with bore ø 8mm	K551051	1	Allen key 3mm
K551044	1	Receiver bracket L=90; ø 12mm	K551052	1	Allen key 4mm
K551045	1	Receiver bracket L=120; ø 20mm	K551053	1	Allen key 5mm
K550279	2	Spring clip, d= 8mm, L= 60mm	K550591	1	Washer ø 6,4mm / ø 17mm
K550262	1	V-block mini	K550110	12	Cylinder head screw M6 x 20mm
K550261	2	Cone receiver mini	K550563	6	Cylinder head screw M6 x 25mm
K550250	1	Stopper element mini			
Kit Part No.			K551134		



# Quick Guide to Precision Measuring Instruments

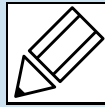

## Roundtest (Roundform Measuring Instruments)

- JIS B 7451-1997: Roundness measuring instruments
- JIS B 0621-1984: Definition and notation of geometric deviations
- JIS B 0021-1998: Geometric property specifications touching of products – Geometric tolerance Roundness Testing

### ○ Roundness

Any circumferential line must be contained within the tolerance zone formed between two coplanar circles with a difference in radii of  $t$

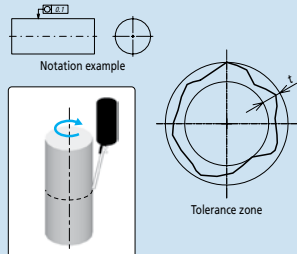

Verification example using a roundness measuring instrument

### — Straightness

Any line on the surface must lie within the tolerance zone formed between two parallel straight lines a distance  $t$  apart and in the direction specified

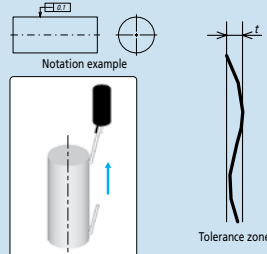

Verification example using a roundness measuring instrument

### □ Flatness

The surface must be contained within the tolerance zone formed between two parallel planes a distance  $t$  apart

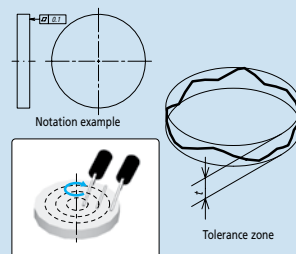

Verification example using a roundness measuring instrument

### ○/Cylindricity

The surface must be contained within the tolerance zone formed between two coaxial cylinders with a difference in radii of  $t$

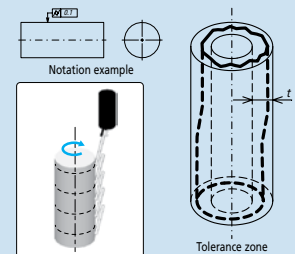

Verification example using a roundness measuring instrument

### ◎ Concentricity

The center point must be contained within the tolerance zone formed by a circle of diameter  $t$  concentric with the datum

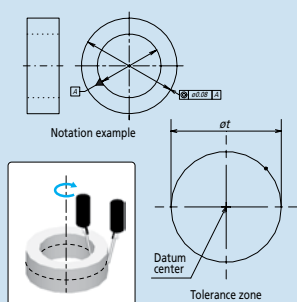

Verification example using a roundness measuring instrument

### ◎ Coaxiality

The axis must be contained within the tolerance zone formed by a cylinder of diameter  $t$  concentric with the datum

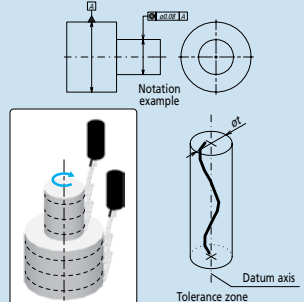

Verification example using a roundness measuring instrument

### ⊥ Perpendicularity

The line or surface must be contained within the tolerance zone formed between two planes a distance  $t$  apart and perpendicular to the datum

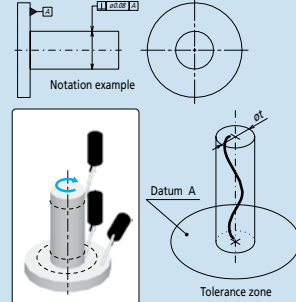

Verification example using a roundness measuring instrument

### ◎/Cylindricity

The surface must be contained within the tolerance zone formed between two coaxial cylinders with a difference in radii of  $t$

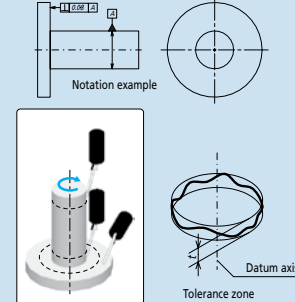

Verification example using a roundness measuring instrument

### ↻ Circular Runout

The line must be contained within the tolerance zone formed between two coplanar and/or concentric circles a distance  $t$  apart concentric with or perpendicular to the datum

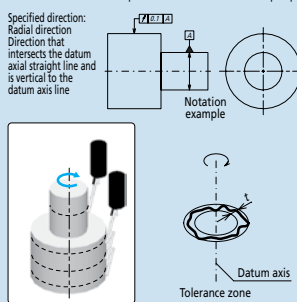

Verification example using a roundness measuring instrument

### ↻ Total Runout

The surface must be contained within the tolerance zone formed between two coaxial cylinders with a difference in radii of  $t$ , or planes a distance  $t$  apart, concentric with or perpendicular to the datum

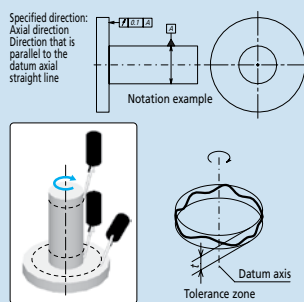

Verification example using a roundness measuring instrument

### ↻ Total Runout

The surface must be contained within the tolerance zone formed between two coaxial cylinders with a difference in radii of  $t$ , or planes a distance  $t$  apart, concentric with or perpendicular to the datum

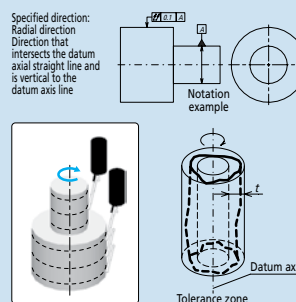

Verification example using a roundness measuring instrument

### ↻ Total Runout

The surface must be contained within the tolerance zone formed between two coaxial cylinders with a difference in radii of  $t$ , or planes a distance  $t$  apart, concentric with or perpendicular to the datum

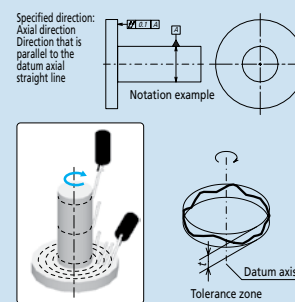

Verification example using a roundness measuring instrument

## ■ Adjustment prior to Measurement

### Centering

A displacement offset (eccentricity) between the Roundtest's rotary table axis and that of the workpiece results in distortion of the measured form (limaçon error) and consequentially produces an error in the calculated roundness value. The larger the eccentricity, the larger is the error in calculated roundness. Therefore the workpiece should be centered (axes made coincident) before measurement. Some roundness testers support accurate measurement with a limaçon error correction function. The effectiveness of this function can be seen in the graph below.

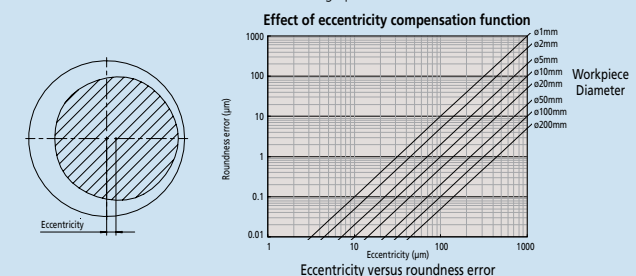

### Leveling

Any inclination of the axis of a workpiece with respect to the rotational axis of the measuring instrument will cause an elliptic error. Leveling must be performed so that these axes are sufficiently parallel.

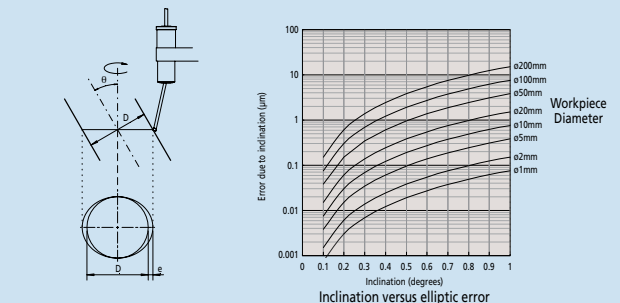

## Effect of Filter Settings on the Measured Profile

Roundness values as measured are greatly affected by variation of filter cutoff value. It is necessary to set the filter appropriately for the evaluation required.



## Evaluating the Measured Profile Roundness

Roundness testers use the measurement data to generate reference circles whose dimensions define the roundness value. There are four methods of generating these circles, as shown below, and each method has individual characteristics so the method that best matches the function of the workpiece should be chosen.

### Least Square Circle (LSC) Method

A circle is fitted to the measured profile such that the sum of the squares of the departure of the profile data from this circle is a minimum. The roundness figure is then defined as the difference between the maximum departures of the profile from this circle (highest peak to the lowest valley).

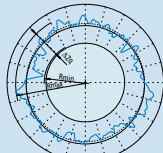

$$\Delta Zq = R_{max} - R_{min}$$

### Minimum Zone Circles (MZC) Method

Two concentric circles are positioned to enclose the measured profile such that their radial difference is a minimum. The roundness figure is then defined as the radial separation of these two circles.

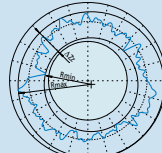

$$\Delta Zq = R_{max} - R_{min}$$

### Minimum Circumscribed Circle (MCC) Method

The smallest circle that can enclose the measured profile is created. The roundness figure is then defined as the maximum departure of the profile from this circle. This circle is sometimes referred to as the 'ring gage' circle.

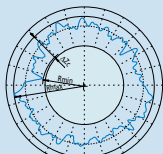

$$\Delta Zc = R_{max} - R_{min}$$

### Maximum Inscribed Circle (MIC) Method

The largest circle that can be enclosed by the profile data is created. The roundness figure is then defined as the maximum departure of the profile from this circle. This circle is sometimes referred to as the 'plug gage' circle.

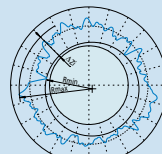

$$\Delta Zi = R_{max} - R_{min}$$

## Undulations Per Revolution (UPR) data in the roundness graphs

### Measurement result graphs

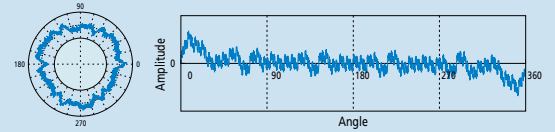

A 1 UPR condition indicates eccentricity of the workpiece relative to the rotational axis of the measuring instrument. The amplitude of undulation components depends on the leveling adjustment.

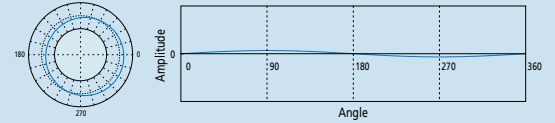

A 2 UPR condition may indicate: (1) insufficient leveling adjustment on the measuring instrument; (2) circular runout due to incorrect mounting of the workpiece on the machine tool that created its shape; (3) the form of the workpiece is elliptical by design as in, for example, an IC-engine piston.

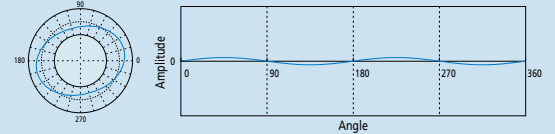

A 3 to 5 UPR condition may indicate: (1) Deformation due to over-tightening of the holding chuck on the measuring instrument; (2) Relaxation deformation due to stress release after unloading from the holding chuck on the machine tool that created its shape.

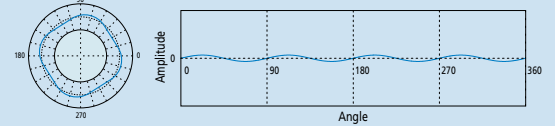
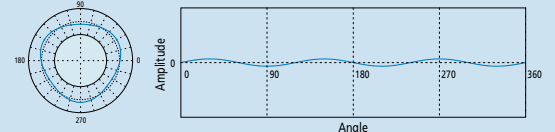

A 5 to 15 UPR condition often indicates unbalance factors in the machining method or processes used to produce the workpiece.

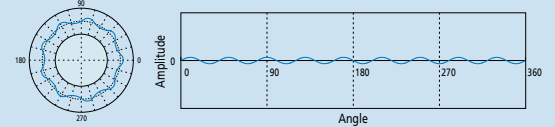
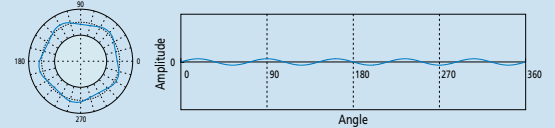

A 15 (or more) UPR condition is usually caused by tool chatter, machine vibration, coolant delivery effects, material non-homogeneity, etc., and is generally more important to the function than to the fit of a workpiece.

