

Basic Rules on Using Measuring Tools

TEXTBOOK

Mitutoyo

CONTENTS

MICROMETERS	1
CALIPERS	4
HEIGHT GAGES	8
DIAL INDICATORS	11
DIAL TEST INDICATORS	14
BORE GAGES	17

MICROMETERS

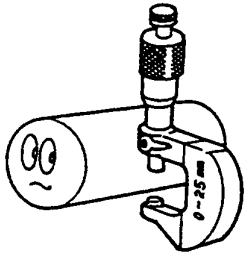
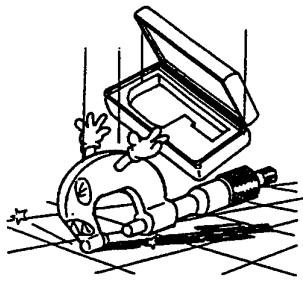
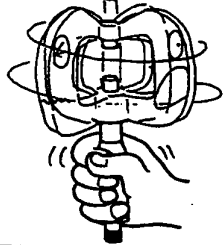
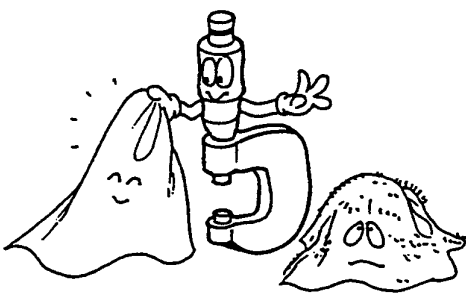
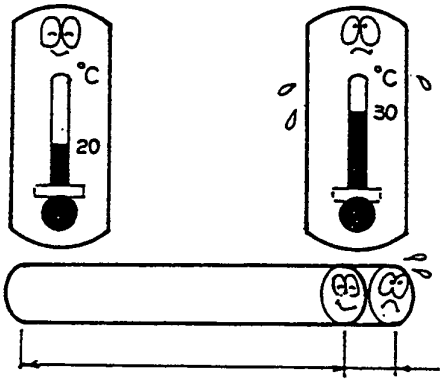
<p>1</p>	<p>Select the micrometer that best fits the application.</p> <ul style="list-style-type: none"> • Make sure that the type, measuring range, graduation and other specifications of the micrometer are appropriate for your application. 	
<p>2</p>	<p>Do not apply excessive force to the micrometer.</p> <ul style="list-style-type: none"> • Do not drop or give sharp blows to the micrometer. • Do not spin the micrometer violently. 	 
<p>3</p>	<p>Wipe off any dust from the micrometer before use.</p> <ul style="list-style-type: none"> • Thoroughly wipe the spindle and the measuring faces. Use only lint free paper or cloth. 	
<p>4</p>	<p>Leave the micrometer and the workpiece in the room long enough to adjust to room temperature.</p> <ul style="list-style-type: none"> • A 100 mm (4") long iron rod will change by 0.012 (.00047") mm with a temperature change of 10°C. 	

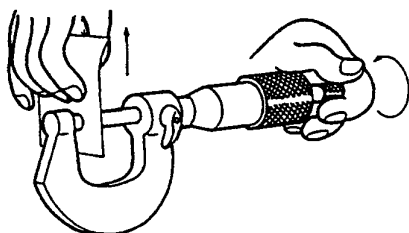
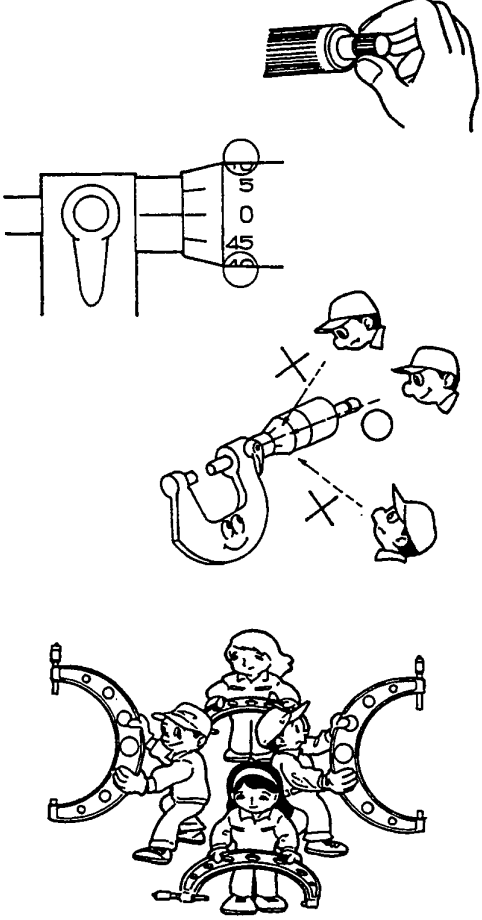
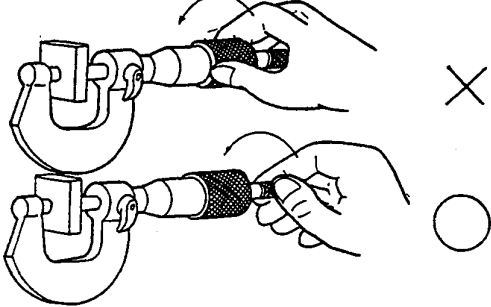
<p>5</p>	<p>Before use, clean the anvil and spindle faces.</p> <ul style="list-style-type: none"> • Use only lint-free paper to wipe the measuring faces. 	
<p>6</p>	<p>Adjust the zero line.</p> <ul style="list-style-type: none"> • Bring the measuring faces together using only the ratchet stop or friction thimble. • Read the thimble graduations directly from the front (where numerals 10 and 40 appear the same size). • If the zero line on the thimble does not line up with the index line on the sleeve, turn the sleeve to make the two lines coincide with each other. <ul style="list-style-type: none"> • When the measuring length exceeds 300mm (12"); adjust the zero line with the micrometer in the same position it will be in when measuring. 	
<p>7</p>	<p>Always use the ratchet stop or friction thimble when measuring.</p>	

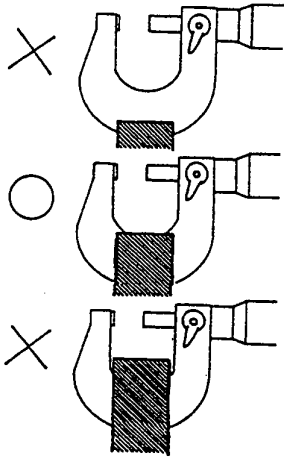
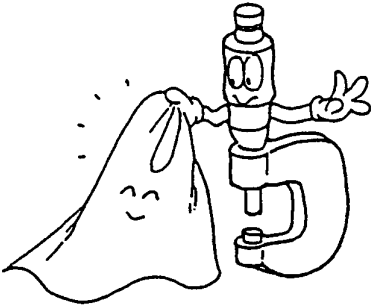
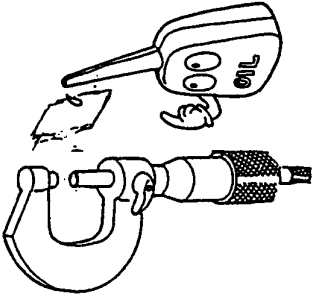
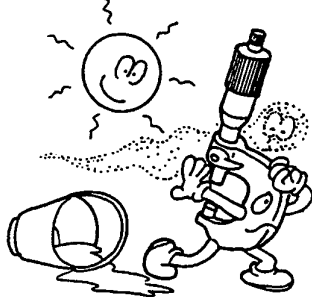
8	<p>When mounting the micrometer on a stand, ensure that the micrometer frame is clamped at the center. Do not clamp it too tightly.</p>	
9	<p>After use, wipe dirt and fingerprints from the micrometer with a soft, dry cloth.</p>	
10	<p>When storing the micrometer for long periods of time or when it needs oil, use a cloth dampened with rust preventive oil and lightly wipe each section (except for the carbide sections) of the micrometer. Make sure that the oil is spread evenly over the surfaces.</p>	
11	<p>The following points should be kept in mind when storing micrometers.</p> <ul style="list-style-type: none"> • Do not expose the micrometer to direct sunlight. • Store the micrometer in a low humidity and well ventilated environment. • Store the micrometer in a dust free environment. • Do not place the micrometer directly on the floor. • Leave the measuring faces separated between 0.1 to 1 mm (.004" to .04"). • Do not clamp the spindle. • Store the micrometer in a case. 	

CALIPERS

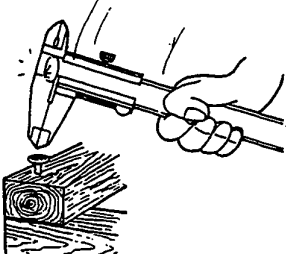
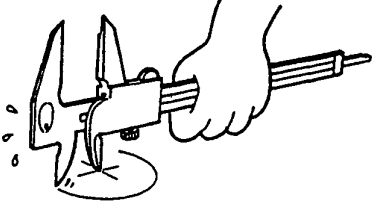
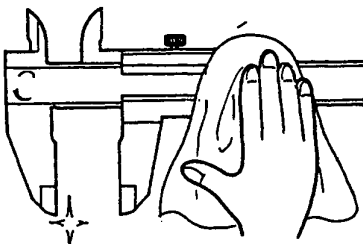
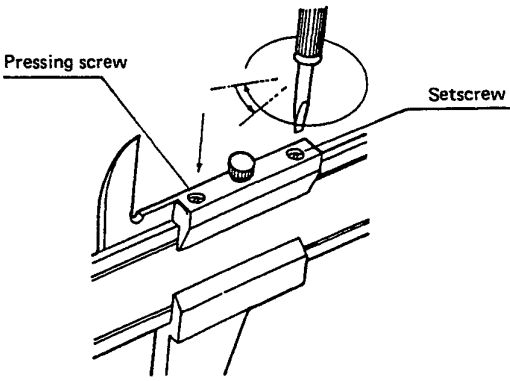
1	<p>Select the caliper that best fits the application.</p> <ul style="list-style-type: none">• Make sure that the type, measuring range, graduation and other specifications of the caliper are appropriate for your application.	
2	<p>Do not apply excessive force to the caliper.</p> <ul style="list-style-type: none">• Do not drop or give sharp blows to the caliper.• Do not use the caliper for a hammer.	
3	<p>Be careful not to damage the inside measurement jaws.</p> <ul style="list-style-type: none">• Do not use the jaws for a compass or a divider.	
4	<p>Wipe off any dust from the caliper before use.</p> <ul style="list-style-type: none">• Thoroughly wipe the sliding surfaces and measuring faces. Use only lint free paper or cloth.	
5	<p>Check the slider movement for smoothness. It should not feel loose or have any play. Correct any problems found by adjusting the pressing screw and setscrew.</p> <ul style="list-style-type: none">• Tighten the pressing screw and setscrew, then loosen them in a counterclockwise direction about 1/8 of a turn (45°).• Check the sliding smoothness again.• Repeat the above procedure while adjusting the angular position of the screws until an appropriate sliding smoothness is obtained.	 <p>Pressing screw</p> <p>Setscrew</p>

6

Outside measurement :

- Hold and measure the workpiece in a position as close to the reference surface as possible.
- Make sure the faces of the outside measurement jaws are in even contact with the workpiece.

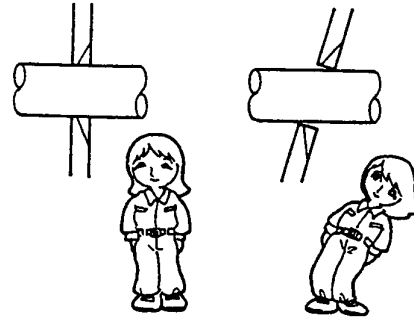
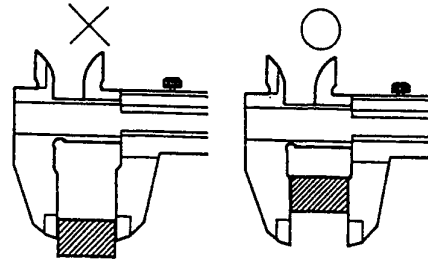

7

Inside measurement :

Take your measurement when the inside measurement jaws are as deep inside the workpiece as possible.

- When measuring an inside diameter, read the scale when the indicated value is at its maximum.
- When measuring the groove width, read the scale when the indicated value is at its minimum.

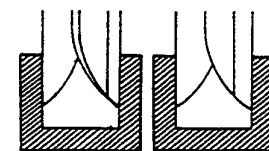
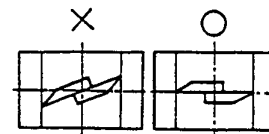
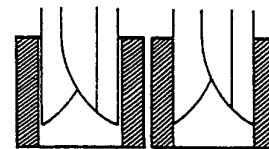
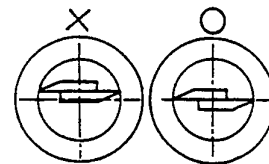
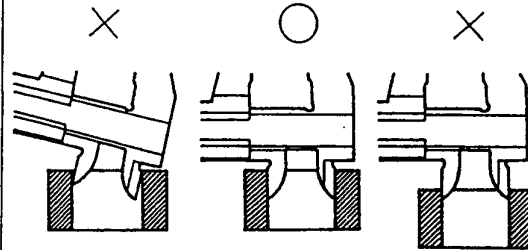

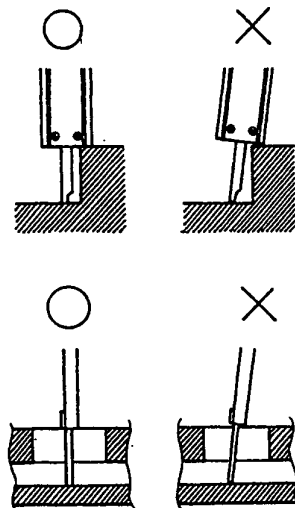
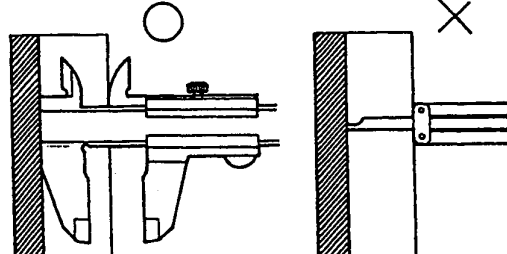
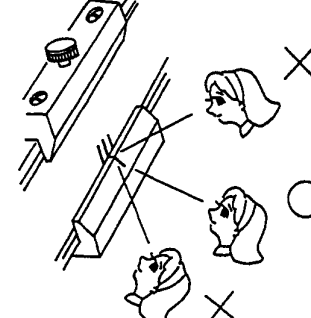
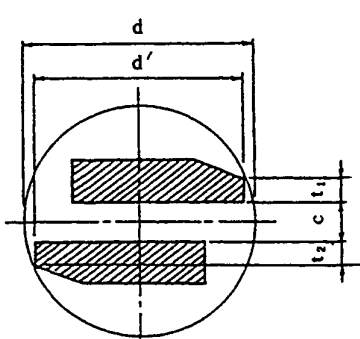
8	<p>Depth measurement</p> <ul style="list-style-type: none"> • Take your measurement when the bottom face of the main scale the workpiece is in even contact with the workpiece. 									
9	<p>Step measurement</p> <ul style="list-style-type: none"> • Take your measurement when the step measuring face is in even contact with the work piece. 									
10	<p>Avoid parallax errors by reading the scale directly from the front.</p>									
11	<p>Measurements of small-diameter holes are indicated somewhat smaller than the actual diameter.</p> <p>Error when measuring a workpiece whose bore diameter is 5 mm:</p> <p style="text-align: center;">Unit : mm (inch)</p> <table border="1" data-bbox="292 1638 812 1785"> <thead> <tr> <th>$t_1 + t_2 + C$</th> <th>0.3 (.001)</th> <th>0.5 (.019)</th> <th>0.7 (.027)</th> </tr> </thead> <tbody> <tr> <td>Δd</td> <td>0.009 (.0003)</td> <td>0.026 (.001)</td> <td>0.047 (.002)</td> </tr> </tbody> </table>	$t_1 + t_2 + C$	0.3 (.001)	0.5 (.019)	0.7 (.027)	Δd	0.009 (.0003)	0.026 (.001)	0.047 (.002)	 $\Delta d = d - d' = d - \sqrt{d^2 - (t_1 + c + t_2)^2}$
$t_1 + t_2 + C$	0.3 (.001)	0.5 (.019)	0.7 (.027)							
Δd	0.009 (.0003)	0.026 (.001)	0.047 (.002)							

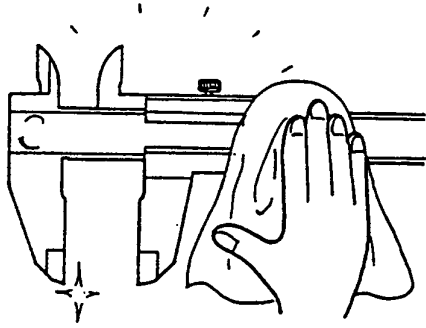
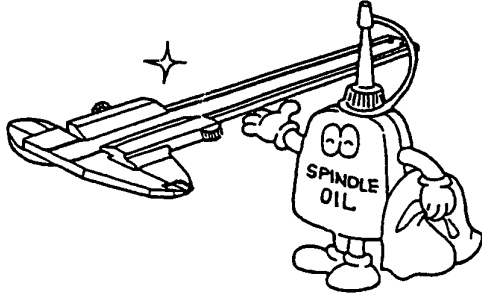
12	<p>After use, wipe dirt and finger prints from the caliper with a soft, dry cloth.</p>	
13	<p>When storing the caliper for long periods of time or when it needs oil, use a cloth dampened with rust preventive oil and lightly wipe each section of the caliper. Make sure that the oil is spread evenly over the surfaces.</p>	
14	<p>The following points should be kept in mind when storing calipers.</p> <ul style="list-style-type: none"> • Do not expose the caliper to direct sunlight. • Store the caliper in a low humidity and well ventilated environment. • Store the caliper in a dust free environment. • Do not place the caliper directly on the floor. • Leave the measuring faces separated between 0.2 to 2 mm (.008" to .08"). • Do not clamp the slider. • Store the caliper in a case (or plastic bag). 	

HEIGHT GAGES

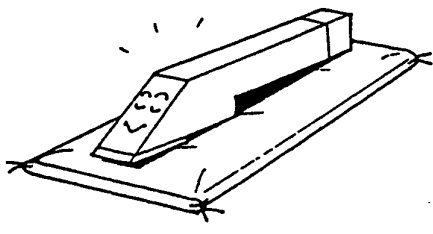
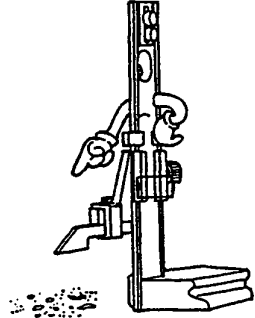
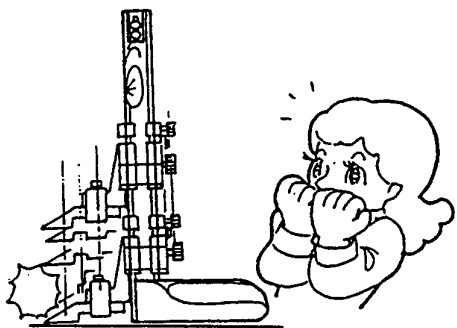
1	<p>Select the height gage that best fits the application.</p> <ul style="list-style-type: none">• Make sure that the type, measuring range, graduation and other specifications of the height gage are appropriate for your application.	
2	<p>Do not apply excessive force to the height gage.</p> <ul style="list-style-type: none">• Do not drop or give sharp blows to the height gauge.	
3	<p>Be careful not to damage the scriber tip.</p>	
4	<p>Wipe off any dust from the height gage before use.</p> <ul style="list-style-type: none">• Thoroughly wipe the sliding surfaces, bottom face of the base and scriber measuring face.	
5	<p>Check the slider movement for smoothness. It should not feel loose or have any play. Correct any problems found by adjusting the pressing screw and setscrew. (as mentioned for vernier calipers)</p> <ul style="list-style-type: none">• Tighten the pressing screw and setscrew, then loosen them in a counterclockwise direction about 30°.• Check the sliding smoothness again.• Repeat the above procedure while adjusting the angular position of the screws until an appropriate sliding smoothness is obtained.	

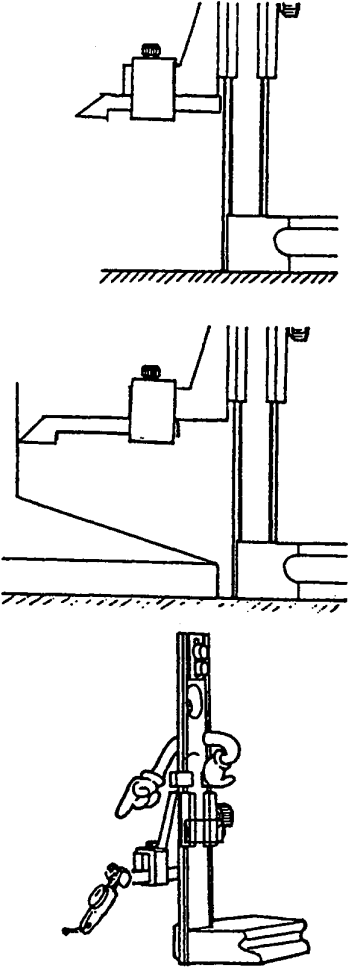
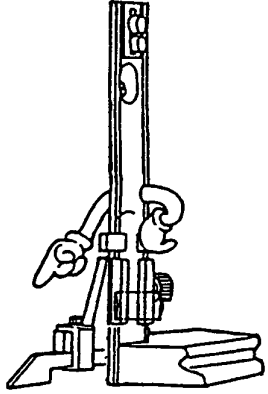
6	<p>Wipe off any dust from the surface plate and the workpiece and leave them (as well as the height gage) in the room long enough to adjust to room temperature.</p>	
7	<p>The distance from the beam reference surface to the scriber tip (or dial test indicator contact point) must be as short as possible.</p>	
8	<p>Adjust the zero line of the scale with reference to the surface plate.</p>	

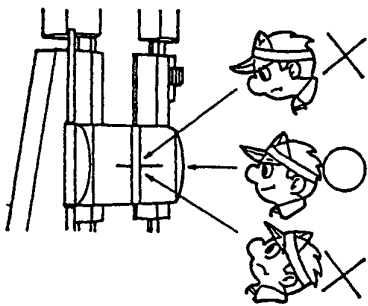
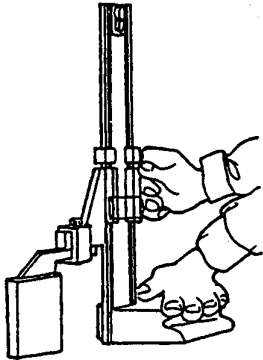
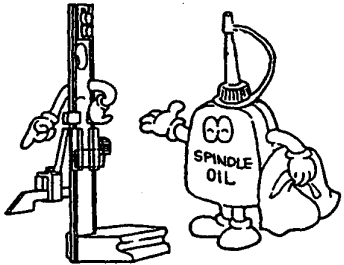
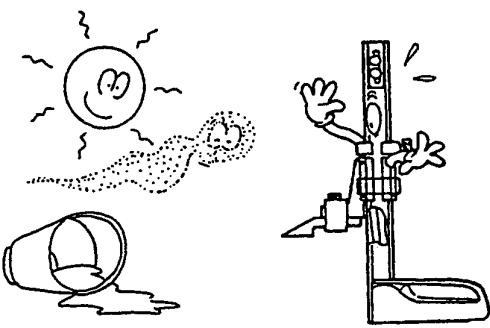
9	<p>Avoid parallax errors by reading the scale directly from the front.</p> <ul style="list-style-type: none"> • Position the lens where the lens center (thickest portion) is aligned to the matched graduation lines and eye level. 	
10	<p>During fine adjustment, be careful not to allow the base to lift up.</p>	
11	<p>After use, wipe dirt or finger prints from the height gage with a soft, dry cloth.</p>	
12	<p>When storing the height gage for long periods of time or when it needs oil, use a cloth dampened with rust preventive oil and lightly wipe each section (except for the carbide sections) of the height gage. Make sure that the oil is spread evenly over the surfaces.</p>	
13	<p>The following points should be kept in mind when storing height gages.</p> <ul style="list-style-type: none"> • Do not expose the height gage to direct sunlight. • Store the height gage in a low humidity and well ventilated environment. • Store the height gage in an dust free environment. • Do not place the height gage directly on the floor. • Do not clamp the slider. • Store the height gage with the scriber removed. If the scriber has to be kept mounted, position the scriber to a height of 2 - 20 mm (.08" to .8") from the base bottom. 	

DIAL INDICATORS

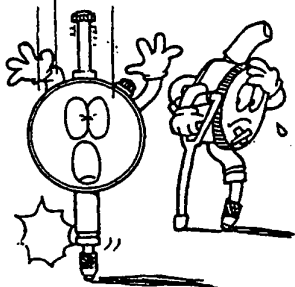
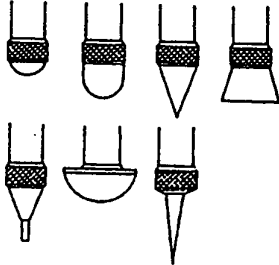
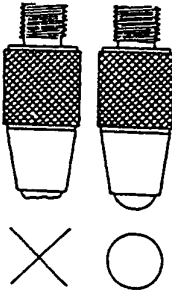
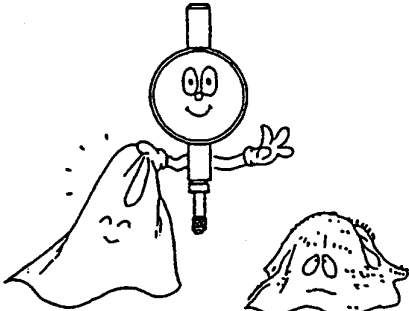
1	<p>Select the dial indicator that best fits the application.</p> <ul style="list-style-type: none"> • Make sure that the type, graduation, measuring range and other specifications of the dial indicator are appropriate for your application. 	
2	<p>Do not apply excessive force to the dial indicator.</p> <ul style="list-style-type: none"> • Do not drop or give sharp blows to the dial indicator. 	
3	<p>Use a contact point that best fits the application.</p>	
4	<p>Replace worn contact points.</p>	
5	<p>Wipe off any dust from the indicator before use.</p>	

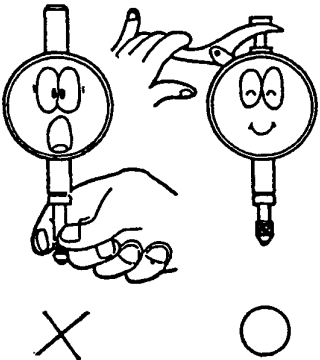
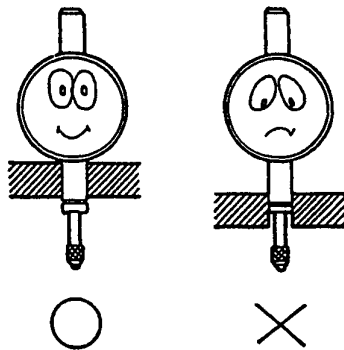
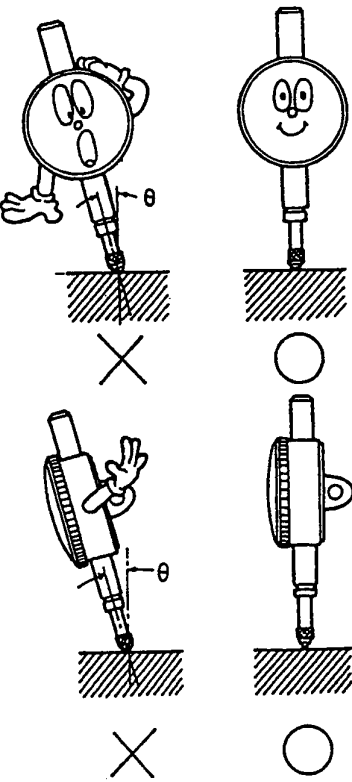
<p>6</p>	<p>Use the lifting lever to hold up the spindle.</p>																								
<p>7</p>	<p>When mounting the dial indicator on a stand or fixture, clamp the stem as close to the dial as possible.</p>																								
<p>8</p>	<p>When mounting the dial indicator on a stand or fixture, position it so that inclination angle θ is minimized.</p> <p>Example :</p> <table border="1" data-bbox="256 1228 824 1648"> <thead> <tr> <th rowspan="2"></th> <th colspan="3">Inclination angle θ</th> </tr> <tr> <th>0°</th> <th>10°</th> <th>30°</th> </tr> </thead> <tbody> <tr> <td>Indicator reading \times</td> <td>0.050mm (.002")</td> <td>0.050mm (.002")</td> <td>0.050mm (.002")</td> </tr> <tr> <td>Correction coefficient $\cos \theta$</td> <td>1.00</td> <td>0.98</td> <td>0.866</td> </tr> <tr> <td>Correction value $\times \cos \theta$</td> <td>0.050mm (.002")</td> <td>0.049mm (.00196")</td> <td>0.043mm (.0017")</td> </tr> <tr> <td>Error $\times (1 - \cos \theta)$</td> <td>0.000mm (0")</td> <td>0.001mm (.00004")</td> <td>0.007mm (.0003")</td> </tr> </tbody> </table>		Inclination angle θ			0°	10°	30°	Indicator reading \times	0.050mm (.002")	0.050mm (.002")	0.050mm (.002")	Correction coefficient $\cos \theta$	1.00	0.98	0.866	Correction value $\times \cos \theta$	0.050mm (.002")	0.049mm (.00196")	0.043mm (.0017")	Error $\times (1 - \cos \theta)$	0.000mm (0")	0.001mm (.00004")	0.007mm (.0003")	
	Inclination angle θ																								
	0°	10°	30°																						
Indicator reading \times	0.050mm (.002")	0.050mm (.002")	0.050mm (.002")																						
Correction coefficient $\cos \theta$	1.00	0.98	0.866																						
Correction value $\times \cos \theta$	0.050mm (.002")	0.049mm (.00196")	0.043mm (.0017")																						
Error $\times (1 - \cos \theta)$	0.000mm (0")	0.001mm (.00004")	0.007mm (.0003")																						

<p>9</p>	<p>Use a rigid stand for mounting the dial indicator and set up the indicator so that the center of gravity is above the base.</p> <ul style="list-style-type: none"> • Set up the dial indicator so that the distance from the column to the indicator is minimized. • Use a balance weight if necessary, so that the center of gravity is above the base. 	
<p>10</p>	<p>Avoid parallax errors by reading the dial directly from the front.</p> <ul style="list-style-type: none"> • Indicated value = reading of the short hand (revolution counter) + reading of the long hand 	
<p>11</p>	<p>After use, wipe dirt and finger prints from the dial indicator with a soft, dry cloth.</p>	
<p>12</p>	<p>When storing the dial indicator for long periods of time or when it needs oil, use a cloth dampened with rust preventive oil and lightly wipe the movement case and the stem. Make sure that the oil is spread evenly over the surfaces.</p> <ul style="list-style-type: none"> • Never oil the crystal, spindle or carbide tip of the contact point. 	
<p>13</p>	<p>The following points should be kept in mind when storing dial indicators.</p> <ul style="list-style-type: none"> • Do not expose the dial indicator to direct sunlight. • Store the dial indicator in a low humidity and well ventilated environment. • Store the dial indicator in a dust free environment. • Do not place the dial indicator directly on the floor. • Store the dial indicator in a case (or plastic bag). 	

DIAL TEST INDICATORS

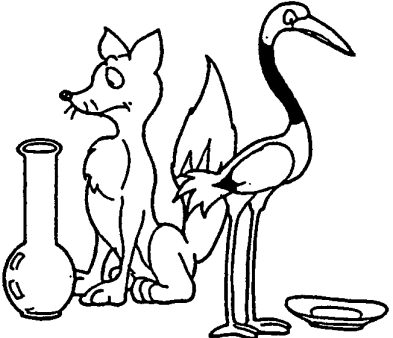
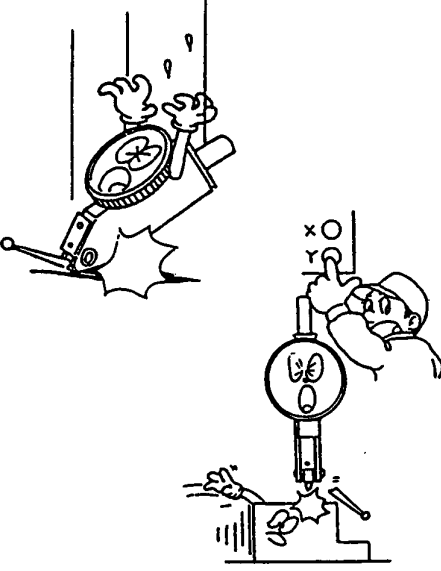
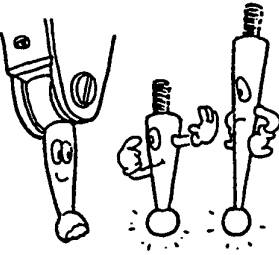
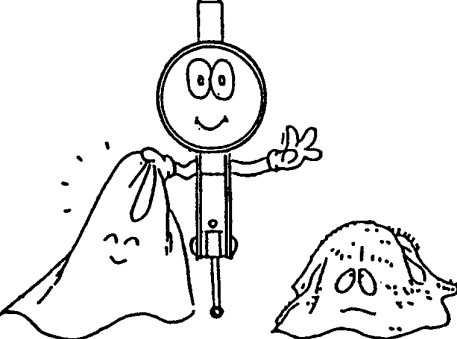
1	<p>Select the dial test indicator that best fits the application.</p> <ul style="list-style-type: none">• Make sure that the type, graduation, measuring range and other specifications of the dial test indicator are appropriate for your application.	 A cartoon illustration featuring a fox and a stork. The fox is sitting on the left, looking towards a round-bottom flask. The stork is on the right, holding a long-necked flask. There is also a small dish on the ground.
2	<p>Do not drop or give sharp blows to the test indicator .</p>	 A cartoon illustration showing two scenes. The top scene shows a hand dropping a dial indicator, with a jagged shape representing the impact. The bottom scene shows a person using a dial indicator on a workpiece, with a dial face showing a large 'X' and a small 'O'.
3	<p>Replace worn contact points only with those of the same size.</p>	 A cartoon illustration of three dial indicators. The first one has a large, rounded contact point. The second one has a smaller, more pointed contact point. The third one has a very sharp, thin contact point.
4	<p>Wipe off any dust from the dial test indicator before use.</p>	 A cartoon illustration of a dial indicator character with a face and arms. It is holding a cloth and wiping its dial face. To the right, there is a pile of dust or dirt.

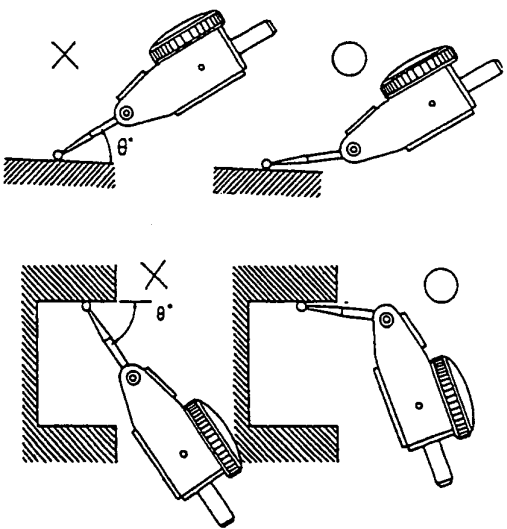
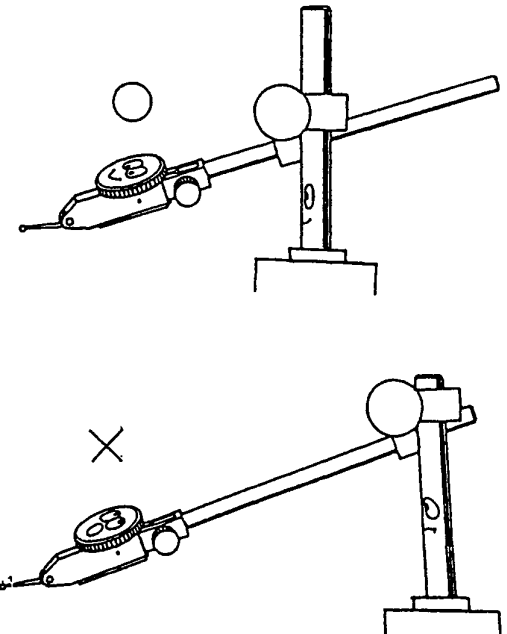
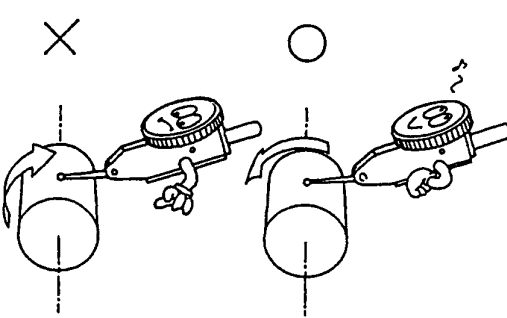
<p>5</p>	<p>When mounting the test indicator on a stand or fixture, position it so that inclination angle θ is minimized.</p> <p>Example :</p> <table border="1" data-bbox="267 346 844 766"> <thead> <tr> <th rowspan="2"></th> <th colspan="3">Inclination angle θ</th> </tr> <tr> <th>0°</th> <th>10°</th> <th>30°</th> </tr> </thead> <tbody> <tr> <td>Indicator reading x</td> <td>0.050mm (.002")</td> <td>0.050mm (.002")</td> <td>0.050mm (.002")</td> </tr> <tr> <td>Correction coefficient $\text{COS } \theta$</td> <td>1.000</td> <td>0.985</td> <td>0.866</td> </tr> <tr> <td>Correction value $x \text{ COS } \theta$</td> <td>0.050mm (.002")</td> <td>0.049mm (.00196")</td> <td>0.043mm (.0017")</td> </tr> <tr> <td>$x (1 - \text{COS } \theta)$</td> <td>0.000mm (0")</td> <td>0.001mm (.00004")</td> <td>0.007mm (.003")</td> </tr> </tbody> </table>		Inclination angle θ			0°	10°	30°	Indicator reading x	0.050mm (.002")	0.050mm (.002")	0.050mm (.002")	Correction coefficient $\text{COS } \theta$	1.000	0.985	0.866	Correction value $x \text{ COS } \theta$	0.050mm (.002")	0.049mm (.00196")	0.043mm (.0017")	$x (1 - \text{COS } \theta)$	0.000mm (0")	0.001mm (.00004")	0.007mm (.003")	
	Inclination angle θ																								
	0°	10°	30°																						
Indicator reading x	0.050mm (.002")	0.050mm (.002")	0.050mm (.002")																						
Correction coefficient $\text{COS } \theta$	1.000	0.985	0.866																						
Correction value $x \text{ COS } \theta$	0.050mm (.002")	0.049mm (.00196")	0.043mm (.0017")																						
$x (1 - \text{COS } \theta)$	0.000mm (0")	0.001mm (.00004")	0.007mm (.003")																						
<p>6</p>	<p>Use a rigid stand for mounting the dial test indicator and set up the indicator so that the center of gravity is above the base.</p> <ul style="list-style-type: none"> • Set up the dial test indicator so that the distance from the column to the indicator is minimized. • Use a balance weight if necessary, so that the center of gravity is above the base. 																								
<p>7</p>	<p>When measuring a rotating object, ensure that it rotates in the correct direction.</p> <ul style="list-style-type: none"> • Do not rotate the workpiece towards the contact point. 																								

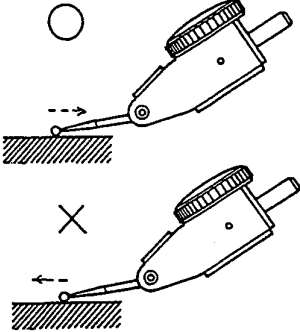
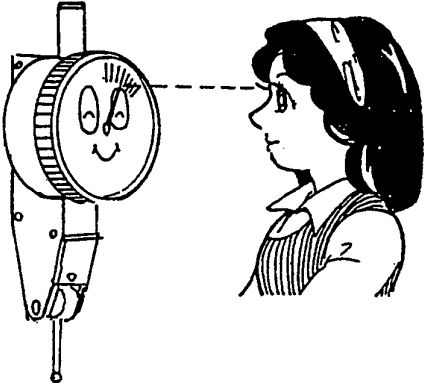
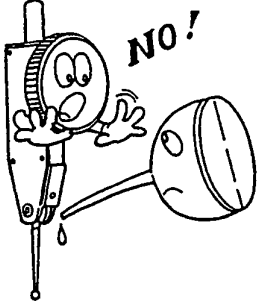
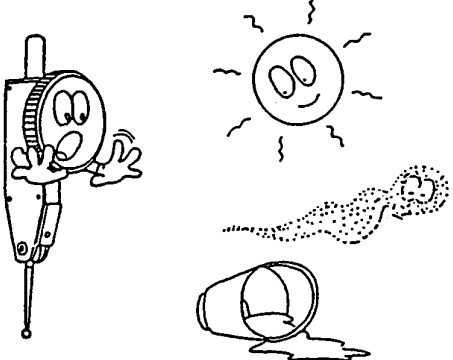
8	<p>When measuring a sliding object, measurement readings should be taken only when the workpiece is moving toward the contact point.</p>	
9	<p>Avoid parallax errors by reading the dial directly from the front. Note the relationship between the directions of the contact point displacement and indicator's hand rotation.</p> <ul style="list-style-type: none"> • Test indicators with no-clutch are available in two types; the continuous-reading type where the hand rotates clockwise regardless of the direction of contact point displacement from the hold position; the other being the balanced type where the direction of the hand's rotation changes according to the direction of the contact point displacement from the hold position. 	
10	<p>After use, wipe dirt and finger prints from the dial test indicator with a soft, dry cloth.</p>	
11	<p>When storing the test indicator for long periods of time or when it needs oil, use a cloth dampened with rust preventive oil and lightly wipe the frame, dovetail and stem. Make sure that the oil is spread evenly over the surfaces.</p> <ul style="list-style-type: none"> • Never oil the crystal or bearings. 	
12	<p>The following points should be kept in mind when storing dial test indicators.</p> <ul style="list-style-type: none"> • Do not expose the dial test indicator to direct sunlight. • Store the dial test indicator in a low humidity and well ventilated environment. • Store the dial test indicator in a dust free environment. • Do not place the dial test indicator directly on the floor. • Store the dial test indicator in a case(or plastic bag). 	

BORE GAGES

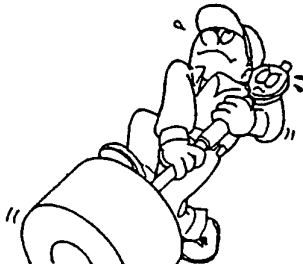
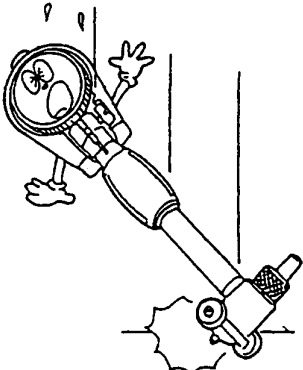
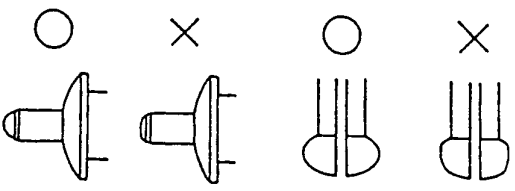
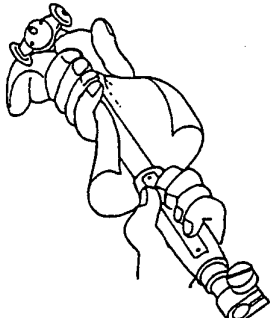
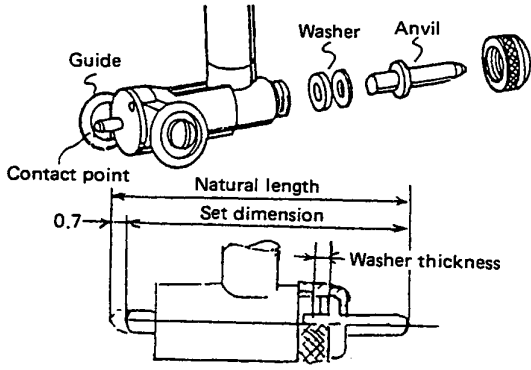
1	<p>Select the bore gage that best fits the application.</p> <ul style="list-style-type: none"> • Make sure that the type, measuring range, graduation, sleeve length, and other specifications of the bore gage are appropriate for your application. 	
2	<p>Do not drop or give sharp blows to the bore gage.</p>	
3	<p>Replace worn contact points and anvils.</p>	
4	<p>Wipe off any dust from the bore gage before use.</p>	
5	<p>Set the zero point (neutral point) of the bore gage, in 0.5 mm increments, to the approximate median of the bore diameter range.</p> <p>Example : Bore diameter range: 42.30 - 42.80 mm</p> <ul style="list-style-type: none"> • Measuring range : 35 - 60 mm • Dial indicator : 0.01 mm graduations • Zero point setting : 42.5 mm • Anvil's nominal size : 40 mm • Washer thickness : 2 mm + 0.5 mm 	

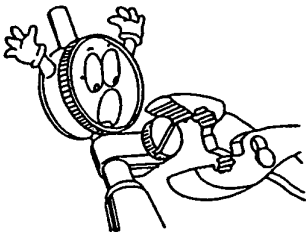
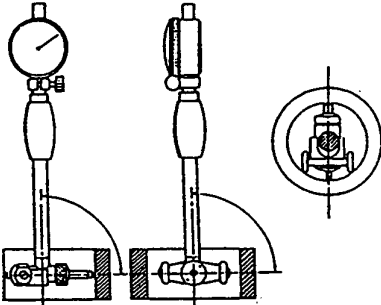
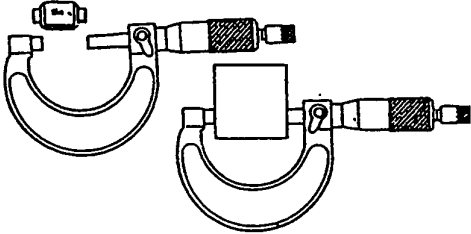
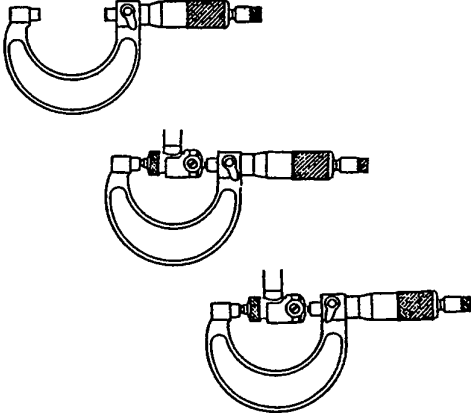
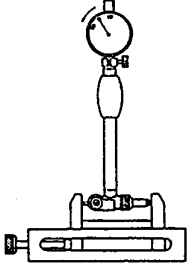
6	<p>Securely mount the indicator.</p> <ul style="list-style-type: none"> • Adjust the mounting depth while observing the position of the indicator hand. • Securely fasten the clamp (but do not over tighten). 	
7	<p>Zero set the indicator by using one of the following methods.</p> <p>A : Using a ring gage.</p>	
	<p>B : Using a micrometer and gauge block</p> <p>An object of a known dimension can also be used in place of gauge blocks if it is machined to a high level of parallelism and flatness.</p>	
	<p>C : Using a micrometer.</p> <ul style="list-style-type: none"> • Open the micrometer 0.1 to 0.2 mm (.004" to .008") wider than the required dimension. • With the bore gage held between the micrometer's measuring faces, adjust the micrometer and clamp it when the reading is equal to the required dimension. • Gently move the bore gage to the left end right while observing the movement of the hand. When the reading is at its minimum, move the dial indicator bezel so that the hand indicates the zero point. 	
	<p>D : Using a gauge block and fixing jig (gauge block accessories).</p>	

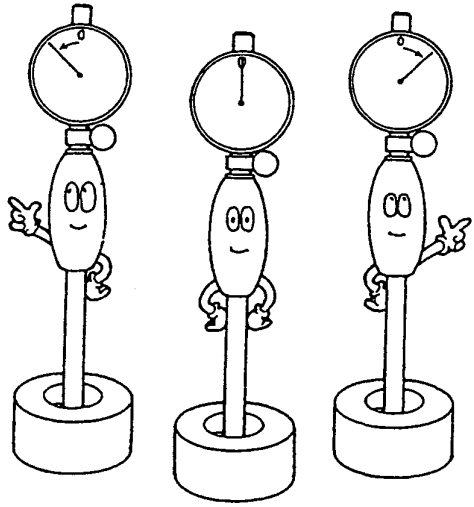
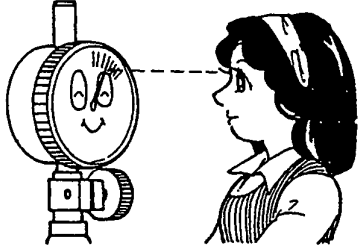
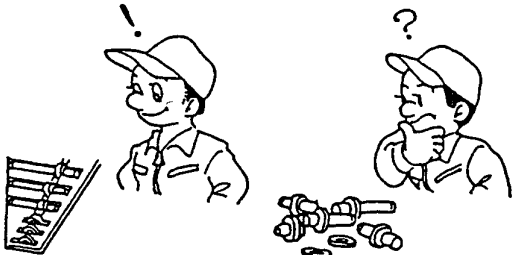
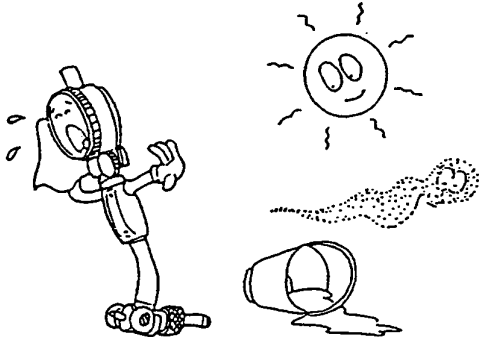
<p>8</p>	<p>Note the relationship between the directions of the contact point displacement and indicator's hand rotation.</p> <ul style="list-style-type: none"> • The clockwise rotation of the hand from the zero point indicates that the measured dimension is smaller than the set value. • The counter-clockwise rotation of the hand from the zero point indicates that the measured dimension is larger than the set value. 	 <p>Large diameter Reference Small diameter</p>
<p>9</p>	<p>Avoid parallax errors by reading the dial directly from the front.</p>	
<p>10</p>	<p>After use, wipe dirt and finger prints from the bore gage and the indicator with a soft, dry cloth.</p>	
<p>11</p>	<p>When storing the bore gage for long periods of time or when it needs oil, use a cloth dampened with rust preventive oil and lightly wipe each section of the gage. Make sure that the oil is spread evenly over the surfaces.</p> <ul style="list-style-type: none"> • Refer to step 13 on page 13 for the storage of the attached indicator. 	
<p>12</p>	<p>The following points should be kept in mind when storing bore gages.</p> <ul style="list-style-type: none"> • Do not expose the bore gage to direct sunlight. • Store the bore gage in a low humidity and well ventilated environment. • Store the bore gage in a dust free environment. • Do not place the bore gage directly on the floor. • Store the bore gage with the indicator removed. • Store the bore gage in a case. 	

Mitutoyo



Mitutoyo America Corporation – Corporate Office
965 Corporate Boulevard
Aurora, Illinois 60502
(630) 820-9666

Customer Service Call Center – (630) 978-5385 – Fax (630) 978-3501
Technical Support Call Center – (630) 820-9785

Mitutoyo Institute of Metrology
945 Corporate Blvd.
Aurora, IL 60502
(630) 723-3620
Fax (630) 978-6471
E-mail mim@mitutoyo.com

Visit www.mitutoyo.com