

Environment-Resistant Digital Gage LINEAR GAGE LG100 Series Compact-type Counter EJ Counter

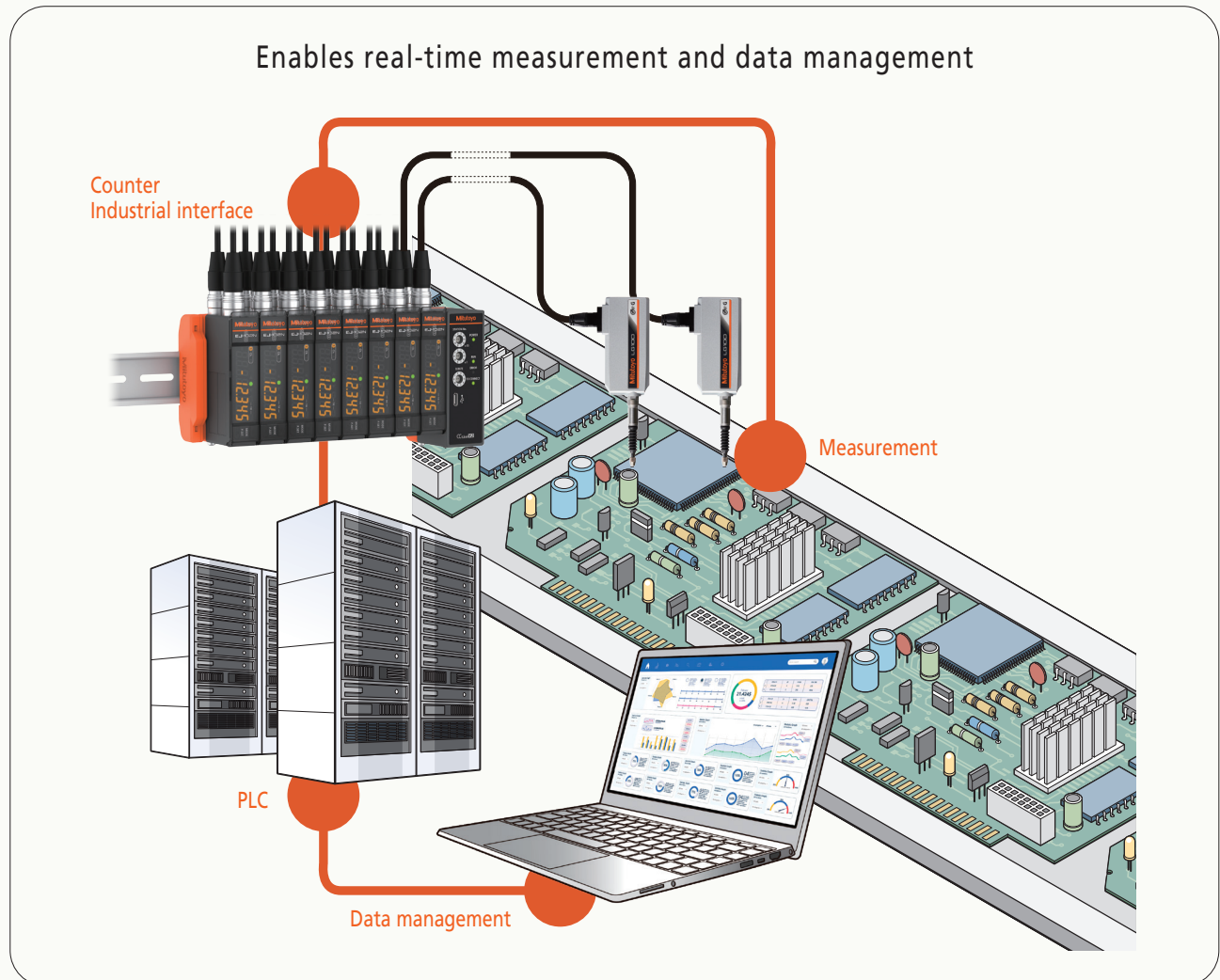

Can be used inline or in measurement cells

Best-in-class precision and environmental resistance.



Can be used in various production settings

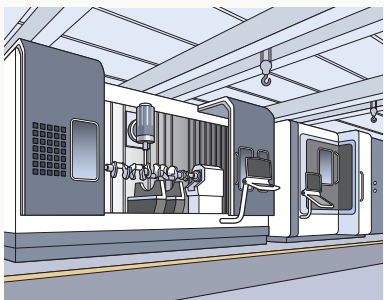

Processing

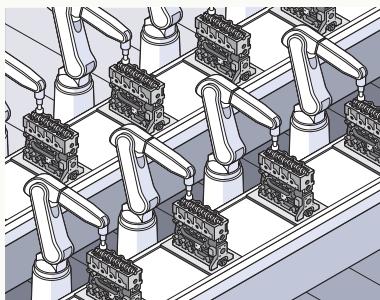

Assembly

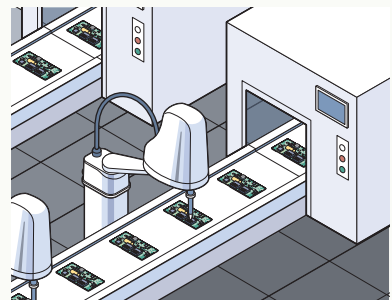

Inspection

Linear Gage LG100 Series



542-190/542-191/542-192
(10 mm stroke)



542-193/542-194/542-195
(25 mm stroke)



542-196/542-197
(50 mm stroke)



High accuracy

Precision and accuracy demanded by the automated assembly and inspection markets, are guaranteed. Due to our expertise as a manufacturer of measuring instruments, repeatability in the full measurement range (2σ) and narrow-range precision are also guaranteed.

Environment resistance

Sliding durability of more than 50 million cycles*, with protection level of IP67G. A highly oil-resistant material is used in the rubber cap and cable sheath, so it can be used even in harsh environments.

* 10 mm range models (Actual value from in-house tests)

Reference point detection

Reference point signal output functions are featured throughout this series. When incorporating into a device the master setting value is easy to set and is retained after shutdown. The ability to recall the origin ensures excellent reliability.

Combining compact size and ease of use

High-speed and compact, delivering production site visualization, improved productivity, and information feedback. Up to 8 compact counters (EJ counters) can be linked providing the capacity to connect up to 16 gages. On a DIN rail, each unit can be connected directly without using cables, so it takes up minimal space. All linked units and gages can be driven by a single power source.

Industrial interface-mounted compact counter EJ Series

Image of mounting



Counter unit
542-081A



Interface unit
CC-Link
USB



CC-Link connection, USB connection

Data can be output through an industrial interface (CC-Link) by linking a compact counter (EJ counter) with an interface unit. Constant data monitoring and positional management are performed. A USB interface is also provided for easy connection with a computer.

Note: The range of interfaces is set to be expanded in the near future.

Calculation function

Enables sum difference operations between 2 gages connected to the same counter. Functions such as tolerance judgment and peak hold are also included.

System Configuration

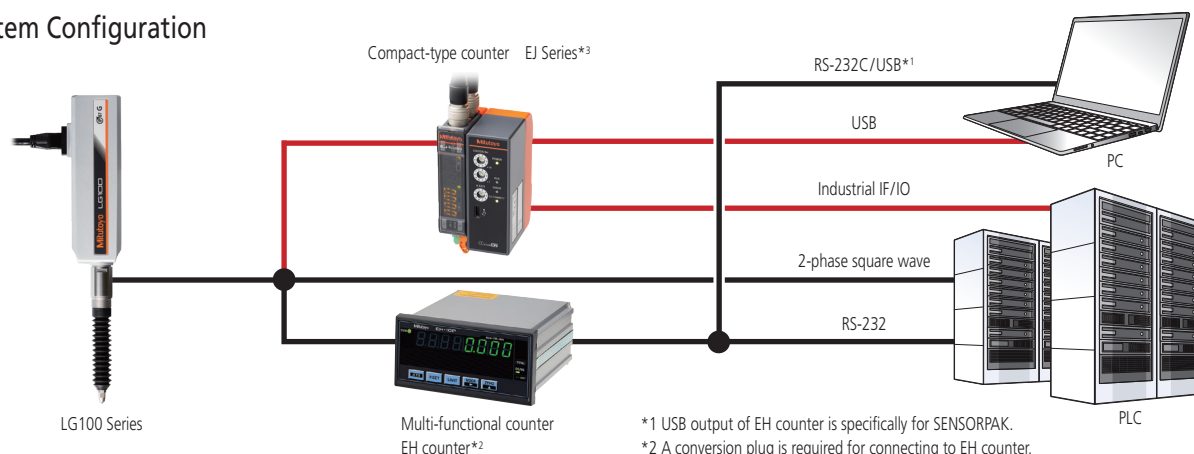

*1 USB output of EH counter is specifically for SENSORPAK.

*2 A conversion plug is required for connecting to EH counter.

*3 Conventional gages can be connected using conversion connectors.
(Please contact us for details of connectable gages.)

SOFTWARE

LG QuickSetupTool

A configuration tool is FREE for use with the EJ counter when connected via the optional USB interface. Multiple settings normally carried out with counter operating keys can now be easily applied from a computer.

Live displays allow for easily viewing gage positions or measurements at a glance.

Note: This software can be used free of charge and downloaded from the Mitutoyo website. <https://www.mitutoyo.co.jp/eng/contact/products/lg/>



Recommended system environment

OS: Windows10 Pro 32 bit/64 bit

Display: 1600×1200 or more

Memory: 1024 MB or more

Communication method: USB2.0 (Full speed)

USB connector: Type C connector

Note: USB device drivers are standard Windows drivers.

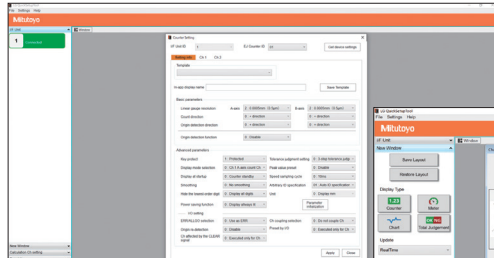

Parameter setting



Chart

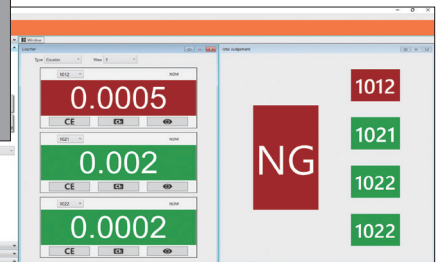

General settings

OPTIONS

Pneumatic lifter



For 10 mm range models: **02ADE230**

For 25 mm range models: **02ADE250**

For 50 mm range models: **02ADE270**

Rubber boot (spare)



For 10 mm range models: **21HAA331**

For 25 mm range models: **21HZA176**

For 50 mm range models: **21HZA184**

Thrust stem set / Spanner wrench

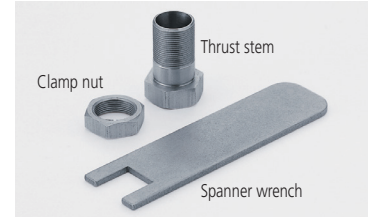

• Thrust stem set (Thrust stem, Clamp nut)

For 10 mm range models: **02ADB680**

For 25/50 mm range models: **02ADN370**

• Spanner wrench

For 10 mm range models: **02ADB683**

For 25/50 mm range models: **02ADB693**

Extension cable



Extension cable 5 m: **21HZA197**

Extension cable 10 m: **21HZA198**

Extension cable 20 m: **21HZA199**

Total length (gage to counter) must not exceed 20 m.

Conversion plug for connecting to EB/EG/EV Counter

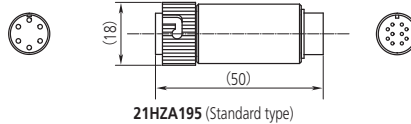

21HZA195 (Standard type)

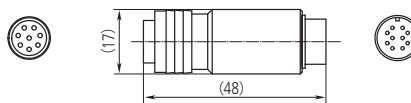

21HZA196 (With origin point mark)

Adapter shown installed on EH Counter

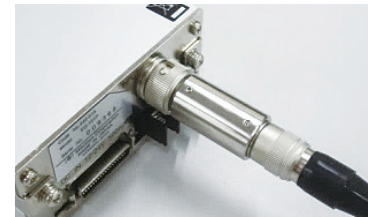

Standard type (for P counter): **21HZA195**

With origin point mark (for Z counter): **21HZA196**

For details of other options, please check the Linear Gage Brochure No. **E13007**.

APPLICATION

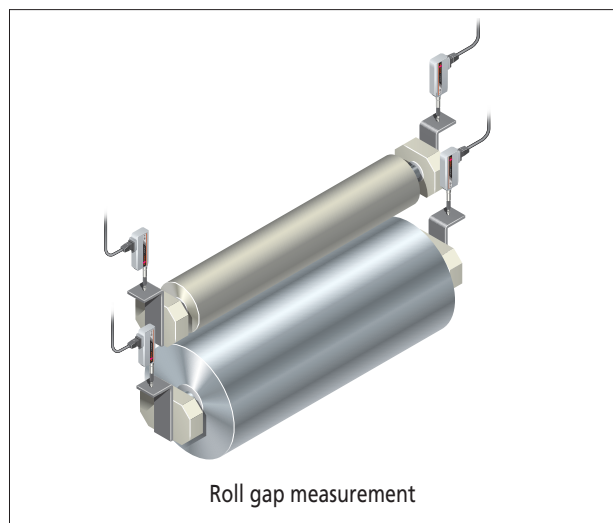
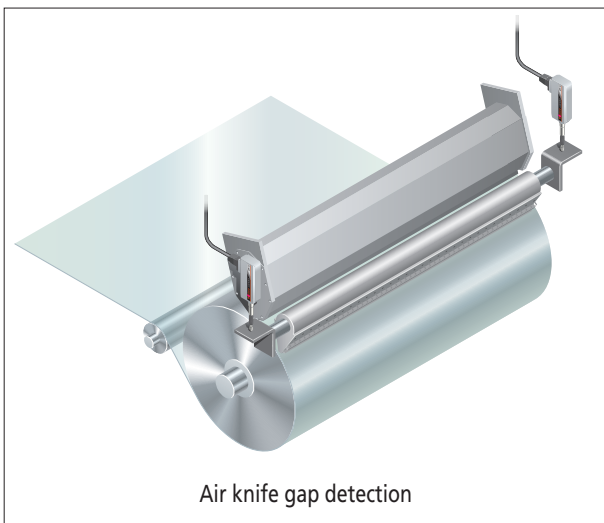
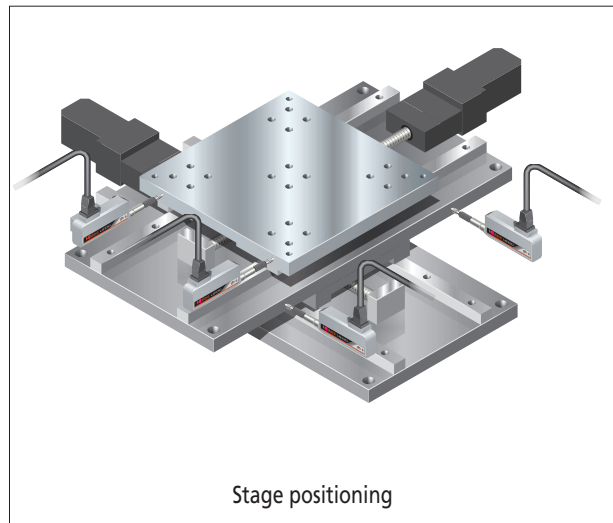
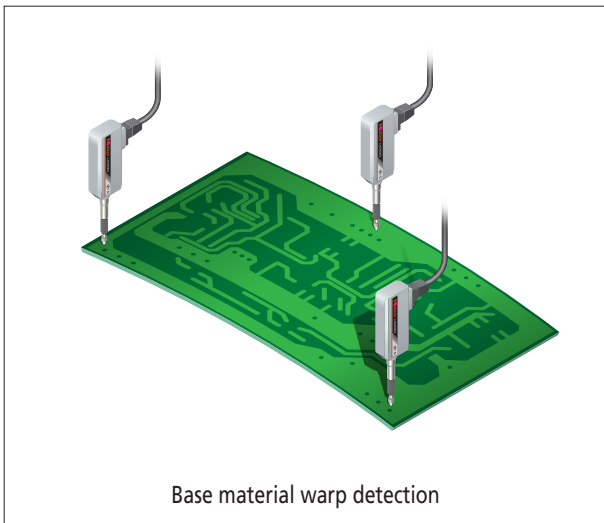
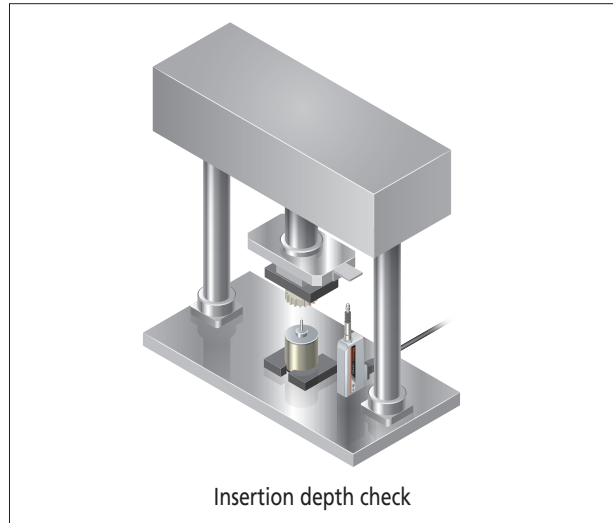
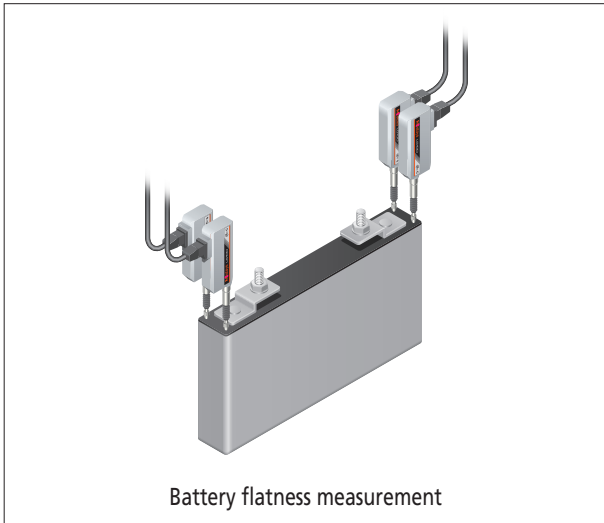

LG100 Series

SPECIFICATIONS

Order No.	542-190	542-191	542-192
Measuring range	.4" / 10mm		
Resolution	.000050" / 1µm .000020" / 0.5µm 5 uinch / 0.1µm		
Measuring accuracy (20 °C) L=arbitrary measuring length (mm)	1.5 + L/50 µm		0.8 + L/50 µm
Small range accuracy	0.5 µm (Arbitrary 20 µm range)		
Repeatability: 2σ (20 °C)	0.3 µm		
Reference mark repeatability: σ (20 °C)	σ ≈ 0.5 µm (at a constant reference point passing speed less than 300 mm/s in the same direction)		
Measuring force	Contact point downwards	1.4 N or less	
	Contact point horizontal	1.3 N or less	
	Contact point upwards	1.2 N or less	
Maximum response speed	1,500 mm/s		400 mm/s
Minimum edge intervals	500 ns (2 MHz)	250 ns (4 MHz)	
Output signal pitch	4 µm	2 µm	0.4 µm
Reference mark position (Phase-Z)	Approx. 3 mm from contact point tip (lowest rest point)		
Stem	ø8 mm		
Mass	Approx. 260 g		
Operating temperature (humidity) ranges	0 to 50 °C (RH 20 to 80%, non-condensing)		
Storage temperature (humidity) ranges	-10 to 60 °C (RH 20 to 80%, non-condensing)		
Standard accessories	Wrench for contact point: 538610		

SPECIFICATIONS

Order No.	542-196	542-197
Measuring range	50 mm	
Resolution	1 µm	0.5 µm
Measuring accuracy (20 °C) L=arbitrary measuring length (mm)	1.5 + L/50 µm	
Small range accuracy	0.5 µm (Arbitrary 20 µm range)	
Repeatability: 2σ (20 °C)	0.3 µm	
Reference mark repeatability: σ (20 °C)	σ ≈ 0.5 µm (at a constant reference point passing speed less than 300 mm/s in the same direction)	
Measuring force	Contact point downwards	5.7 N or less
	Contact point horizontal	5.3 N or less
	Contact point upwards	4.9 N or less
Maximum response speed	1,500 mm/s	
Minimum edge intervals	500 ns (2 MHz)	250 ns (4 MHz)
Output signal pitch	4 µm	2 µm
Reference mark position (Phase-Z)	Approx. 5 mm from contact point tip (lowest rest point)	
Stem	ø15 mm	
Mass	Approx. 400 g	
Operating temperature (humidity) ranges	0 to 50 °C (RH 20 to 80%, non-condensing)	
Storage temperature (humidity) ranges	-10 to 60 °C (RH 20 to 80%, non-condensing)	
Standard accessories	Wrench for contact point: 210187	

DIMENSIONS

• 542-190/542-191/542-192

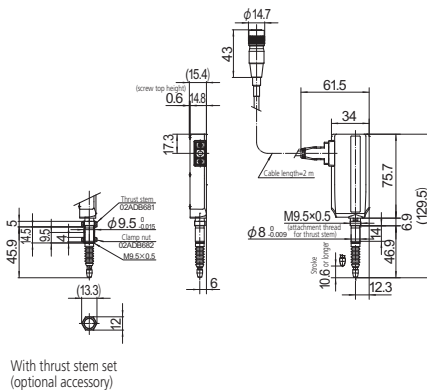

• 542-193/542-194/542-195

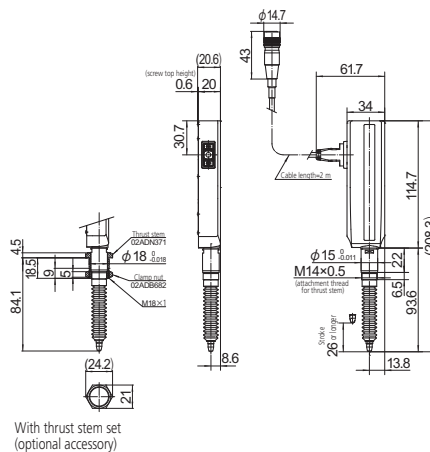

• 542-196/542-197

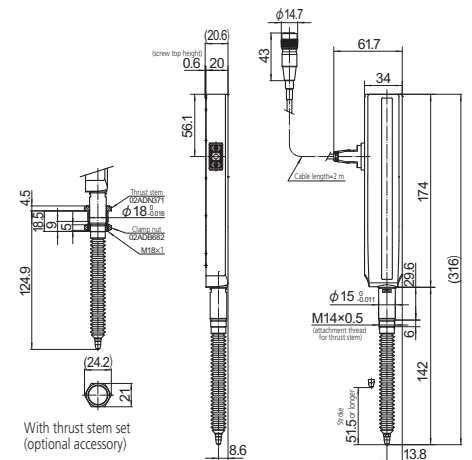

SPECIFICATIONS

Order No.	542-193	542-194	542-195
Measuring range	1" / 25mm		
Resolution	.000050" / 1µm .000020" / 0.5µm 5 uinch / 0.1µm		
Measuring accuracy (20 °C) L=arbitrary measuring length (mm)	1.5 + L/50 µm		0.8 + L/50 µm
Small range accuracy	0.5 µm (Arbitrary 20 µm range)		
Repeatability: 2σ (20 °C)	0.3 µm		
Reference mark repeatability: σ (20 °C)	σ ≈ 0.5 µm (at a constant reference point passing speed less than 300 mm/s in the same direction)		
Measuring force	Contact point downwards	4.6 N or less	
	Contact point horizontal	4.3 N or less	
	Contact point upwards	4.0 N or less	
Maximum response speed	1,500 mm/s		400 mm/s
Minimum edge intervals	500 ns (2 MHz)	250 ns (4 MHz)	
Output signal pitch	4 µm	2 µm	0.4 µm
Reference mark position (Phase-Z)	Approx. 5 mm from contact point tip (lowest rest point)		
Stem	ø15 mm		
Mass	Approx. 300 g		
Operating temperature (humidity) ranges	0 to 50 °C (RH 20 to 80%, non-condensing)		
Storage temperature (humidity) ranges	-10 to 60 °C (RH 20 to 80%, non-condensing)		
Standard accessories	Wrench for contact point: 210187		

Pin assignment

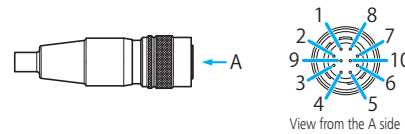

Pin No.	Signal	Pin No.	Signal
1	PA	7	N.C
2	P̄A	8	PZ
3	N.C	9	+5V
4	PB	10	GND
5	P̄B	Shell	FG
6	N.C		

- Power supply to a Linear gage
Power supply voltage: DC5 V (4.8 V to 5.2 V), Ripple voltage: 0.2 Vpp or less, Maximum current consumption: 80 mA
- Suitable receptacle and jack
Receptacle: HR10A-10R-10S (HIROSE)
Jack: HR10A-10J-10S (HIROSE)

EJ-102N/Interface unit CC-Link/Interface unit USB

SPECIFICATIONS

Order No.	542-081A	542-081
	Includes AC components	
Unit	inch/mm	
Resolution	0.0002, 0.00005, 0.00002, 0.000005 (inch)/ 0.005, 0.001, 0.0005, 0.0001 (mm)	
Number of linear gage connection ports	2	
Supported gage signal	Differential square wave, differential square wave with reference point mark	
Maximum input frequency	5 MHz	
User Interface	Display	Negative sign + 8 digits and indicator (1 gage value displayed, manually switchable)
External I/O	Number of I/O ports	Input: 4 ports (Ch switch, peak clear, data hold, preset) Output: 4 ports (Err/ALLGO, Tolerance judgment)
	Compatible communication standards	CC-Link, USB (Supported with optional interface units)
Max. number of linked units	EJ Counter 8 units + 1 (optional) interface unit (Max. number of linear gage connections: 16)	
Power supply	Input voltage	10 V to 27 V DC
	Power consumption	1 unit only: 3 W or less (Includes 2 linear gages) Max. number of links: 30 W or less (Interface unit and 16 linear gages included)
Operating temperature (humidity) ranges	0 to 50 °C (RH 20 to 80%, non-condensing)	
Storage temperature (humidity) ranges	-10 to 60 °C (RH 20 to 80%, non-condensing)	
Mass	Approx. 120 g	
CE Marking	EMC Directive: EN 61326-1 Immunity test requirement: Clause 6.2 Table 2 Emission limit: Class A RoHS Directive: EN IEC 63000	

Connectable linear gage series	Conversion cable (optional)
LG100	Not necessary
LGF-Z	Necessary (21HZA194)
LGF/LGK/LGB/LG	Necessary (21HZA193)

DIMENSIONS

• 542-081A/542-081

• Interface unit CC-Link

• Interface unit USB

Unit: mm

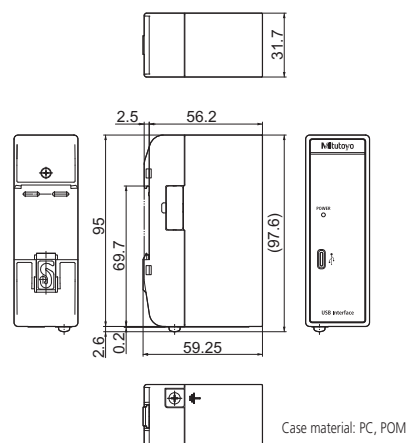
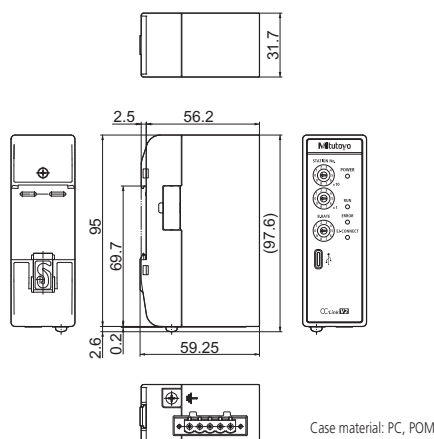
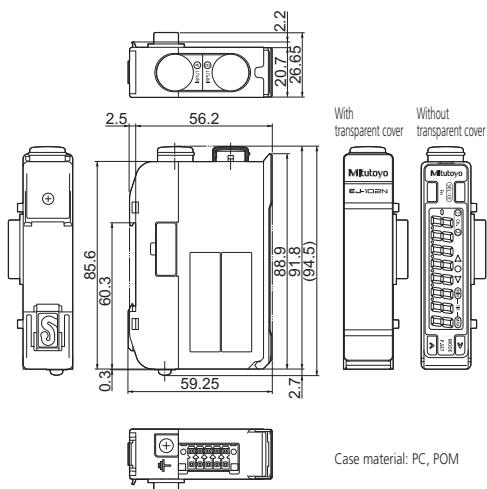

SPECIFICATIONS

Order No.	21HZA186
Model No.	Interface unit CC-Link
Applicable interface	USB 2.0 Full Speed
	CC-Link Ver. 1.10
	CC-Link Ver. 2.00
User Interface	Display
	Switch
Functions	POWER (green), RUN (green), ERROR (red), EJ-CONNECT (green) Rotary switch×3 (Exchange number settings×2, communication speed settings×1) Common protocols for USB and CC-Link, Readout of current value*1, Current value hold (software hold), Parameter setting on EJ counter, Tolerance judgment value settings, Preset value settings, preset/zero-set clear, peak clear, error clear *1 Only Ver. 2.00 is supported with CC-Link.
Power supply	Power is supplied from 542-081A/542-081 (Cannot be charged via USB)
Operating temperature (humidity) ranges	0 to 50 °C (RH 20 to 80%, non-condensing)
Storage temperature (humidity) ranges	-10 to 60 °C (RH 20 to 80%, non-condensing)
CE Marking	EMC Directive: EN 61326-1 Immunity test requirement: Clause 6.2 Table 2 Emission limit: Class A RoHS Directive: EN IEC 63000

SPECIFICATIONS

Order No.	21HZA149
Model No.	Interface unit USB
Applicable interface	USB 2.0 Full Speed
User Interface	POWER (green)
Functions	Readout of current value, Current value hold (software hold), Parameter setting on EJ counter, Tolerance judgment value settings, Preset value settings, preset/ zero-set clear, peak clear, error clear
Power supply	Power is supplied from 542-081A/542-081 (Cannot be charged via USB)
Operating temperature (humidity) ranges	0 to 50 °C (RH 20 to 80%, non-condensing)
Storage temperature (humidity) ranges	-10 to 60 °C (RH 20 to 80%, non-condensing)
CE Marking	EMC Directive: EN 61326-1 Immunity test requirement: Clause 6.2 Table 2 Emission limit: Class A RoHS Directive: EN IEC 63000

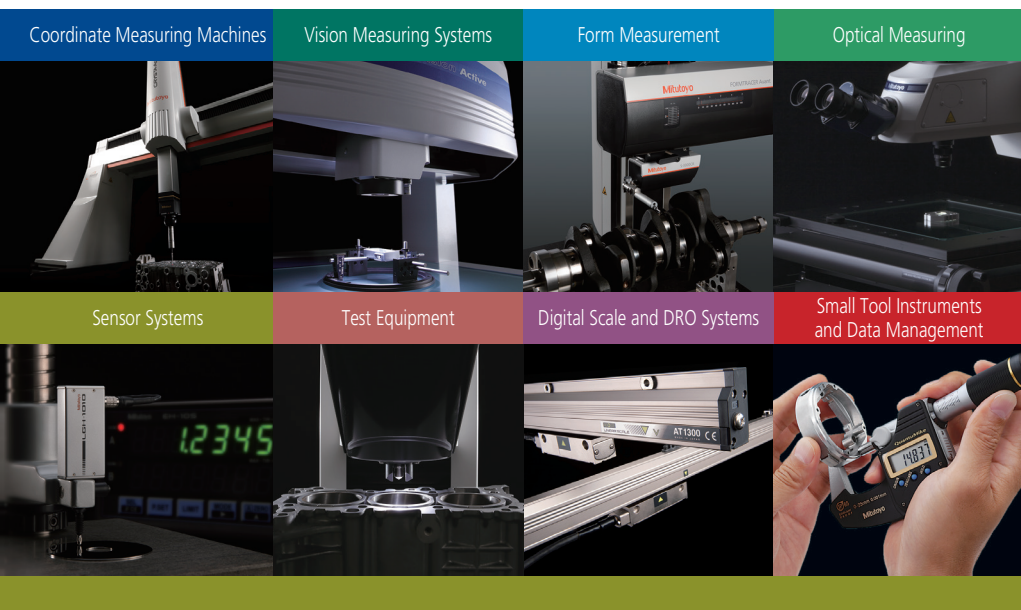

Whatever your challenges are, Mitutoyo supports you from start to finish.

Mitutoyo is not only a manufacturer of top quality measuring products but one that also offers qualified support for the lifetime of the equipment, backed by comprehensive services that ensure your staff can make the very best use of the investment.

Apart from the basics of calibration and repair, Mitutoyo offers product and metrology training, as well as IT support for the sophisticated software used in modern measuring technology. We can also design, build, test and deliver measuring solutions and even, if deemed cost-effective, take your critical measurement challenges in-house on a sub-contract basis.



Find additional product literature and our product catalog

www.mitutoyo.com

Note: All information regarding our products, and in particular the illustrations, drawings, dimensional and performance data contained in this printed matter as well as other technical data are to be regarded as approximate average values. We therefore reserve the right to make changes to the corresponding designs. The stated standards, similar technical regulations, descriptions and illustrations of the products were valid at the time of printing. In addition, the latest applicable version of our General Trading Conditions will apply. Only quotations submitted by ourselves may be regarded as definitive. Specifications are subject to change without notice.

Mitutoyo products are subject to US Export Administration Regulations (EAR). Re-export or relocation of our products may require prior approval by an appropriate governing authority.

Trademarks and Registrations

Designations used by companies to distinguish their products are often claimed as trademarks. In all instances where Mitutoyo America Corporation is aware of a claim, the product names appear in initial capital or all capital letters. The appropriate companies should be contacted for more complete trademark and registration information.



Mitutoyo America Corporation

www.mitutoyo.com
 One Number to Serve You Better
 1-888-MITUTOYO (1-888-648-8869)

M³ Solution Centers:

- Aurora, Illinois (Headquarters)
- Boston, Massachusetts
- Huntersville, North Carolina
- Mason, Ohio
- Plymouth, Michigan
- City of Industry, California
- Renton, Washington
- Houston, Texas