

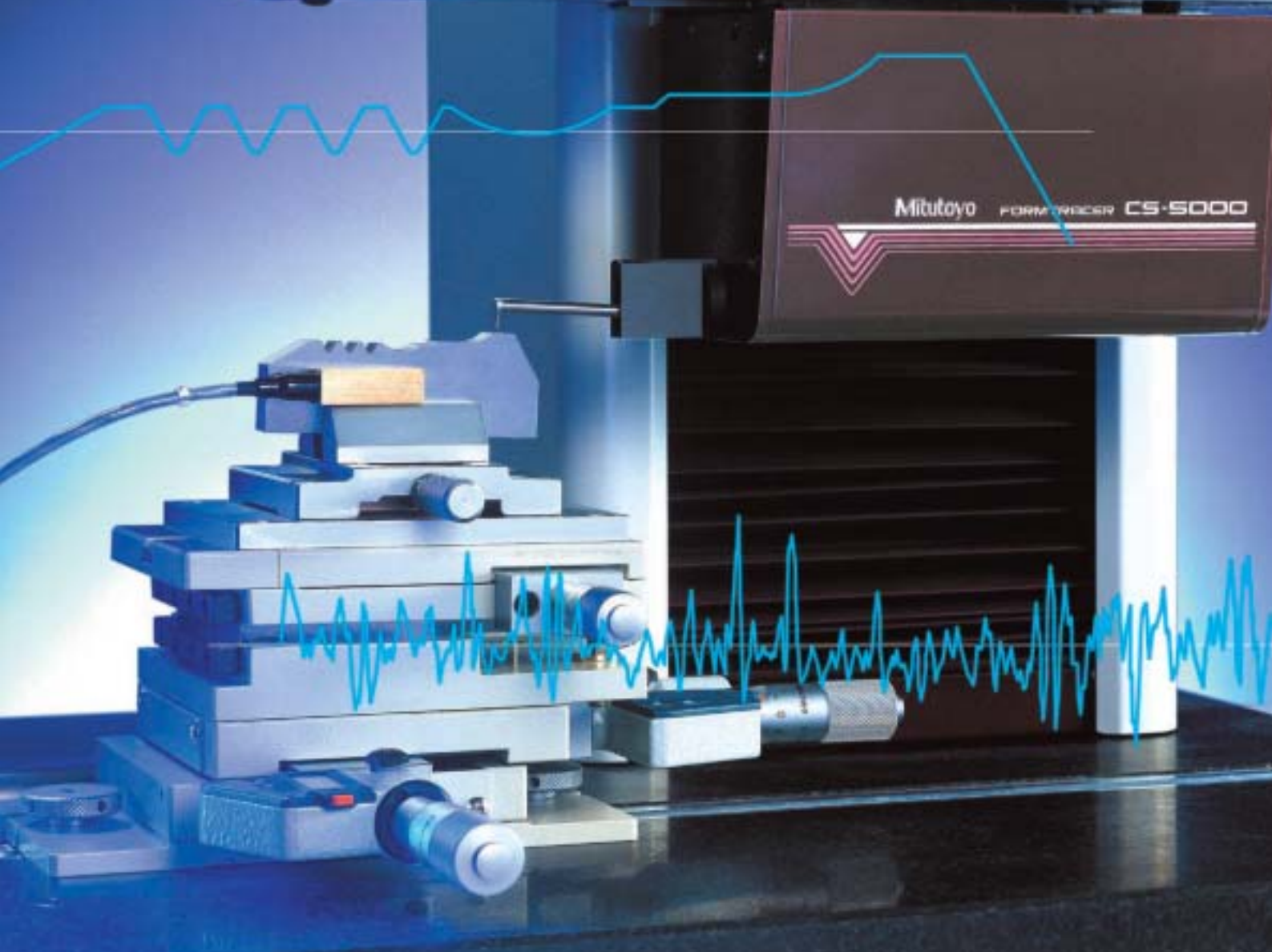

# FORMTRACER<sup>®</sup> CS-5000

## Hybrid Surface Contour Measuring Machine

Mitutoyo



Mitutoyo FORMTRACER CS-5000

# A hybrid surface contour measuring machine that combines "contour and surface roughness" measurements and analyses!

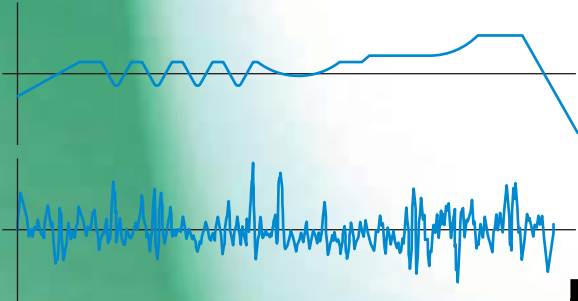

FORMTRACER

# CS-5000

**"Wide-range & high-resolution" detector!**

▪ Patent registered (Japan, U.S.A., England)  
▪ Patent pending (Japan, U.S.A., Germany, England)

**Employing Active Control Method, which reduces the variation of the dynamic measuring force to improve traceability and to thereby allow measurements with high-accuracy.**

**The X- and Z- axes are equipped with the Laser HoloScale, which boasts excellent narrow-range accuracy.**

## **Z-AXIS Newly Developed Detector**

- **Measuring range [resolution]**
  - **Standard stylus:**  
6mm (.024") [0.002 $\mu$ m (.08 $\mu$ inch)]
  - **Double-length stylus:**  
12mm (.47") [0.004 $\mu$ m (.16 $\mu$ inch)]
- **Measuring accuracy:**  
(0.3+|0.02H|) $\mu$ m [(12+|20H|) $\mu$ inch]

## **X-AXIS**

- **Measuring range [resolution]:**  
200mm(8") [0.00625 $\mu$ m (.25 $\mu$ inch)]
- **Measuring accuracy:**  
 $\pm$  (0.3+0.002L) $\mu$ m (12+2L) $\mu$ inch



# Measures and analyzes both "Contour" and "Surface roughness" altogether



S-5000



**"An analyzing program that integrates contour and surface roughness evaluations"**

▪Patent pending (Japan)

**"FORMPAK-1000" and "SURFPAK-SV", the popular contour analysis program and surface roughness analysis program are combined into FORMTRACEPAK!**

Measuring example

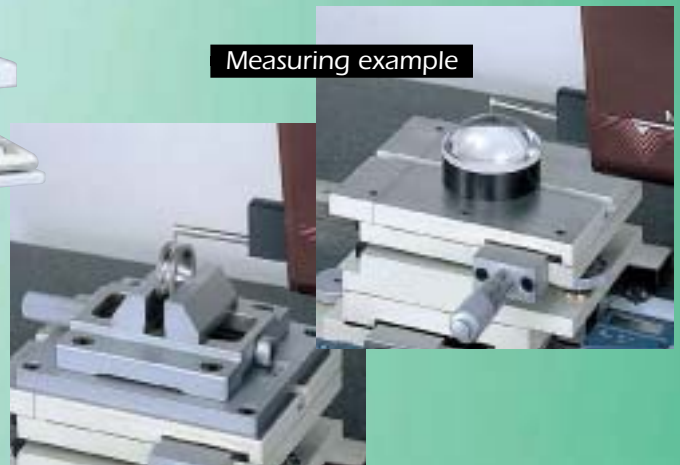

# Integration

Today in various industrial fields, where technologies are constantly advancing, even higher accuracy is required in measuring fine contours, as is seen in the machining industry and in fiber optics used in the information/communication equipment industries, to name a few. The CS-5000 series Formtracer is a high-accuracy, hybrid surface contour measuring machine that offers the world's highest level of accuracy and high-operability. It has been developed with the latest design engineering and production technologies of Mitutoyo, to answer the needs of these industries that employ the latest technologies.

# Evolution

## Body with high-rigidity

### Optimal design using the FEM analysis

In pursuit of a machine with a higher measuring accuracy, Mitutoyo combined the base, column, and the X-axis drive unit, and using a FEM structural-analytical simulation, the stress yielded in each member was thoroughly analyzed. Measurements with high-accuracy were thus made possible by the optimal structural design.

X-axis drive unit

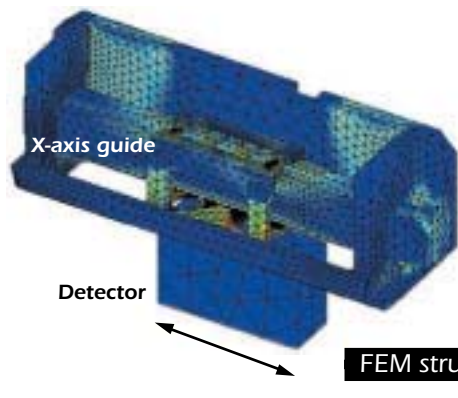

Entire machine structure

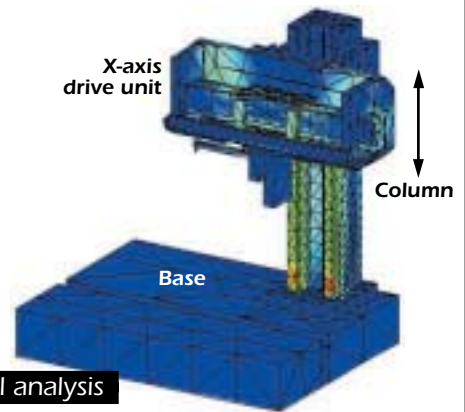

## Active control detection system

### The newly developed detector •Patent pending (Japan, U.S.A., Germany, England)

- Traces the workpiece surface while detecting the surface roughness, with high-accuracy.
- Offers high-traceability even on very steep inclined planes.
- Prevents variation of the measuring force in the entire measuring range of the Z-axis.

The resistance of the distortion gage changes when a displacement (vertical movement) of the stylus occurs, as shown in the figure on the right. The Voice coil controls the vertical movement of the stylus to keep the resistance of the distortion gage constant.

Structure outline of the CS-5000's Z-axis detector

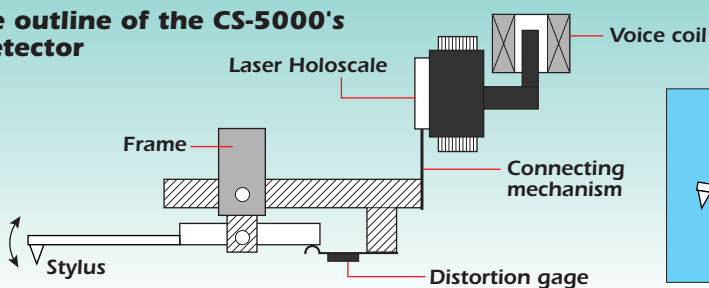

# High-resolution

## Equipped with Laser Hologscale •Patent pending (Japan, U.S.A., England)

The X-axis and Z-axis detectors are equipped with the Laser Hologscale, a scale that uses the interference of diffracted light, and boasts excellent accuracy in wide and narrow ranges. The Laser Hologscale offers the highest level of resolution in the world: X-axis  $0.00625\mu\text{m}$  (.25 $\mu\text{inch}$ ), Y-axis  $0.002\mu\text{m}$  (.079 $\mu\text{inch}$ ).

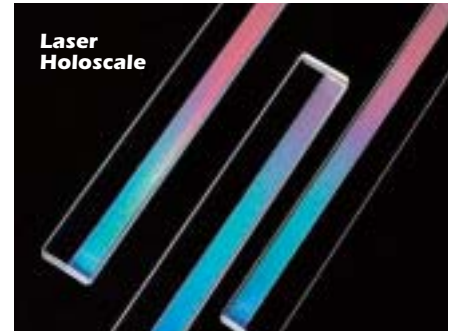
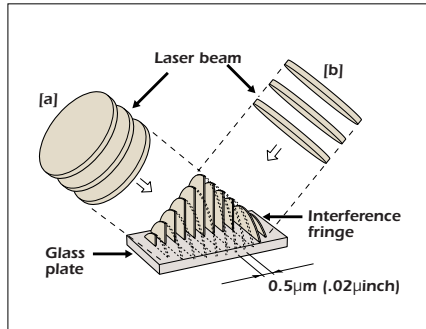
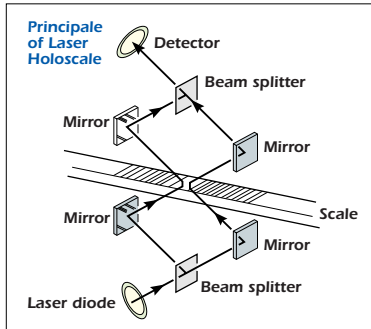

### What is the Laser Hologscale?

The Laser Hologscale uses intersecting laser beams [a] and [b] to create an interference fringe, which is recorded on the glass plate (scale). This means that the wavelength of the light is transferred directly onto the scale, allowing the scale pitches in order and the entire scale length to be exposed altogether. Thus, extremely high cumulative accuracy and linear accuracy with uniform pitches can be achieved at the same time, unlike with the Step & Repeat method, which produces uneven pitches, in the lithographic process using an original reduction exposure.

# X-axis guide with high-rigidity and high-accuracy

## Ceramic guide •Patent pending (Japan, Germany)

The X-axis employs a square pillar guide made of ceramics.

The slider is attached by a wire at the center of gravity of the frictional force generated by a sliding motion, to reduce the transmission of the vibration caused by the drive motor, thus minimizing hysteresis\* and thereby allowing high-accuracy traversing straightness of the drive unit. To accommodate this driving mechanism, the guide is shaped in a special form.

\*Hysteresis: a phenomenon in which the load and distortion that occur in a one-way travel do not match those of the return travel.

**Straightness**                      **Standard stylus :  $(0.05+0.0015L)\mu\text{m}$  [(2+1.5L) $\mu\text{inch}$ ]**  
**Measuring accuracy**           **Long stylus :  $(0.1+0.0015L)\mu\text{m}$  [(4+1.5L) $\mu\text{inch}$ ]**  
     **$(0.3+0.002L)\mu\text{m}$  [(12+2L) $\mu\text{inch}$ ]**

# Compensation technology

## Ultra-high accuracy •Patent pending (Japan, U.S.A., Germany, England)

### ▪ X-axis measuring accuracy compensation

The scale that is built-in in the column detects the height of the X-axis drive unit to compensate for a microscopic "distortion of the column", which occurs depending on the detector position on the X-axis.

(X-axis accuracy of  $(0.3+0.002L)\mu\text{m}$  [(12+2L) $\mu\text{inch}$ ] is guaranteed at any detector position on the (vertical) column.)

### ▪ Temperature compensation

Each of the X- and Z-axis scales is equipped with a built-in temperature sensor, which detects the ambient temperature as well as the workpiece temperature to allow temperature compensation.

(Allows contour measurements without the influence of workpiece and ambient temperatures.)

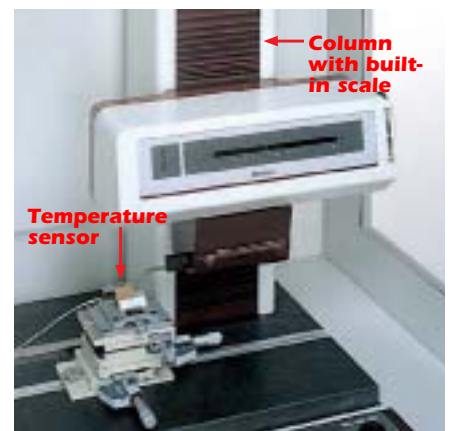



# CS-5000 - 3D

## High-accuracy three-dimensional topography

### Supports three-dimensional surface texture measurement and analysis

- CS-5000-3D provides a variety of graphics methods and evaluation parameters for various surface texture evaluations from the three-dimensional topography data.
- A desired topographic profile can be analyzed two-dimensionally, thus allowing the evaluation of fine contour and fine texture at the same time.



Y-axis table + three-dimensional auto-leveling table

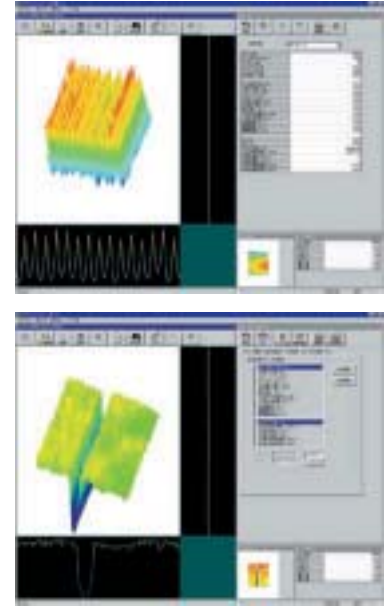

## Stylus

### Standard stylus

Length of stylus tip: 6.5mm (.26")  
 Tip material: diamond  
 Tip form: 40° cone  
 Radius of tip curvature: 5µm (.2µinch)

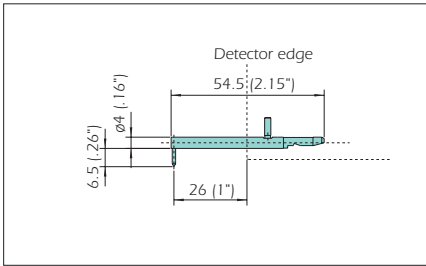

### Double-length stylus

Length of stylus tip: 12.5mm (.49")  
 Tip material: diamond  
 Tip form: 40° cone  
 Radius of tip curvature: 5µm (.2µinch)

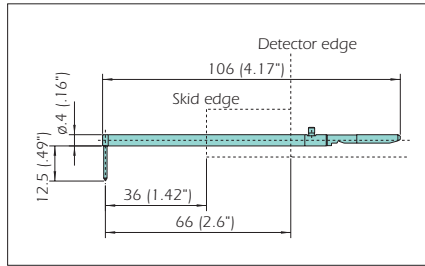

### Double-length ball stylus

Length of stylus tip: 12.5mm (.49")  
 Tip material: sapphire  
 Radius of curvature: 0.5mm ball

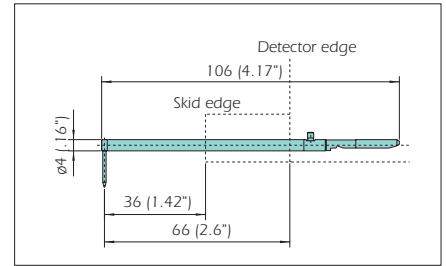

## Dimensions

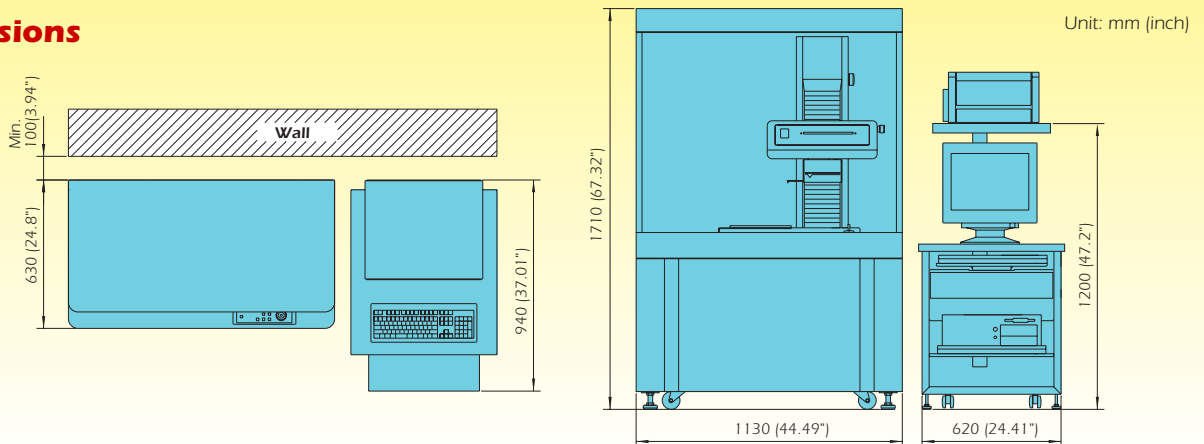

## SPECIFICATIONS

Model		CS-5000
Type		mm/inch
Order No.		<b>525-895A</b>
Measuring Range	X-axis	200mm (8")
	Z-axis	6mm (.24")/12mm (.47")*
	Column	250mm (10")
Resolution	X-axis	0.00625μm (.25μinch)
	Z-axis	0.002μm (.08μinch)/0.004μm (.016μinch)*
Accuracy (at 20°C)	X-axis	(0.3+0.002L)μm [(12+2L)μinch] L=traverse length
	Z-axis	±(0.3+ 0.02H )μm [±(12+ 20H )μinch] H=measuring height
Straightness	X-axis	(0.05+0.0015L)μm [(2+1.5L)μinch] (0.1+0.0015L)μm [(4+1.5L)μinch]* L=traverse length
	X- and Z-axis	Laser HoloScale
Measuring speed	Surface roughness	0.02mm/s(.0008"/s) to 0.2mm/s(.008"/s), can be specified by 4 steps
	Contour	0.02mm/s(.0008"/s) to 2mm/s(.08"/s), can be specified by 7 steps
Traverse speed	X-axis	0.1mm/s(.004"/s) to 1.5mm/s(0.06"/s), can be adjusted manually with a joystick box 0.1mm/s(.004"/s) to 3mm/s(.12"/s)*, can be adjusted manually with a joystick box
	Column	0.1mm/s(.004"/s) to 2mm/s(.08"/s), can be adjusted manually with a joystick box 0.1mm/s(.004"/s) to 4mm/s(.16"/s)*, can be adjusted manually with a joystick box
Digital data output		via GPIB interface
Stylus tip orientation		Downward
Feed direction		Both backward and forward
Measuring force		4mN(constant) : active control
Max.number of measuring points		125,000 points
Vertical travel distance of drive unit		250mm (10")
Power supply		AC120V
Power consumption		Max. 150VA (except for PC and printer)
Operation temperature		15 - 25°C
Dimension	Measuring unit	765x450x890mm (30.1"x17.7"x35")
	Control unit	250x380x300mm (9.8"x15"x11.8") **
	Vibration isolator	1130x630x760mm (44.5"x24.8"x30")
Mass	Measuring unit	140kg (308 lbs.)
	Control unit	7kg (15.4 lbs.) ***
	Vibration isolator	130kg (286 lbs.) **

\*When using a long stylus

\*\*Stored inside the vibration isolator

\*\*\*including the windshield cover

## Optional accessories



Cross travel table  
**218-041** (metric)  
**218-051** (inch)



Precision vise  
**178-019**



XY leveling table  
with swivel  
**178-052-1** (inch)  
(Standard accessory)



Rotary vise  
(two-slide jaw)  
**218-003**



Auto-leveling table  
**178-027**  
\*Patent registered (Japan)



Three-axis adjustment  
table  
**178-047**  
\*Patent pending (Japan)

Large size auto-leveling table: **178-028**  
Step reference specimen:

**178-611** (mm)/**178-612** (inch)

Roughness reference specimen:

**178-601** (mm)/**178-602** (inch)

Fixed table: **218-002**

Rotary table: **172-196**

Center support: **172-142**

Holder with clamp: **176-107**

Inclines center support: **172-197**

V-block

With cross-travel table: **172-234/172-378**

Two piece set: **181-902**

For cross-travel stage: **998291**

Riser: **172-143**

Windows is a registered trademark of Microsoft Corporation.  
Specifications are subject to change without notice.

DISTRIBUTED BY:

# Mitutoyo

## Mitutoyo America Corporation

NEW JERSEY

18 Essex Road,  
Paramus, NJ 07652  
Phone (201) 368-0525  
Fax No. 201-343-4969

MICHIGAN

45001 Five Mile Rd.,  
Plymouth, MI 48170  
Phone (734) 459-2810  
Fax No. 734-459-0455

ILLINOIS

965 Corporate Blvd.,  
Aurora, IL 60504  
Phone (630) 978-5385  
Fax No. 630-820-7403

CALIFORNIA

16925 Gale Ave.,  
City of Industry, CA 91745  
Phone (626) 961-9661  
Fax No. 626-333-8019

<http://www.mitutoyo.com>