

PH-A14 Profile Projector

Bulletin No. 1688

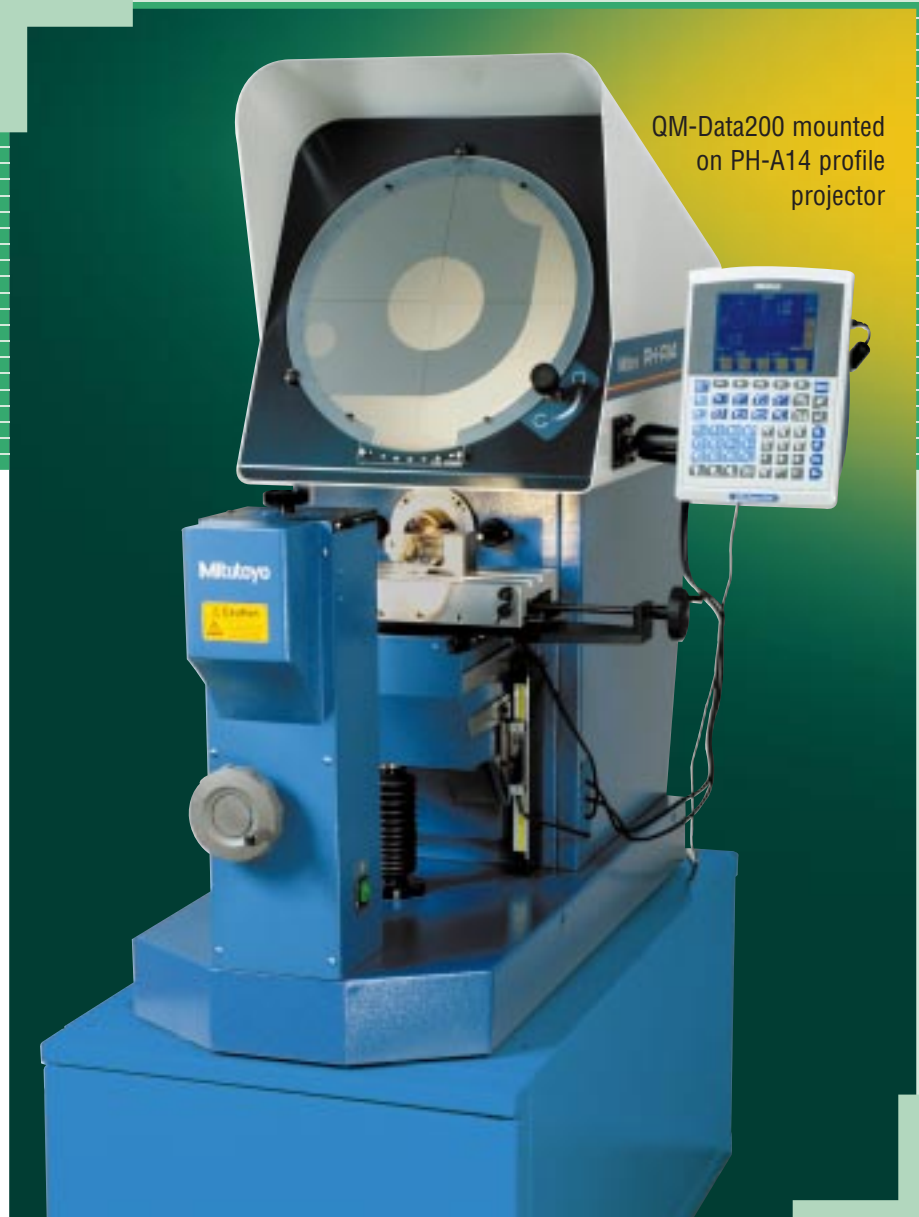

QM-Data200 mounted
on PH-A14 profile
projector

Horizontal Optical Comparator

Mitutoyo

PH-A14 Horizontal Optical Comparator

PH-A14 comes equipped with Linear Glass Scales factory mounted ready for your choice of optional display counters (shown with QM-Data 200)



Features:

- Mitutoyo's lens technology and workmanship combine to provide a bright, crisp image for error free inspection.
- The PH-A14's generous x, y workstage travel (8"x4") provides users with ample range to cover application needs.
- New location of the Y-axis handle improves ease of operation.
- The workstage provides high accuracy and can handle a workload of up to 100 lbs.
- Fiber illuminator is standard accessory.

Projection Lenses

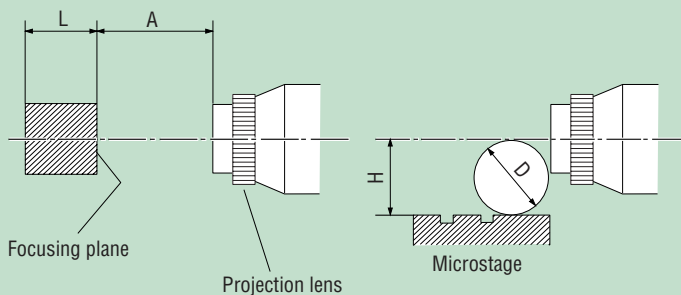

Unit: mm

Magnification	10X	20X	50X	100X
Mounting method	Screw mount			
Projection capacity				
Field of view	35.6	17.3	7.12	3.56
Working distance	A	93	40	14.6
Maximum workpiece width	L	235	235	80
Maximum projecting diameter	D	105	105	30.4
Maximum distance between the optical axis and microstage top face	H	105		

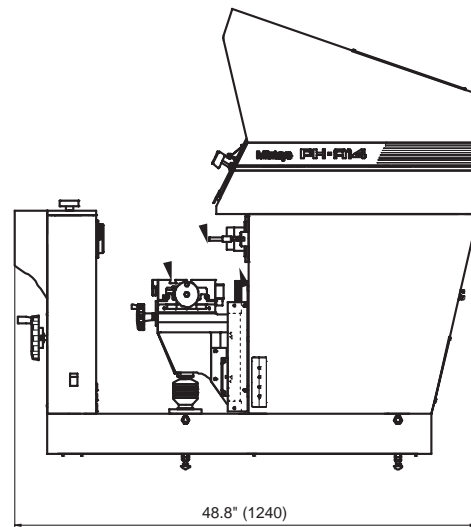
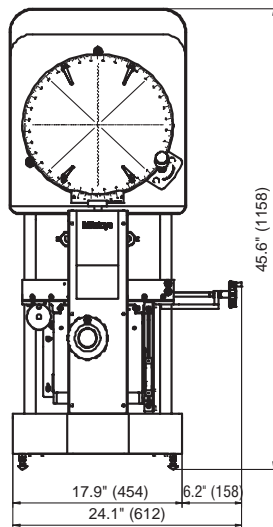

Specifications

Order No.	172-810A
Model No.	PH-A14
Projected image	Inverted image
Protractor screen	
Diameter	14" (356mm)
Material	Fine ground glass with cross - hair lines
Angle	Vernier reading, Resolution: 2'
Illumination	
Contour	24V, 150W (512305) halogen lamp, Telecentric illumination
Surface	24V, 150W (512305) halogen lamp, Twin fiber-optic illuminator
Magnifications	10X (Standard), 20X, 50X, 100X (Option)
Magnifications Accuracy	
Contour	0.1% or less
Surface	0.15% or less
Workstage	
(X-axis)	
Table travel	8" (203.2mm)
Table size	16" x 6" (407 x 153mm)
Reading unit	Linear Scale
Resolution	.00005" (0.001mm)*1
(Y-axis)	
Table travel	4" (101.6mm)
Reading unit	Linear Scale
Resolution	.00005" (0.001mm)*1
(Z-axis)	
Focusing travel	2" (50.8mm)
XY counter	Option
Power supply	120VAC, 50/60Hz
Dimension (W x D x H)	25.5" x 53.3" x 43.3" (648 x 1355 x 1100mm)
Weight	335lbs (152Kg)
Max Load	100lbs (45.37Kg)

*1 set by XY counter

Standard Accessories

Order No.	
172-011	Projection Lens 10x
512305	Halogen bulb 24V 150W (500 Hours)
358191	Fuse 6A (for 10-120V)
384208	Fuse 2.5A (for 220-240V)
538815	Hexagonal wrench 2.5
12BAC245	Spanner wrench 2.5 1
99MBA025A	Operational manual

See the backside for optional accessories

Optional Accessories

Order No.	Description
172-011	Projection Lens 10X (Standard)
172-012	Projection Lens 20X
172-013	Projection Lens Set 50X
172-014	Projection Lens Set 100X
172-116	Standard scale 50mm
172-117	Standard scale 2"
172-118	Reading scale 200mm
172-119	Reading scale 8"
172-161	Reading scale 300mm
172-162	Reading scale 12"
172-286	Green filter
172-142	Center support
172-143	Center support riser
172-132	Vertical holder
172-144	Rotary vise
172-234	V-block
64AAA129	Machine stand (W = 23" x D = 45" x H = 20") Weight: 129 lbs (58.53 Kg)
58AAA407	Counter tray
Data Processor and Display Counters	
264-141A	QM Data200 (Arm Mount Type)
983-357A	MicroPak 2RS
174-173A	KA Counter
Overlay Charts	
201305	Combination
201306	Grid / 15° Protractor
201307	Protractor
201308	Screw Thread
201491	Radius
201493	Radius / 10° Protractor

Center Support



172-142
Clamps a cylindrical workpiece such as a screw
Workpiece dia.: 120mm max

Rotary Vise



172-144
Workpiece dia.: 60mm max

V-Block with Clamp



172-234
Workpiece dia.: 50mm max

Center Support Riser



172-143
Widens the damping capacity of the center support to a maximum diameter of 240mm.

Vertical Holder



172-132
Set up a thin workpiece easily

Green Filter



172-286
Increases the screen sharpness of the contour image.

Optional Display Units



QM Data 200

QM-Data200

Order No.	264-141A (Arm-mount model)
Resolution	.00002"/.00005"/.0001" (0.0005mm/0.001mm)
Software	Standard geometric element Geometry combination pattern Memory: 1000 elements (max)
Dimension	7.87" (W) x 11.02" (H) x 3.54" (D)



KA Counter

KA Counter

Order No.	174-173A
Resolution	.0005"/.0002"/.0001"/.00005" (0.0005mm/0.002mm/0.001mm)
Dimension	10.2" (W) x 6.61" (H) x 3.2" (D)

*Need Counter Tray 64AAB003

Standard Scales



172-116 (50mm)
172-117 (2")

Used for checking magnifying accuracy.

Reading Scales

172-118 (200mm)
172-161 (300mm)
172-119 (8")
172-162 (12")



Designed for checking the magnified image of a standard scale.

Coordinate Measuring Machines

Vision Measuring Systems

Surface Roughness, Form and Contour Measurement

Digital Scale and DRO Systems

Optical Measuring Machines

Sensor Systems

Hardness Measuring Machines

Small Tool Instruments and Data Management

Mitutoyo America Corporation

www.mitutoyo.com

M³Solution Center

Michigan
(734) 459-2810

Illinois
(630) 978-5385

California
(626) 961-9661

Massachusetts
(978) 692-8765

Indiana
(317) 577-6070

No. Carolina
(704) 875-8332



JSAQ-052
ISO 9001

Mitutoyo

Precision is our Profession