

Quick Scope

CNC/Manually-operated
Vision Measuring
Microscope

Mitutoyo



Quick Scope Non-contact Vision Measuring
Microscopes Offer High Accuracy, Excellent
Affordability and Powerful Capabilities!

Non-contact Vision Measuring Microscope

Quick Scope

Series 359

Quick Scope has been developed through Mitutoyo's extensive experience and leading-edge technologies in optics and precision measuring. It performs complex, automatic measurements of batches of workpieces or prototype work with more measuring and analysis capability than a profile projector or traditional microscope.

- A color CCD camera provides real-life, sharp workpiece images.
- Available in CNC or manual version, with zoom or fixed magnification.
- Multiple lighting options allow users to customize their Quick Scopes to meet their particular lighting needs.

- Navigation and Graphic functions allow easy operation and movement around the part.
- One-click edge detection.
- Macro icon tools for many common measuring routines.
- Compact and light weight design fits where you need it.
- Powerful, Windows® based software is easy-to-use and intuitive.

Windows is a registered trademark of Microsoft Corporation.

Easy-to-use
Manually-operated System

QS-E



Features/benefits

- Excellent surface observation model for a wide variety of workpieces.
- 0.1 μ m resolution and 150mm (6") Z-axis range.
- Power zoom allows for easy and fast magnification change.
(QS-E1020 is a fixed-magnification type)
- Fine illumination capability allows for lighting changes to match workpiece requirements.
- The quick release system in the stage allows instant switching between a coarse movement and a fine movement.
- Quick Navigation function allows the user to do repeat measurements quickly.

Features

Excellent Performance-cost Ratio CNC System

QS



Estimated times to measure common workpieces with Quick Scope compared to a traditional microscope:

| Workpiece | QS (CNC) | Microscope |
|------------|-----------|------------|
| Lead frame | 9 minutes | 60 minutes |
| P.C.B. | 6 minutes | 60 minutes |

Features/benefits

- Surface, contour and fiber-optic ring light illumination options allow users to configure the QS lighting to meet a variety of measurement needs.
- Powerful, Windows® based QSPAK software is easy to use and offers a wide range of measuring and analysis capabilities.
- Functions include zoom, auto-focus, measurement playback, one-click edge detection, graphic display, 48 different macros, and a pattern matching function for several common part features.
- X,Y stage can be controlled by mouse or through the optional multi-function control box.

| Model | QS | QS-E |
|--------------------------------------|----|------|
| CNC | ○ | |
| Auto-focus | ○ | |
| Ring light illumination | ○ | ▲ |
| Zoom lens | ○ | |
| Control box | ▲ | |
| Programmable illumination adjustment | ○ | |
| QSPAK | ○ | ○ |

○: Provided, ▲: Available as option, : Not available

Most Affordable Manually-operated System

QS-E

Features/benefits

- The most affordable Quick Scope model.
- 0.1µm resolution and 6" (150mm) Z-axis range.
- Magnification can be adjusted by changing objectives.
- Excellent observation/measurement for single workpieces.
- The quick release system on the stage allows instant switching between coarse movement and fine movement.
- An optional fiber-optic ring light is available.
- Graphic and Navigation functions allow for quick maneuvering around the workpiece.
- Part programs are easily created in the Windows® based QSPAK software.



Space Saving and Compact Design!

QS SERIES

QS250Z

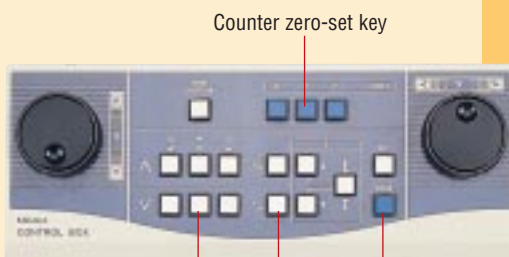

Counter zero-set key

Illumination control key

Data entry key

Zoom lens magnification control key

Easy operation with multi-function control box (optional accessory)

True color image processing function

A color CCD camera is used to provide realistic workpiece observation and measurement. The color image can be captured and stored as a bitmap image for other uses and can be printed out.

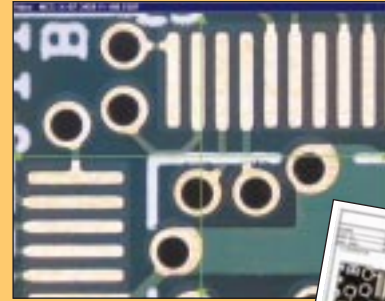

Print sample of video printer

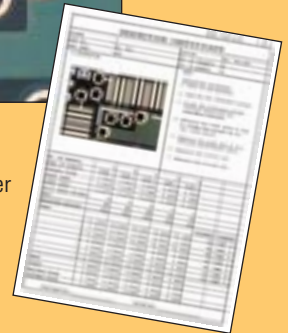

Built-in control unit for QS

The illumination intensity and zoom lens control unit is built-in to the housing for protection.



Fiber-optic ring light illumination

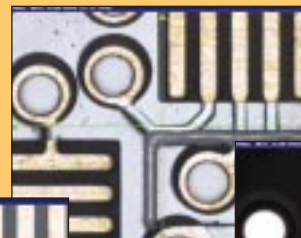

Surface (coaxial) illumination

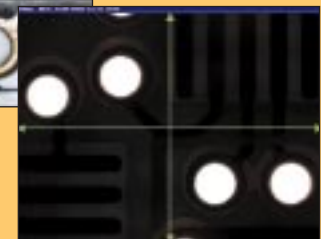

Contour (stage) illumination

Fiber-optic ring light provides sharp, clear images of your workpiece (QS and QS-L models)

In addition to surface and contour illumination, the QS and QS-L models of Quick Scope are equipped with a fiber-optic ring light as standard equipment, providing clear color images without shadows.

QSPAK

A unique vision measuring software system that provides powerful measuring capabilities and comprehensive measurement analysis



- QSPAK operates in a Windows® based operating system for easy operation with on-screen dialog.
- All operations can be performed on-screen for maximum operator efficiency: measuring, workstage drive, zoom control, illumination, data processing, and printing.
- Macros include one-click edge detection for fast distance and angle calculation, and circle measurement—just by clicking on the icon and then the feature on the screen.

- Easy X,Y table navigation function provides on-screen instructions for automatic measurement or repeat measurements.
- Template matching and manual pattern matching functions allow for comparison to many common part forms.
- Bit-map image storage capability.

For observation/comparison of a form

- Template matching function
- Manual pattern matching function

For simple measurement

- One-click edge detection tool function
- Smart tool function
- User macro function

For repeated measurement/ auto-measurement

- Stage navigation function (QS)
- Quick navigation function (QS-E)
- Playback function
- Graphic function
- External data output function
- Statistical calculation function

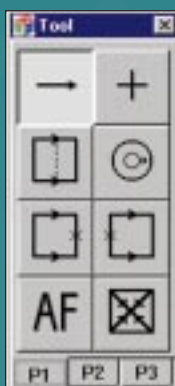

One click edge detection

By clicking the mouse near the edge of a workpiece, QSPak automatically scans the edge and detects it, showing its coordinates. This function also works with the point tool, box tool, circle tool and auto-focus tool.

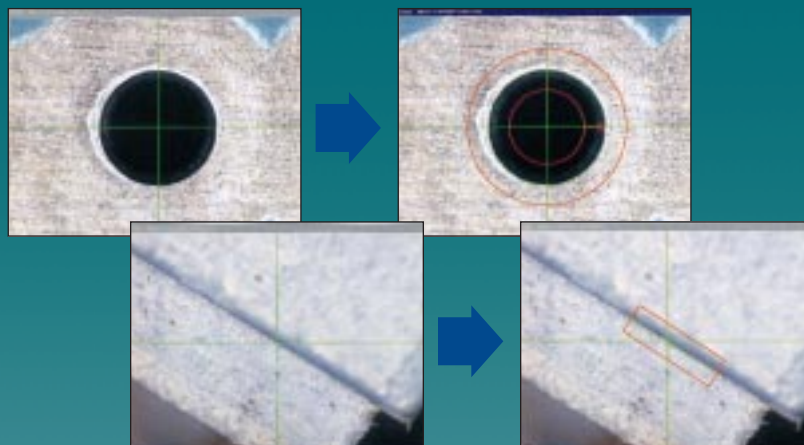

Macro functions

The function window allows easy selection of macro icons for 48 different measurements. Macros are shown on three different pages, easily accessed by tabs located along the bottom edge of the window. Using the macro function, QSPAK automatically selects the appropriate measuring tool to detect workpiece edge and calculate the appropriate feature: diameter, radius, etc.

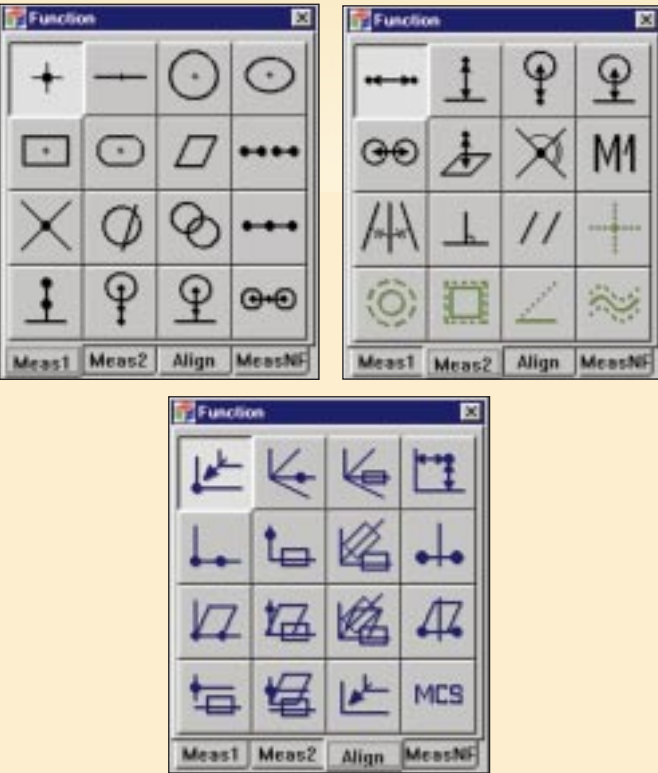

Smart Tool

By moving an image into the central measuring circle, QSPAK automatically scans and detects the clearest edge and centers it in the circle. It's faster and more accurate than using a profile projector or a microscope with cross-hairs.

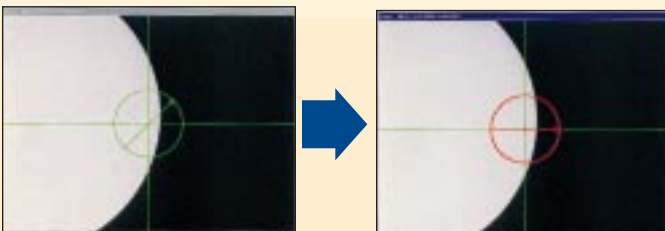

Template Tools

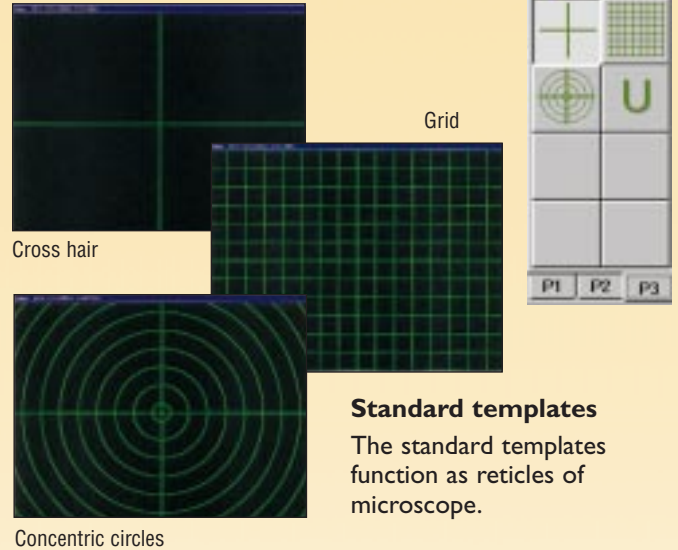

Standard templates
The standard templates function as reticles of microscope.

Manual pattern matching

Different templates can be generated from the master workpiece which are not included in the standard and extended template sections. Upper and lower tolerance levels can be added onto the master workpiece template by entering the tolerance values via the keyboard. This allows the user to customize templates for individual workpieces.

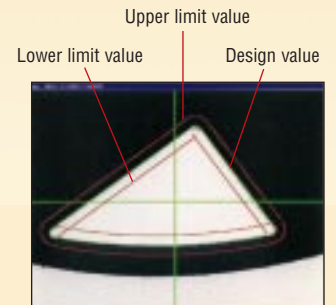

Upper and lower tolerance limits can be added

Input the edges by using the manual tool. Join the input points to complete the template.

Extended templates

Four other templates are available as extended template: cross, circle, square and angle. The size of a diameter, a distance, an angle, etc. can be changed just by entering a desired value with the keyboard. It allows simple comparison measurements, only much faster and more accurately than with a profile projector.



Cross

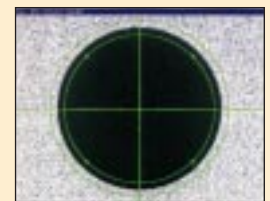

Circle



Square



Angle

Stage navigation function (QS CNC model)

The stage navigation function allows X,Y stage movement with the mouse. It speeds measurement and shortens part programming time by reducing stage overrun and short run. For long travel, the user can click on the drawing image in the graphic window; short travel is accomplished by clicking on the video window.

Step feeding is also possible on the QS model. By setting a desired value and clicking an arrow (up, down, right, left) the stage will move according to the entered value. In addition to the machine coordinate system, the stage can be moved using the workpiece coordinate system. The user can measure the workpiece without worrying about its positioning on the table.

Stage control through graphic window

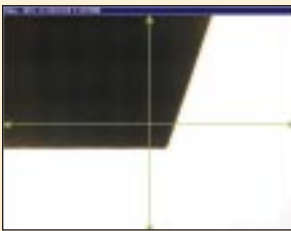

Click the mouse with "Ctrl" key, Quick Scope moves to the position clicked.

Stage control through video window

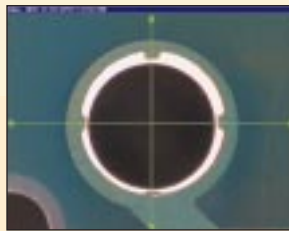

Click the mouse with "Ctrl" key, the clicked point will be centered on the display.

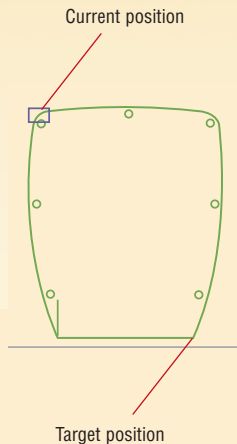

Stage movement in the workpiece coordinate system

In addition to the machine coordinate system, when moving the stage by step feeding, the workpiece coordinate system is available. The stage can be moved along the workpiece coordinate system set.

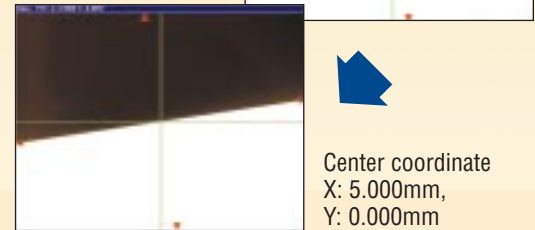
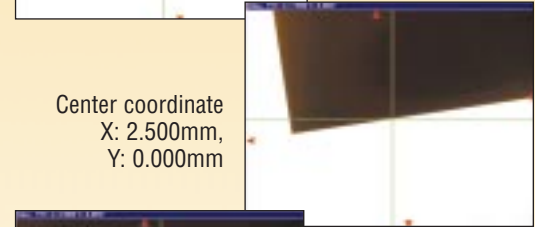
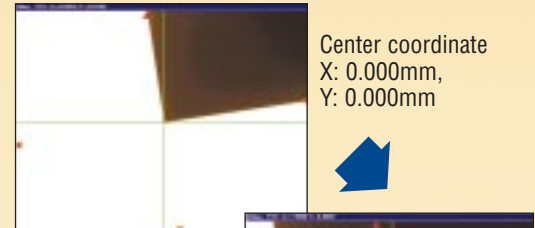

Even though the workpiece is not placed in parallel with the machine coordinate system, after setting the workpiece coordinate system, the stage can be moved along the workpiece coordinate system.

Repeat measurement navigation (QS-E model)

The Quick Scope QS-L can repeat measurement routines (measuring commands, illumination settings, zoom lens magnification, etc.) set in the Learn mode.

The distance from the current position (green cross-hairs at the center) to the next target point (red cross-hairs) are indicated by the counter above the screen. When moving to the next measurement point, all the operator has to do is move the X,Y table until either the counter reads zero or by laying the green cross-hairs on top of the red cross-hairs.

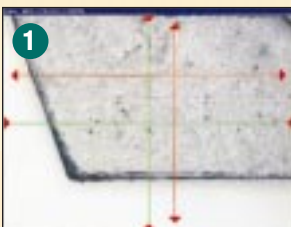

Start repeat-mode.



Move the stage to place the green cross-hairs on top of the red cross-hairs.

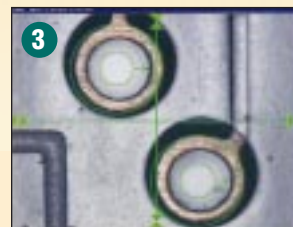

As the green cross-hairs approach the red cross-hairs the next measurement point comes into the screen.

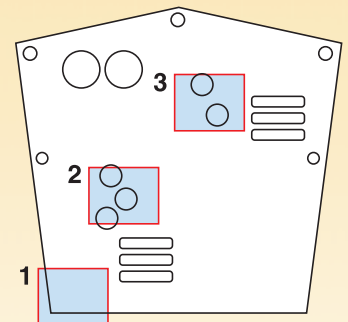

Dimensions/Specifications

QS200Z (Zoom type)
QS250Z (Zoom type)
QS200 (Fixed-magnification type)
QS250 (Fixed-magnification type)

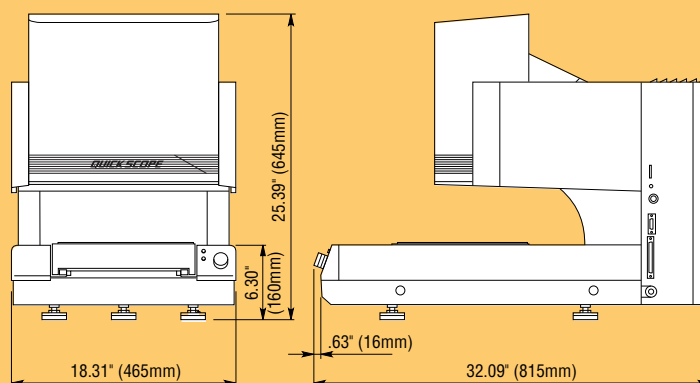

Specifications

| Model | QS200Z QS200 | QS250Z QS250 | |
|--|--|---|-------------|
| Range | <i>X-axis</i> | 8" (200mm) | 8" (200mm) |
| | <i>Y-axis</i> | 8" (200mm) | 10" (250mm) |
| | <i>Z-axis</i> | 4" (100mm) | 4" (100mm) |
| Resolution | 0.0005mm | | |
| Length standard | Reflective linear encoder | | |
| Measuring accuracy (at 20 C) | (3+10L/1000) μm | | |
| Machine operation | CNC/manual (motor-driven) Maximum drive speed: 50mm/s Maximum acceleration: 250mm/s ² | | |
| Auto-focus function | Provided as standard | | |
| Magnification on 17" monitor (Select either the power-zoom lens type or the fixed-magnification type.) | QS200Z/250Z: 21X - 147X (8-step zoom) QS200/250: 42X / 105X / 210X when using 1X objective (02ALA400) when using 2.5X objective (02ALA410) when using 5X objective (02ALA420) | | |
| Image detecting unit | High-resolution 1/3" color CCD camera | | |
| Illuminations | <i>Surface</i> | Co-axial light, fiber-optic ring light | |
| | <i>Contour</i> | Stage light | |
| Table glass size | 10.59" x 10.28" (269 x 261mm) | 10.59" x 12.24" (269 x 311mm) | |
| Maximum workpiece height | 4.33" (110mm) | | |
| Maximum workpiece weight | 22 lbs. (10kg) | | |
| Power supply | 100V - 240V AC | | |
| Power consumption | 1300VA at max. | | |
| Dimensions (W x D x H) | <i>Main unit</i> | 18.31" x 32.09" x 25.39" (465 x 815 x 645mm) | |
| | <i>Power unit</i> | | |
| Mass | <i>Main unit</i> | 165 lbs. (75kg) | |
| | <i>Power unit</i> | | |

*When using 2.5X objective or the zoom lens in 2.5X magnification (Magnification on monitor: 105X),
L= Measuring length (mm)

Zoom Lens Specifications for QS200Z, and QS250Z

| Lens magnification (8-step) | 0.5X | 0.65X | 0.85X | 1X | 1.5X | 2X | 2.5X | 3.5X |
|---------------------------------|--------------------------------|---------------------------------|-------------------------------|--------------------------------|--------------------------------|--------------------------------|----------------------------------|------------------------------|
| Magnification on monitor | 21X | 27X | 36X | 42X | 63X | 84X | 105X | 147X |
| View fields | .378" x .283" (9.6 x 7.2mm) | .294" x .22" (7.47 x 5.6mm.) | .22" x .165" (5.6 x 4.2mm) | .189" x .142" (4.8 x 3.6mm) | .126" x .094" (3.2 x 2.4mm) | .094" x .071" (2.4 x 1.8mm) | .076" x .057" (1.92 x 1.44mm) | .055" x .039" (1.4 x 1mm) |
| Working distance | 2.17" (55mm) | | | | | | | |

QS-E1020

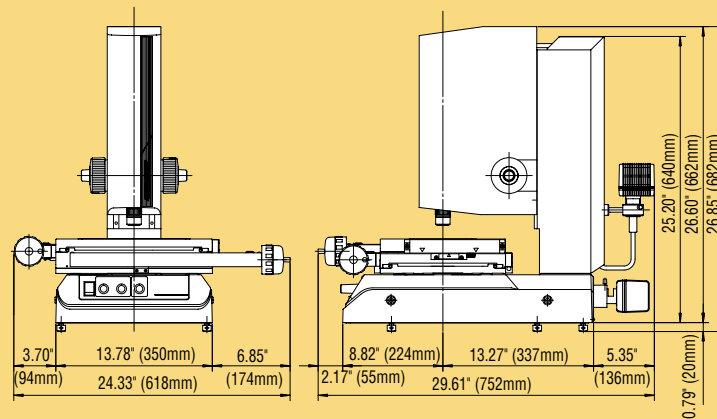

Specifications

| Model | | QS-E1020 |
|------------------------------|----------------|---|
| Range | <i>X-axis</i> | 8" (200mm) |
| | <i>Y-axis</i> | 4" (100mm) |
| | <i>Z-axis</i> | 6" (150mm) |
| Resolution | | 0.0001mm |
| Length standard | | Reflective linear encoder |
| Measuring accuracy (at 20 C) | | (3+20L/1000) m |
| Machine operation | | Manual |
| Auto-focus function | | Not available |
| Magnification on 17" monitor | | 42X / 105X / 210X when using 1X objective (02ALA400) when using 2.5X objective (02ALA410) when using 5X objective (02ALA420) |
| Image detecting unit | | High-resolution 1/3" color CCD camera |
| Illuminations | <i>Surface</i> | Co-axial light |
| | <i>Contour</i> | Stage light |
| Table glass size | | 9.44" x 5.51" (240 x 140mm) |
| Maximum workpiece height | | 5.50" (150mm) |
| Maximum workpiece weight | | 22 lbs. (10kg) |
| Power supply | | 100-120V/220-240V AC 10% |
| Power consumption | | 160VA at max. |
| Dimensions (W x D x H) | | 24.33" x 29.60" x 26.85" (618 x 752 x 682mm) |
| Mass | | 126 lbs. (57kg) |

Optional Accessories

- 960945 Machine table
- 02AKN020 Calibration glass chart
- 02ALA400 Objective 1X*
- 02ALA410 Objective 2.5X*
- 02ALA420 Objective 5X*

Calibration glass chart



| Order No. | 02ALA400 | 02ALA410 | 02ALA420 |
|--------------------------|-------------|---------------|---------------|
| Magnification | 1X | 2.5X | 5.0X |
| Magnification on monitor | 42X | 105X | 210X |
| View field | 4.8 x 3.6mm | 1.92 x 1.44mm | 0.96 x 0.72mm |
| Working distance | 34mm | 34mm | 33.5mm |

*Can not be used for the power zoom type Quick Scope.

- 02APA900 Control box for QS CNC
- 960707 Joystick box for QS CNC
- 937179T Foot switch
- 12AAA645 Color filter (GIF) for QS-E
- 12AAA646 Color filter (LB80) for QS-E
- 12AAA643 Color filter (ND2) for QS-E
- 12AAA644 Color filter (ND8) for QS-E
- 359-643 Fiber-optic ring light unit for QS-E

(Suffix code according to AC line voltage: C for 110V AC, A for 120V AC, D for 120V AC, E for 240V AC, no suffix for 100V AC)

- 172-289 Rotary table 200mm
- 999678 T-groove mount adapter
- 172-197 Swivel center support**
- 172-196 Rotary table 100mm**
- 176-107 Holder with clamp**
- 172-378 V-block**

**Can be used with T-groove mount adapter (999678) for QS-E.

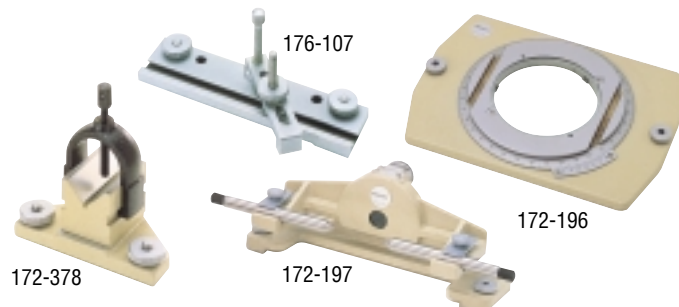

System Diagram

QS CNC Series

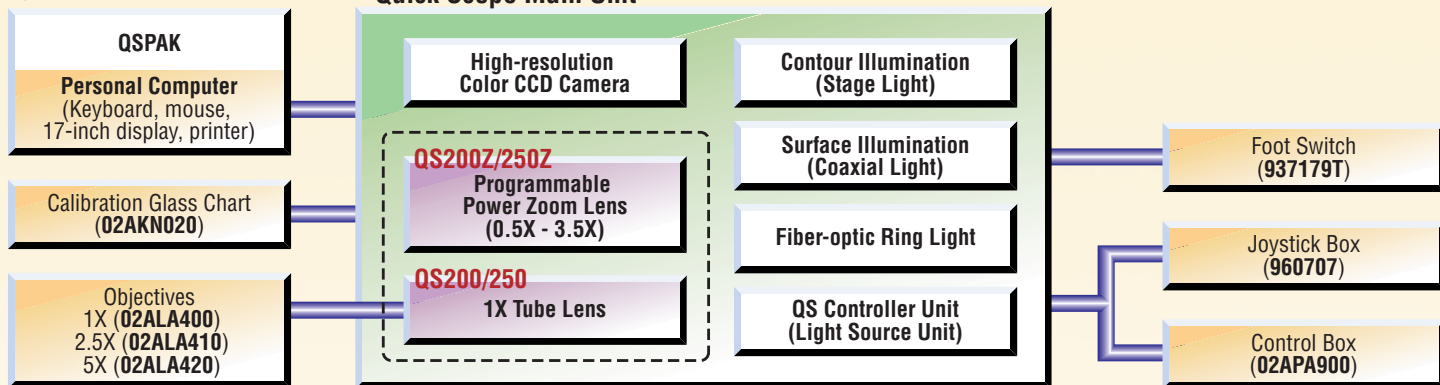

QS-E Series

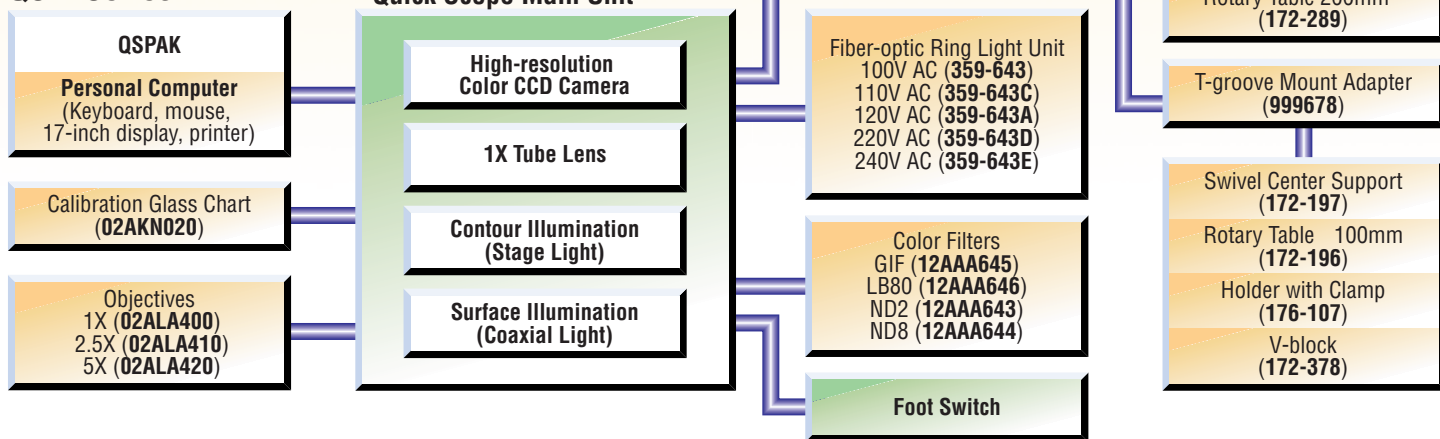

- : Standard accessory
- : Optional accessory
- : Select either when ordering



Mitutoyo America Corporation

Michigan

45001 Five Mile Road
Plymouth, MI 48170
Phone: (734) 459-2810
Fax: (734) 459-0455

Illinois

965 Corporate Blvd.
Aurora, IL 60504
Phone: (630) 978-5385
Fax: (630) 820-7403

California

16925 Gale Ave.
City of Industry, CA 91745
Phone: (626) 961-9661
Fax: (626) 333-8019

Metrology/Demonstration Centers

Massachusetts

1 Park Drive
Suite 11
Westford, MA 01886
Phone: (978) 692-8765
Fax: (978) 692-9729

Indiana

9855 Crosspoint Blvd.
Suite 148
Indianapolis, IN 46256
Phone: (317) 577-6070
Fax: (317) 577-6080

North Carolina

11515 Vanstory Drive
Suite 150
Huntersville, NC 28078
Phone: (704) 875-8332
Fax: (704) 875-9273



FM33587
ISO 9001



JSAQ-052
ISO 9001