

Durotwin SERIES 963 Rockwell/Rockwell Superficial Hardness Testing Machine

Sturdy and easy-to-operate. Ideal for low volume maintenance departments and laboratories.

- Economic type
- Non-motorized oil dash pot control
- For Rockwell Hardness Scales A-D-C-F-B-G and others with optional accessories
- For Rockwell Superficial Hardness 15N-30N-45N-15T-30T and 45T
- Wide range of optional accessories

Main Features

- Simple operation
- Compact and sturdy structure
- Automatic zero device
- Minimum resolution:
Rockwell 0.5HR
Rockwell Superficial 1 HR
- Preliminary test force:
Rockwell 10kgf
Rockwell Superficial 3kgf
- Test loads: 15, 30, 45, 60, 100 and 150kgf
- For flat specimens or cylindrical with optional accessories
- Large specimens (optional table)



Specifications

Model	DT-10	
Order No.	963-102R	
Scale selection	By manual substitution of test loads	
Reading	Analog	
Specimen height	With plain anvil	105mm (with spindle cover) 170mm (with spindle cover)
	With \varnothing 200mm table	170mm
Specimen height	155mm (from the center of indenter shaft)	
Load time	Manual	
Approx.	44kg	

Standard Accessories

Diamond indenter (1pc.)
Spherical indenter \varnothing 1/16" (1pc.)
Spare steel balls \varnothing 1/16" (5pcs.)
Level (1pc.)
Plain anvil \varnothing 63mm (1pc.)
"V" anvil 25x \varnothing 41mm (1pc.)
Hardness test block 60HRC (1pc.)*
Hardness test block 60HR30N (1pc.)*
Accessory case (1pc.)
User's manual (1pc.)
Vinyl cover (1pc.)

*Nominal values



NEW Product News

Dimensions

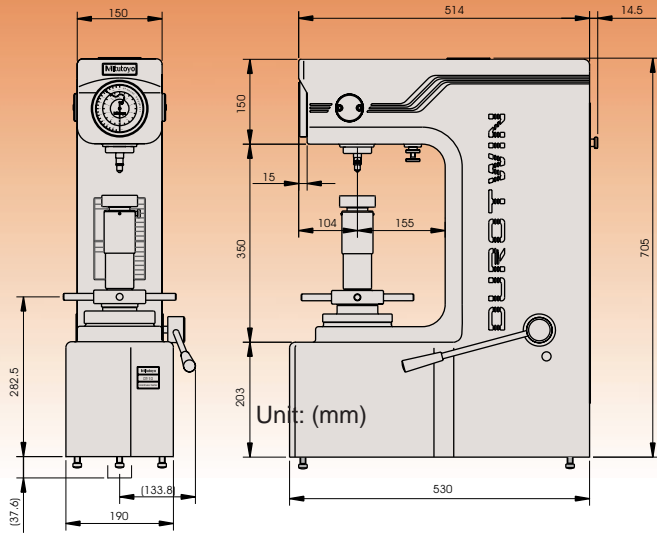

Optional Accessories

For Rockwell/Rockwell Superficial Type Hardness Testing machines

Round table



Diameter: 8" (203mm)
810-037-7

Spot anvil



Diameter: .25" (6.4mm)
Height: .88" (22mm)
810-044-7

V-anvils

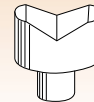

Diameter: 3.5" (89mm)
Groove width: 3.5" (89mm)
810-040-7

Rockwell Type Diamond Indenters

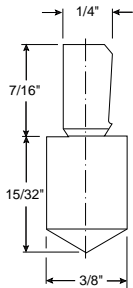

Order No.	Scale
64BAA072	C
64BAA073	N
64BAA086	A

Steel Ball Indenters

Order No.	Description
64BAA074	1/16" diameter steel ball indenter
64BAA075	1/8" diameter steel ball indenter
64BAA076	1/4" diameter steel ball indenter
64BAA077	1/2" diameter steel ball indenter
64BAA082	1/16" diameter spare steel ball (10 pcs)
64BAA083	1/8" diameter spare steel ball (10 pcs)
64BAA084	1/4" diameter spare steel ball (10 pcs)
64BAA085	1/2" diameter spare steel ball (10 pcs)



Calibration Set

Order No. 64BAA241 C Scale Set	Order No. 64BAA242 B Scale Set	Order No. 64BAA243 30N Scale Set	Order No. 64BAA244 30T Scale Set
Includes: <u>Test Blocks</u> 64BAA125 64BAA124 64BAA158 <u>Indenter</u> 64BAA072	Includes: <u>Test Blocks</u> 64BAA126 64BAA132 64BAA135 <u>Indenter</u> 64BAA078	Includes: <u>Test Blocks</u> 64BAA128 64BAA165 64BAA167 <u>Indenter</u> 64BAA073	Includes: <u>Test Blocks</u> 64BAA129 64BAA140 64BAA130 <u>Indenter</u> 64BAA078

Distributed By:

Mitutoyo
www.mitutoyo.com

Mitutoyo America Corporation

New Jersey
18 Essex Road
Paramus, NJ 07652
Phone: (201) 368-0525
Fax: 201-343-4969

Michigan
45001 Five Mile Road
Plymouth, MI 48170
Phone: (734) 459-2810
Fax: 734-459-0455

Illinois
965 Corporate Blvd.
Aurora, IL 60504
Phone: (630) 978-5385
Fax: 630-820-7403

California
16925 Gale Ave.
City of Industry, CA 91745
Phone: (626) 961-9661
Fax: 626-333-8019