

ABSOLUTE Digimatic Indicator ID-C

SERIES 543 — with Green/Red LED and GO/NG Signal Output Function



FEATURES

- With the max./min. value holding function, the signal ID-C can output the signal of the GO/±NG judgment result against the peak values set. Substitute for the mechanical/electrical contact, the judgment is carried out by calculating the measurement data obtained. This provides high reliability with no deterioration of the contact point and volume adjustment.
- The signal can be output to an external device like a sequencer through the NPN open-collector.
- The GO/±NG judgment result is also indicated by the green/red LED and the "<, O, >" signs on LCD.
- Employing the ABSOLUTE linear encoder, the Signal ID-C always displays the spindle "Absolute Position" from the origin at power-on.
- The Signal ID-C achieves the IP54 protection level to resist dust and contaminants for safe operation in harsh machine shop environments.



543-282

SPECIFICATIONS

Inch/Metric Stem dia. 3/8" #4-48 UNF Thread □ ISO/JIS type □ ANSI/AGD type

Resolution	Range	Order No. (w/ lug, flat-back)	Model	Accuracy	Measuring force
.00005"/0.001mm	.5" / 12.7mm	543-282 543-282B	ID-C112JE	.00012"	2.0N or less
.0005"/0.01mm	.5" / 12.7mm	543-283 543-283B	ID-C112JT	.00012"	2.0N or less

Inch/Metric Stem ø 8mm, M2.5 x 0.45 Thread

Resolution	Range	Order No. (w/ lug, flat-back)	Model	Accuracy	Measuring force
.00005"/0.001mm	.5" / 12.7mm	543-281 543-281B	ID-C112JM	.00012"	2.0N or less

Metric Stem ø 8mm, M2. x 0.45 Thread

Resolution	Range	Order No. (w/ lug, flat-back)	Model	Accuracy	Measuring force
0.001mm	12.7mm	543-280 543-280B	ID-C112J	0.003mm	2.0N or less

DIMENSIONS

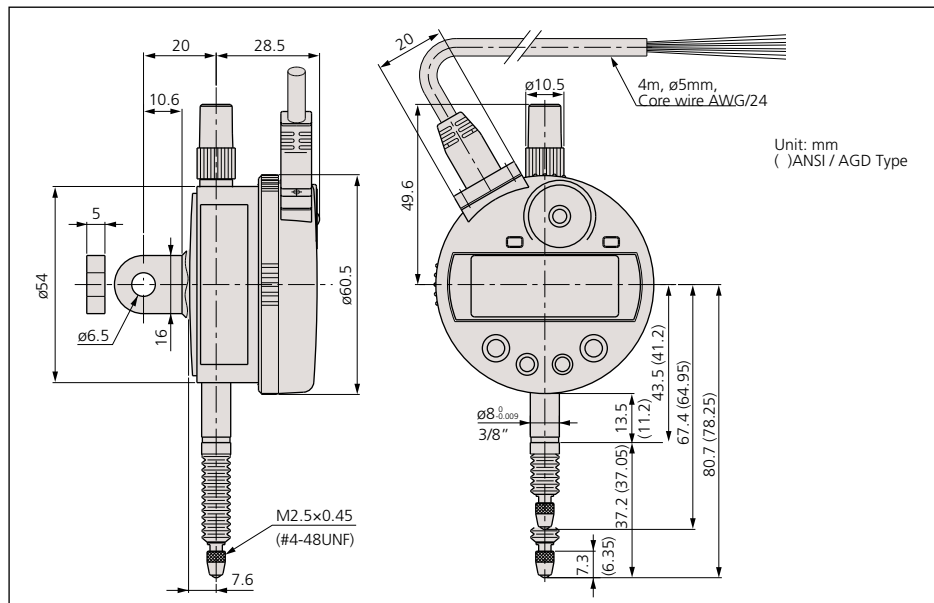

Technical Data

Accuracy: Refer to the list of specifications
 Resolution: 0.001mm, .00005"/0.001mm or .0001"/0.001mm
 Display: LCD
 Length standard: ABSOLUTE electrostatic capacitance type linear encoder
 Max. response speed: Unlimited
 Measuring force: 2.0N or less
 Power supply: DC 12 - 24V±10%
 Dust/Water protection level: IP54

Function

Data output (-NG/OK/NG signal, NPN open collector), Remote control (hold-preset, preset-recall, zero-set), Origin-set/Preset, Zero-set, GO/±NG judgment, Max/Min/Runout value holding, Counting direction switching, Power ON/OFF, inch/mm conversion (on inch/metric models only)
 Alarm: Low voltage, Counting value composition error, Over-flow error, Tolerance limit setting error

Optional Accessories

- 902011:** Spindle lifting lever* (ISO/JIS type)
- 902794:** Spindle lifting lever* (ANSI/AGD type)
- 540774:** Spindle lifting cable* (Stroke: .4" / 10mm)
- 125317:** Rubber boot
- Backs (See page F-33.)
- Contact points (See page F-34.)

*When using the spindle lifting lever/cable, IP54 is not guaranteed.

Output pattern

Wire	- NG	OK	+ NG	Composition error
Orange (- NG)	Low	High	High	High
Green (OK)	High	Low	High	High
Brown (+ NG)	High	High	Low	High
LED	Red	Green	Red	Red (blinking)
LCD	<	O	>	"x.xx" indication

I/O Specifications

Wire	Signal	I/O	Description
Black	- V (GND)	—	Connected to minus (-) terminal
Red	+ V (GND)	I	Power supply (12 - 24VDC)
Orange	- NG	O	Tolerance judgment result output: Only the terminal corresponding to a judgment result is set to the below level.
Green	OK	O	
Brown	+ NG	O	
Yellow	PRESET_RECALL ZERO	I	External input terminal: If the relevant terminal is set to the low level, its signal becomes true.
Blue	HOLD_RESET	I	
Shield	FG	—	Connected to GND

