

High Accuracy CNC Coordinate Measuring Machine **STRATO-Apex Series**

Bulletin No. 2132

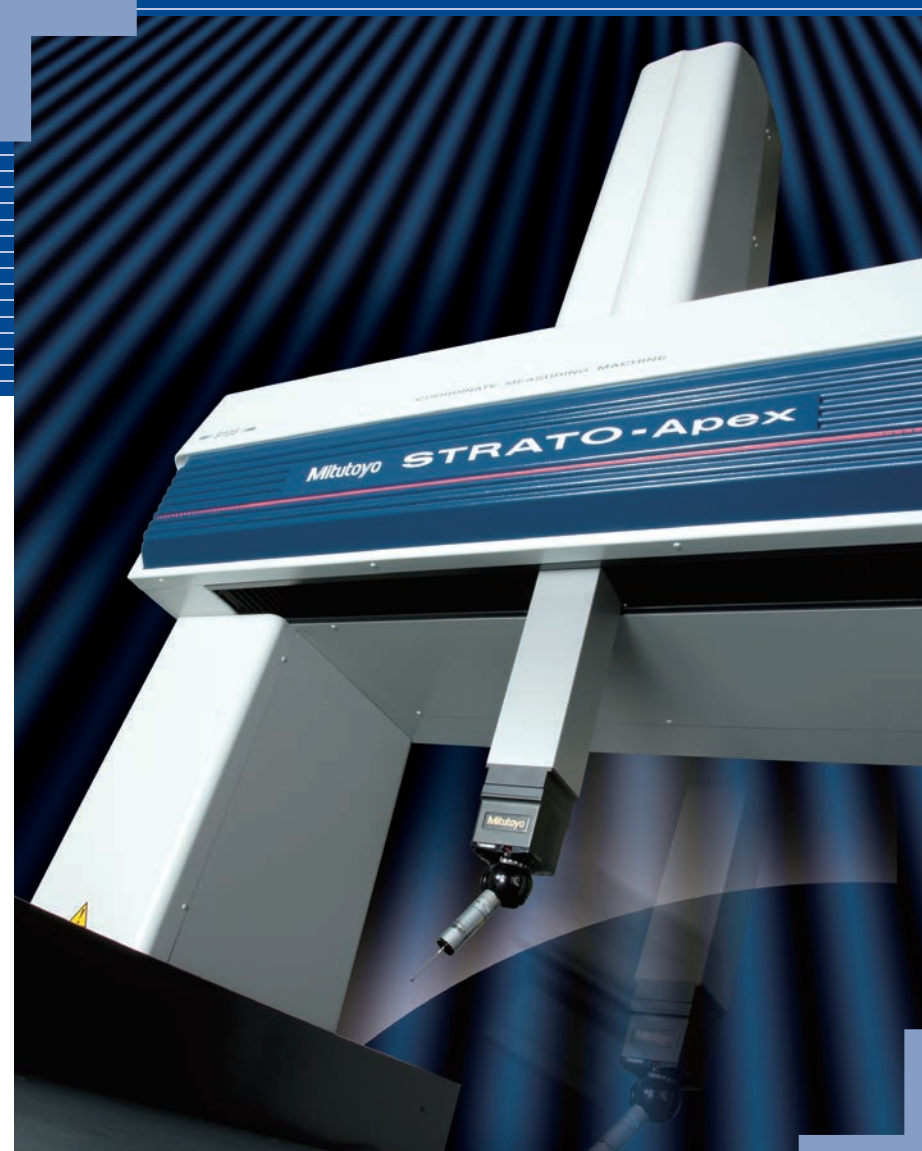

A state-of-the-art CNC Coordinate Measuring Machine that offers a rare blend of high-speed operation combined with highly accurate measurement

Mitutoyo

STRATO-Apex Series: A long-awaited, state-of-the-art CNC accuracy combined with high-speed operation

The high drive speed and acceleration guarantee top scanning performance

Improved machine rigidity

- High speed and accuracy in measurement is ensured by a redesign of the machine body that has improved rigidity of the structure, and by a remodeled guide mechanism

Newly developed, built-in, high-performance controller

- Uses a digital servo system that processes all control loops for position, speed, and current as digital signals.
- The digital servo system offers the following benefits:
 - (1) Little drift or deterioration with time
 - (2) Wide dynamic range
 - (3) Easy implementation of various types of control algorithm

Scanning measurement technology

- High-performance scanning measurement has been achieved through the improved structural rigidity and incorporation of a newly developed compensation technology
Maximum permissible scanning probe error: $MPE_{THP} = 1.8 \mu\text{m}$ (derived from scanning master ball during setup)
Maximum permissible scanning time $MPT_{\pm HP} = 45 \text{ sec}$ (to achieve $1.8 \mu\text{m}$ error)
(cf. Existing FALCIO Series: $MPE_{THP} = 2.2 \mu\text{m}$)
 $MPT_{\pm HP} = 110 \text{ sec.}$
*Probe used: SP25M



Mitutoyo

Coordinate Measuring Machine that achieves high

accuracy in a machine that also offers high-accuracy measuring in the 1 μ m class

Internal heat generation minimized

- The controller is positioned externally from the main unit to eliminate internal heat buildup.
- The compact layout design that includes the externally positioned controller while maintaining a small footprint reducing manufacturing floor space requirements.



Mitutoyo STRATO-Apex

Ultra-high precision glass scales

- Ultra-high precision crystallized glass scales with near-zero thermal expansion (Linear Coefficient of Thermal Expansion = $0.01 \times 10^{-6}/^{\circ}\text{C}$) is combined with a high-performance reflective linear encoder with a resolution of 0.02 μm to create the high accuracy measurement unit installed on each axis of the STRATO-Apex. This is basically the same measurement unit used on the ultra-high accuracy LEGEX Series CNC coordinate measuring machines.
- A unique securing method used for the scales minimizes the hysteresis error that can result from the difference in the coefficients of linear expansion between the installation plane and scale.



Vibration-dampening unit included as a standard accessory

- Floor vibrations at or near machine installation can induce measurement variations. The STRATO-Apex Series is equipped with a vibration damping unit that uses auto-leveling air springs. The vibration-dampening unit not only prevents floor vibrations from reaching the main unit, but also incorporates a function that utilizes a sensor to detect load changes caused by movements of the individual axes and placement of a workpiece and quickly restores and maintains the horizontal orientation of the main unit.

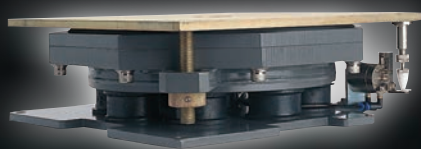

▲Vibration-dampening unit with auto-leveling air springs

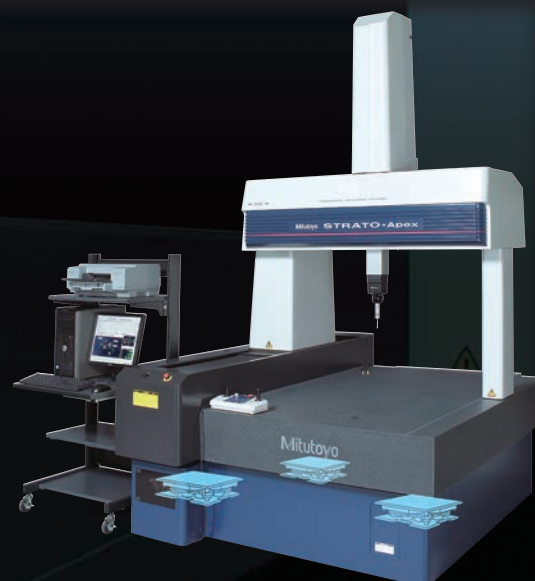

▲Vibration-dampening unit positioning

Providing the Highest Speed and Accuracy in Moving-Integration of Key Measurement Technologies



STRATO-Apex 574



STRATO-Apex 776



STRATO-Apex 9106

unit: Inch (mm)

Specifications

Item		STRATO-Apex 574	STRATO-Apex 776	STRATO-Apex 7106	STRATO-Apex 9106	STRATO-Apex 9166
Measuring range	X	19.6" (500mm)	27.5" (700mm)		35.4" (900mm)	
	Y	27.5" (700mm)	27.5" (700mm)	39.3" (1000mm)		62.9" (1600mm)
	Z	15.7" (400mm)	23.6" (600mm)			
Guide method		Air bearings on all axes (static pressure air bearings)				
Drive speed	CNC mode	Drive speed: From 8 to 300 mm/s for each axis (maximum combined speed: 519 mm/s)				
		Measuring Speed 1 – 3mm/s				
	J/S mode	Drive Speed 0 – 80mm/s				
		Measuring Speed 0 – 3mm/s				
		Fine-positioning Speed 0.05mm/s				
Drive acceleration		single axis = 1,330 mm/s ² (3 axis = 2,310mm/s ²)	1,500 mm/s ² for each axis (maximum combined acceleration: 2,598mm/s ²)			
Measuring method		Linear encoder				
Resolution		0.00005mm	0.00002mm			
Work table	Material	Granite				
	Size (table surface)	26.6" x 55.9" (676mm x 1420mm)	33.9" x 55.9" (862mm x 1420mm)	33.9" x 67.7" (862mm x 1720mm)	41.8" x 67.7" (1062mm x 1720mm)	41.8" x 91.3" (1062mm x 2320mm)
	Tapped inserts	M8 1.25mm				
Workpiece	Maximum height	22.04" (560mm)	30.31" (770mm)			
	Maximum mass	395 lbs (180kg)	1760 lbs (800kg)	2200 lbs (1000kg)	2640 lbs (1200kg)	3300 lbs (1500kg)
Machine mass (includes the vibration-dampening platform and controller, but not workpiece)		3373 lbs (1530kg)	4177 lbs (1895kg)	4806 lbs (2180kg)	5313 lbs (2410kg)	6801 lbs (3085kg)
Power supply specifications (including the probe option interface)		Power supply voltage: AC100-120/200-240 V ± 10%; power supply capacity: 700 VA (of which 170 VA is used for the probe option interface)				
Air supply	Pressure	58.0 PSI (0.4 MPa)				
	Consumption	2.1/CFM (60 L/minute) air source minimum: 4.2 (120 L/minute)				
Guaranteed accuracy temperature environment	Temperature range	64.4 – 71.6 °F (18 - 22 °C)	66.2 - 69.8 °F (19 - 21 °C)			
	Temperature change	Per hour	1.0 K			
		Per 24 hours	2.0 K			
	Temperature gradient	vertical/horizontal	1.0 K/m			

Maximum permissible error

unit: μm

Maximum permissible error	Probe used	
	TP200	SP25M
ISO 10360-2: 2009(E _{0,MPE})	1.4+2.5L/1000[500/700] 1.5+2.5L/1000[900]	0.7+2.5L/1000[500] 0.9+2.5L/1000[700/900]*

*Also applies to SP80 & MPP-310Q probe systems, SP80 & MPP-310Q not supported on 500 series

Note: This machine incorporates a main unit Startup system (relocation detection system), which disable operation when an unexpected vibration is applied or the machine is relocated. Be sure to contact your nearest Mitutoyo Sales Office prior to relocating this machine after initial installation.

Probing error

unit: μm

Maximum permissible error	Probe used	
	TP200	SP25M
ISO 10360-5:2010 (P _{FTU,MPE})	1.8μ [500/700/900]	0.7μ [500] 0.9μ [700/900]*

*Also applies to SP80 & MPP-310Q probe systems, SP80 & MPP-310Q not supported on 500 series

Scanning accuracy specification

(high-density scanning measurement using a preset route)

unit: μm

Maximum permissible error	Probe used		
	SP25M	SP80	MPP-310Q
ISO 10360-4 (s = seconds)	700 900	MPE _{THP} = 1.8μ MPT _{THP} = 45s	MPE _{THP} = 1.6μ MPT _{THP} = 70s
	500	MPE _{THP} = 1.3μ MPT _{THP} = 40s	SP80 & MPP-310Q not available on 500 series

Bridge Type Coordinate Measuring Machines

Dimensions

unit: Inch (mm)

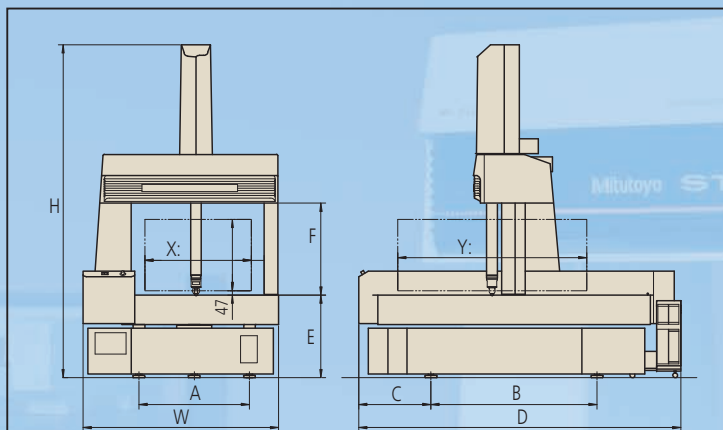

STRATO-Apex 574 Controller not as shown

STRATO- Apex					
Item	574	776	7106	9106	9166
A	24.99"(635)	29.13"(740)	37.01"(940)		
B	31.49"(800)	27.56"(700)	39.37"(1000)	55.51"(1410)	
C	16.53"(420)	21.25"(540)	24.11"(612.5)		
D	64.96"(1650)	76.38"(1940)	85.03"(2240)	108.66"(2760)	
E	29.52"(750)	27.56"(700)			
F	22.53"(572)	30.70"(780)			
W	49.99"(1270)	67.32"(1710)	75.20"(1910)		
H	94.88"(2410)	111.41"(2830)			

Installation floor space

unit: Inch (mm)

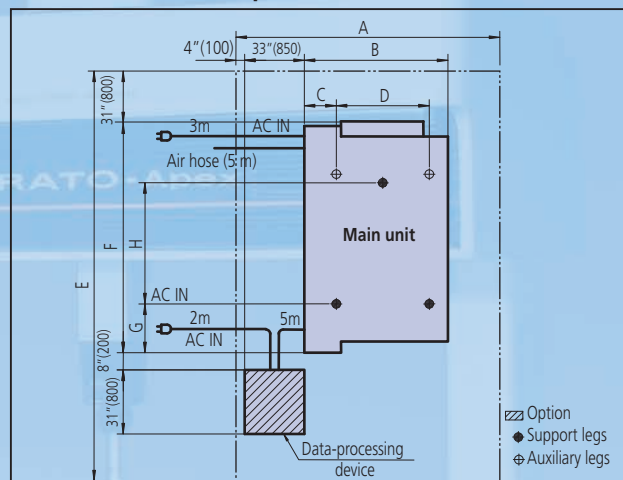

STRATO- Apex					
Item	574	776	7106	9106	9166
A	118.9" (3020)	126.5" (3210)	134.4" (3410)		
B	49.9" (1270)	57.5" (1460)	65.4" (1660)		
C	15.9" (404.5)	20.47" (520)			
D	25.0" (635)	29.13" (740)	37.01" (940)		
E	154.7" (3930)	163.9" (4160)	175.7" (4460)	199.4" (5060)	
F	64.9" (1650)	73.3" (1860)	85.1" (2160)	108.7" (2760)	
G	16.5" (420)	21.3" (540)	24.9" (632.5)		
H	31.4" (800)	27.6" (700)	39.37" (1000)	55.51" (1410)	

Tapped insert positions in the table surface

unit: mm

STRATO-Apex 574

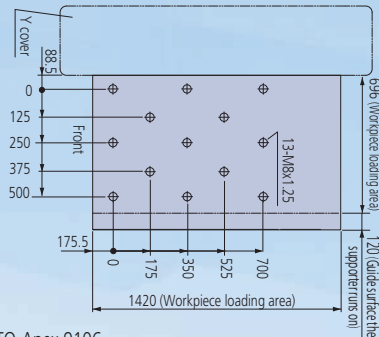

STRATO-Apex 776

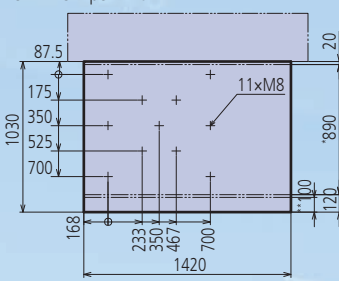

STRATO-Apex 7106

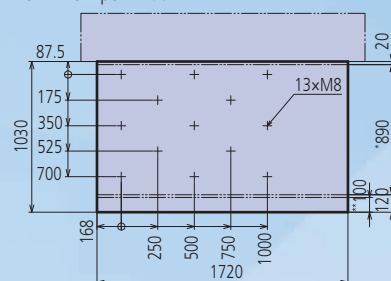

STRATO-Apex 9106

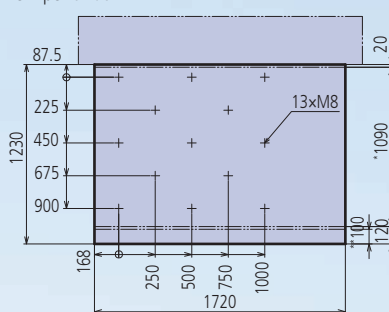

STRATO-Apex 9166

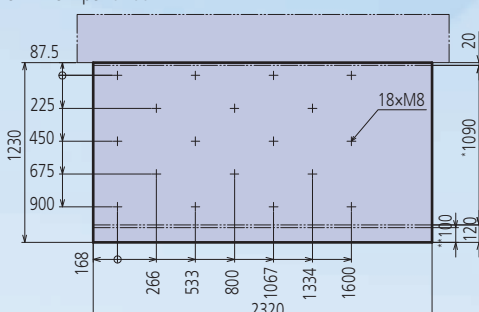

* Workpiece loading area
** Y-axis guiding surface

Software options handle all kinds of measurement



GEOPAK (High-Functionality general-purpose Measurement Program)

This module is the heart of the MCOSMOS software system and is used to measure and analyze geometric elements. All the functions are provided by icons or pull-down menus, so even novices can promptly select desired functions. Its main features include easier viewing of measuring procedures and results such as real-time graphic display of measurement results and a function for direct call-up of elements from results graphics.

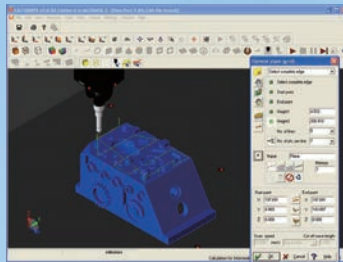

CAT1000P (Programming from a CAD Model)

This module enables the user to use CAD data and on-screen simulation to create parts programs for making automated measurements (off-line teaching). This module allows the user to begin creating a parts program as soon as the design data has been finalized, shortening the entire process.

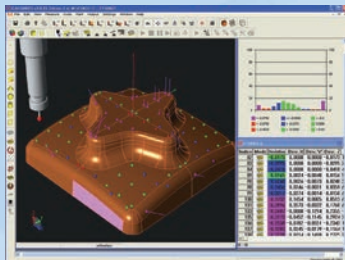

CAT1000S (Freeform Surface Evaluation Program)

Checks and compares the workpiece with the CAD data containing freeform surfaces and directly outputs the results in the form of CAD data in various formats. Software to directly convert from/to various types of CAD data is available as an option.



SurfaceMeasure606 (Non-Contact Laser Probe)

A lightweight, high-performance, non-contact probe developed for CNC coordinate measuring machines. Simplified measurement has been achieved through automatic setting of appropriate laser intensity and camera sensitivity according to environment or material, providing a simpler and more comfortable laser scanning environment.

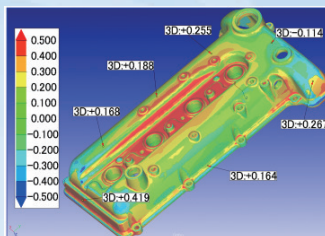

MSURF (Non-contact Laser Measurement and Evaluation Program)

MSURF-S is used for obtaining measured point cloud data with the SurfaceMeasure (non-contact laser probe), while MSURF-I is used for comparing this data with the master model data, and for making dimensional measurements. Furthermore, MSURF-G for offline teaching allows the user to create a measurement macro even without the actual workpiece, improving the measuring machine's uptime.

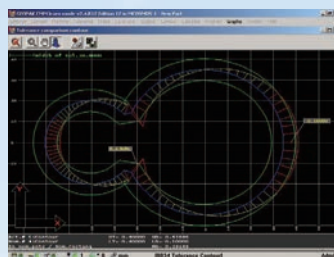

SCANPAK (Contour Measurement Program)

Software for scanning and evaluating workpiece contours (2D). Evaluates contour tolerance between measurement data and design data, and performs various types of element and inter-element calculations based on a desired range of measurement data specified by the user.

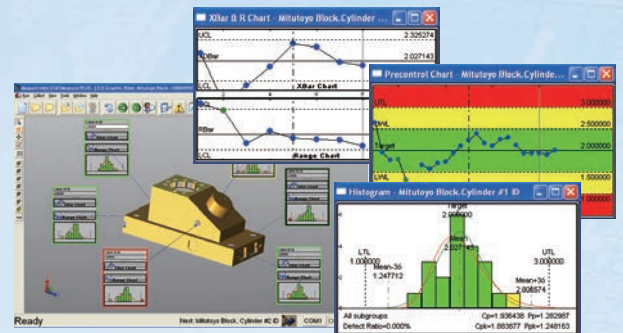

MeasurLink® STATMeasure Plus (Statistical-Processing and Process-Controlling Program)

Performs various types of statistical computations using measurement results. In addition, by displaying a control diagram on a real-time basis, this program allows defects that may occur in the future (e.g., wear or damage to cutting tools) to be discovered early on. This program can also be linked to a higher-level network environment to build a central control system.

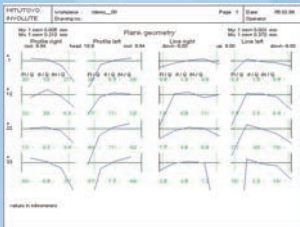

GEARPAK (Gear Evaluation Program)
For evaluating the most types of involute gears.



MPP-310Q (Scanning Probe)

A probe that collects coordinate values (point cloud data) at high accuracy by moving at speeds of up to of 120 mm/s while in contact with the workpiece. Because the MPP-310Q can also be used with the rotary table (MRT320) for synchronous scanning, it is effective for measuring gears, blades, ball screws, cylindrical cams, etc.



MRT320



CMM SurfTest Probe

Mitutoyo has developed a wide range of surface roughness analysis product line-up from hand-held portable type up to CNC type SurfTest with broader functions and higher accuracy. By utilizing the technologies developed over the years on surface roughness measuring machines, our Coordinate Measuring Machines can now execute surface roughness analysis by implementing a SurfTest Probe and the dedicated software.



SP25M (Compact high-accuracy Scanning Probe)

This is a compact, high-accuracy, multi-function scanning probe with a 25mm outside diameter that makes scanning measurements, high-accuracy point measurements, and centripetal point measurements (optional function). The SP25M is used with the PH6M, PH10M, or 10MQ auto probe head to provide a high degree of measurement freedom.



UMAP-CMM

This head makes it possible to use an ultra-small stylus (0.1- or 0.3-mm diameter). It can be installed on the PH10MQ to measure the shape and dimensions of microfabricated products from multiple directions.



NC-Auto Measure

This program generates CAD data from NC data.

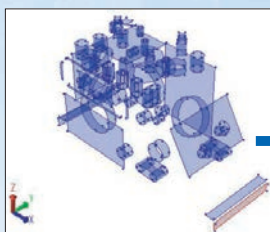

Solid Model Developer

This program generates CAD data from data measured using MCOSMOS.

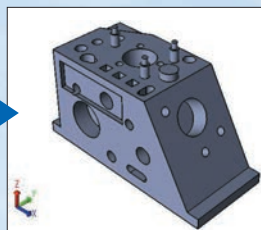

QVP (Vision Probe)

This probe automatically detects edges from image data of the workpiece magnified by a CCD camera. It is extremely useful for measuring microfabricated products that cannot be measured using a contact-type probe and soft objects that cannot be subjected to any measurement force. The QVP can also be used for measuring height based on auto-focusing.

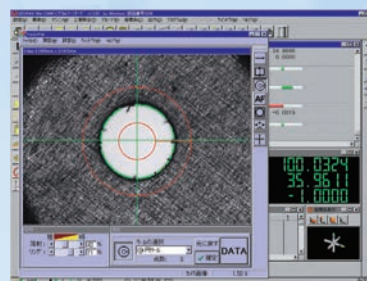

VISIONPAK (Vision Measurement Program)

This program controls QVP and performs various computational analyses on captured images

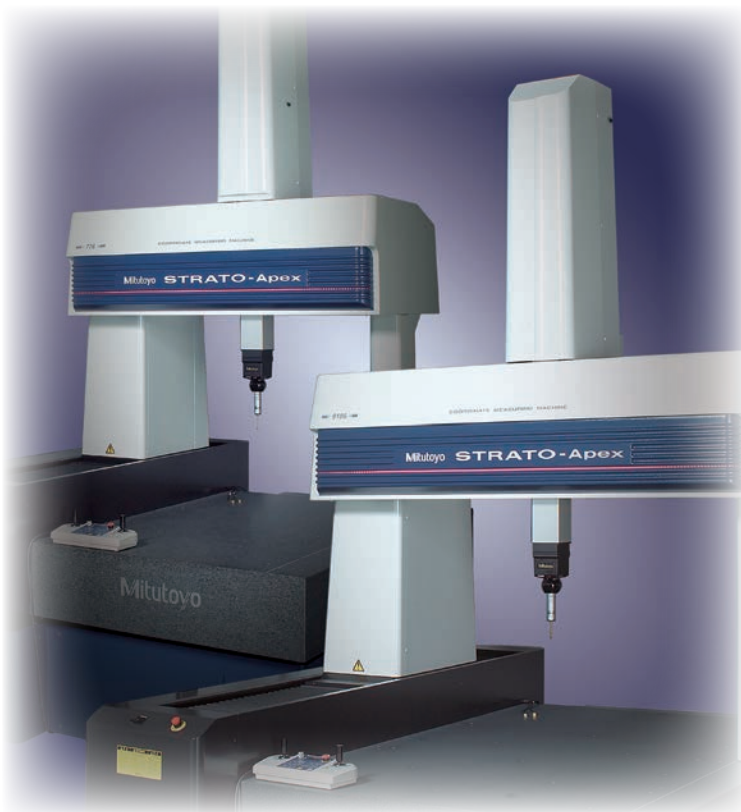

Note: All information regarding our products, and in particular the illustrations, drawings, dimensional and performance data contained in this printed matter as well as other technical data are to be regarded as approximate average values. We therefore reserve the right to make changes to the corresponding designs. The stated standards, similar technical regulations, descriptions and illustrations of the products were valid at the time of printing. In addition, the latest applicable version of our General Trading Conditions will apply. Only quotations submitted by ourselves may be regarded as definitive.

Mitutoyo products are subject to US Export Administration Regulations (EAR). Re-export or relocation of our products may require prior approval by an appropriate governing authority.

Trademarks and Registrations

Designations used by companies to distinguish their products are often claimed as trademarks. In all instances where Mitutoyo America Corporation is aware of a claim, the product names appear in initial capital or all capital letters. The appropriate companies should be contacted for more complete trademark and registration information.

- Coordinate Measuring Machines
- Vision Measuring Systems
- Form Measurement
- Optical Measuring
- Sensor Systems
- Testing Equipment and Seismometer
- Digital Scale and DRO Systems
- Small Tool Instruments and Data Management

Mitutoyo America Corporation
www.mitutoyo.com

One Number to Serve You Better
1-888-MITUTOYO (1-888-648-8869)

- M³ Solution Centers**
- Aurora, Illinois
(Corporate Headquarters)
 - Westford, Massachusetts
 - Huntersville, North Carolina
 - Mason, Ohio
 - Plymouth, Michigan
 - City of Industry, California
 - Birmingham, Alabama
 - Renton, Washington

Mitutoyo
Precision is our Profession